

REFRACTORY DIVISION CATALOGUE

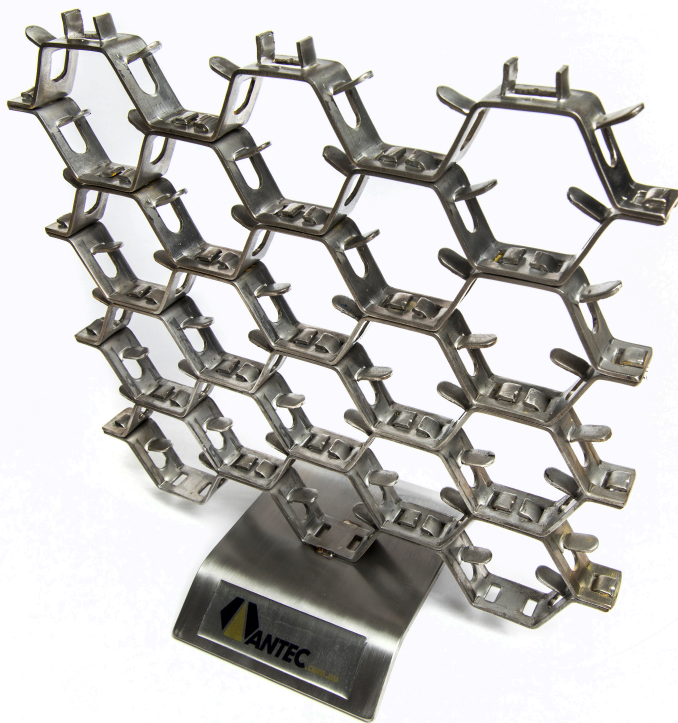



Contents

Refractory Item	Page No.
Refractory Anchors	3
Hex Mesh & Punch Tabs	87
Stainless Steel Fibres	114



Refractory Anchors

Refractory Anchors

Antec have been designing and manufacturing refractory anchors for over 25 years and offer an extensive range of high-quality standard and custom-made refractory anchor products for a variety of linings and lining depths.

Our experience has led to the development of a unique range of clever anchoring systems that offer our clients a flexible, reliable and cost-effective solution to secure refractory linings.

We offer full in-house design and manufacturing for fast turnarounds on custom anchor designs. Additionally we hold a comprehensive range of common anchor shapes and sizes in stock.

Anchor Types include:

- Y & V Anchors
- Welded & Twisted Anchors
- Split Tyne, Stud Welded and Rotalock Anchors
- Christmas Tree and Strap Anchors
- Ceramic Anchor Brick Clips
- Shelf & PV Anchors
- Shelf Brackets & Fabricated parts
- Ceramic Fibre Fixings

Material Selection

Alloys behave differently in different environments and temperatures. Therefore the choice of material is critical for the refractory anchor. Antec's experience can assist with determining the most appropriate materials for each individual application.

Antec supply anchors in a variety of material options including standard heat resisting alloys such as 304, 310 & 253 and can also supply specialist alloys such as 601 and DS in a variety of diameters.

For special requests please contact us for a custom quotation and lead time.

Anchor Spacing & Quantity Required

Anchor Spacing "P" (mm)	Anchor Quantity per m ²
150	45
175	33
200	25
225	20
250	16
300	11.5
350	8.5
450	5

Spacings given above relate to the typical anchor layouts shown below.

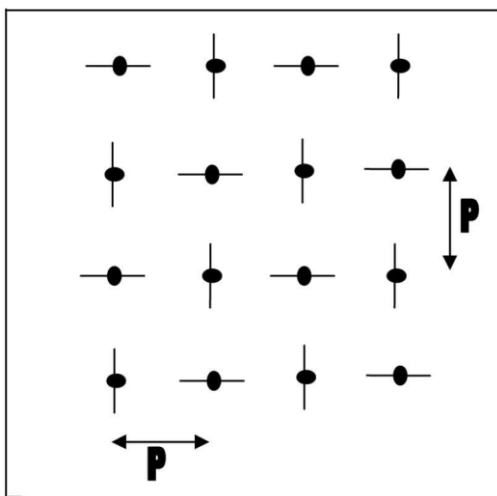

Fig. 1 – Square Pitch

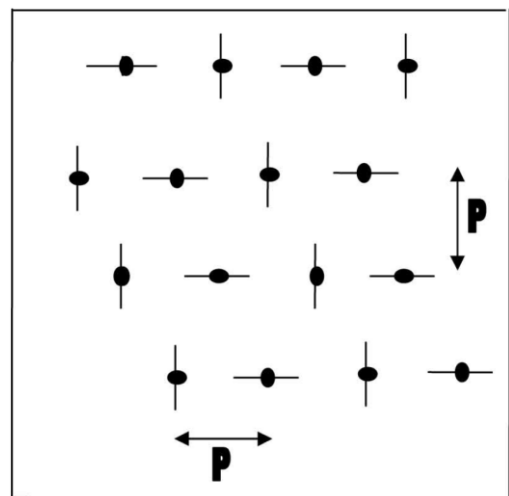
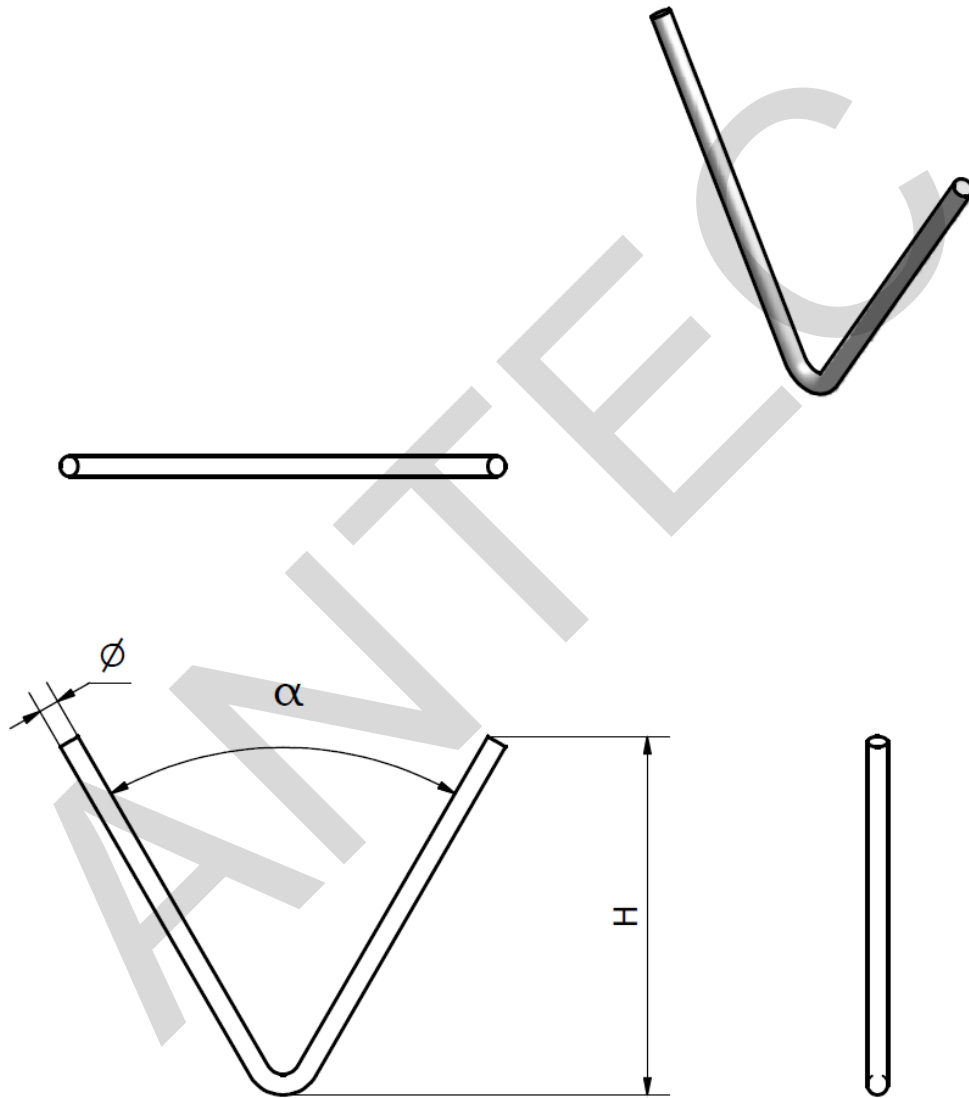

Fig. 2 – Staggered Pitch

Refractory Anchors

AN 01

V Anchor



All items can be manufactured in various alloy steels.

Tolerances:

+/- 3mm on Dimensional

+/- 3° on Angular Dimensions

Unless otherwise noted.

This drawing is the property of Antec Group Pty Ltd and is supplied on the understanding it is not to be used for any purpose, copied or communicated to any other person without written permission of the proprietor. All rights are reserved for product design concept. Antec products are guaranteed to conform within normal commercial tolerance of the applicable description furnished and to be manufactured from material as specified. No other guarantees or warranty, including warranty for fitness of products for in service operating condition shall exist in connection with sale of Antec products. Heat treatment after manufacture is not included unless specified.

Refractory Anchors

AN 02

VP Anchor

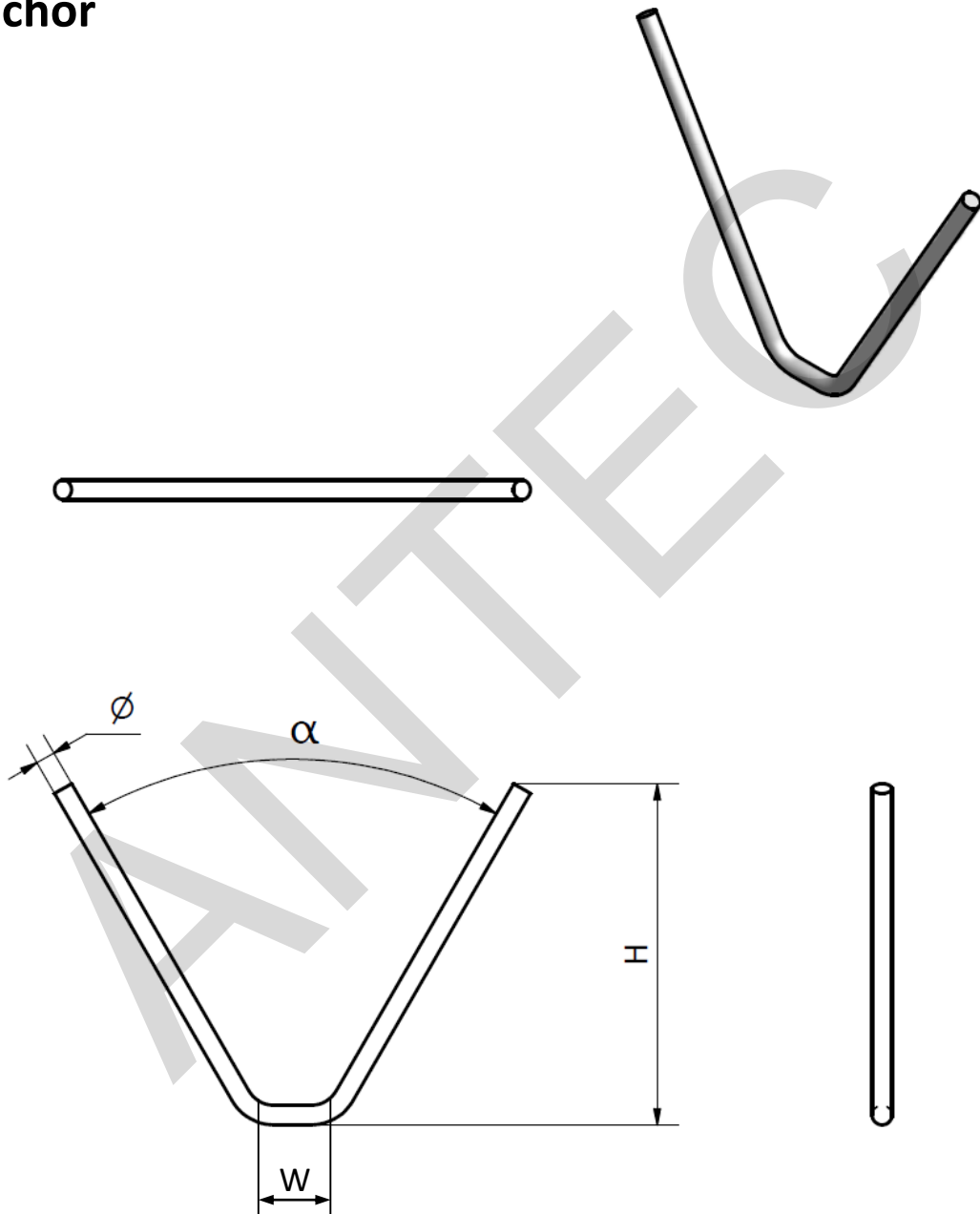

All items can be manufactured in various alloy steels.

Tolerances:

+/- 3mm on Dimensional

+/- 3° on Angular Dimensions

Unless otherwise noted.

This drawing is the property of Antec Group Pty Ltd and is supplied on the understanding it is not to be used for any purpose, copied or communicated to any other person without written permission of the proprietor. All rights are reserved for product design concept. Antec products are guaranteed to conform within normal commercial tolerance of the applicable description furnished and to be manufactured from material as specified. No other guarantees or warranty, including warranty for fitness of products for in service operating condition shall exist in connection with sale of Antec products. Heat treatment after manufacture is not included unless specified.

Refractory Anchors

AN 03

VCL Anchor

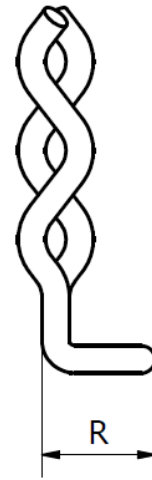
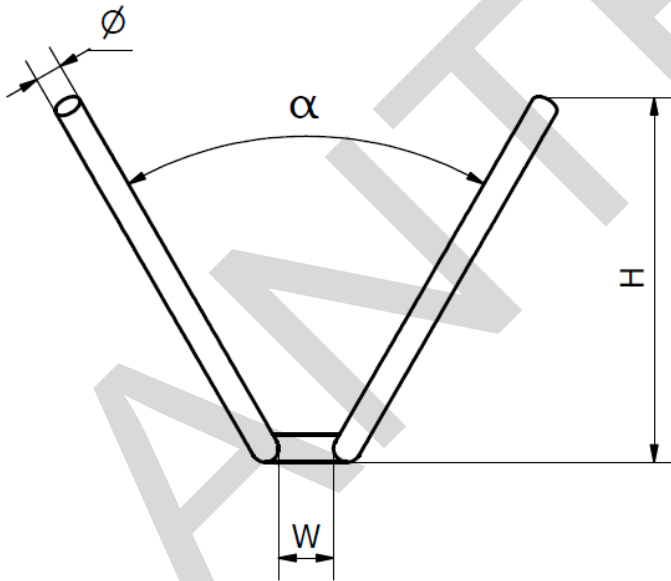
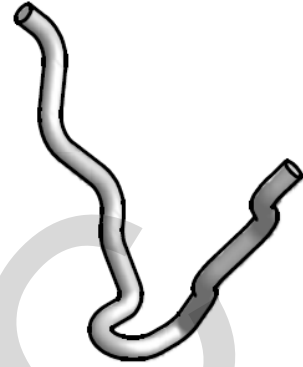
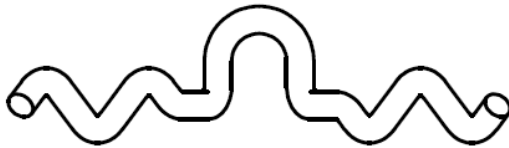

All items can be manufactured in various alloy steels.

Tolerances:

+/- 3mm on Dimensional

+/- 3° on Angular Dimensions

Unless otherwise noted

Corrugation as drawn is diagrammatic only.

STANDARD SIZES		
HEIGHT	W	ANGLE
50	12	90
65	12	60
75	12	60
80	12	60
90	12	60
100	12	60
115	12	60
125	12	60

This drawing is the property of Antec Group Pty Ltd and is supplied on the understanding it is not to be used for any purpose, copied or communicated to any other person without written permission of the proprietor. All rights are reserved for product design concept. Antec products are guaranteed to conform within normal commercial tolerance of the applicable description furnished and to be manufactured from material as specified. No other guarantees or warranty, including warranty for fitness of products for in service operating condition shall exist in connection with sale of Antec products. Heat treatment after manufacture is not included unless specified.

Refractory Anchors

AN 04

VCP Anchor

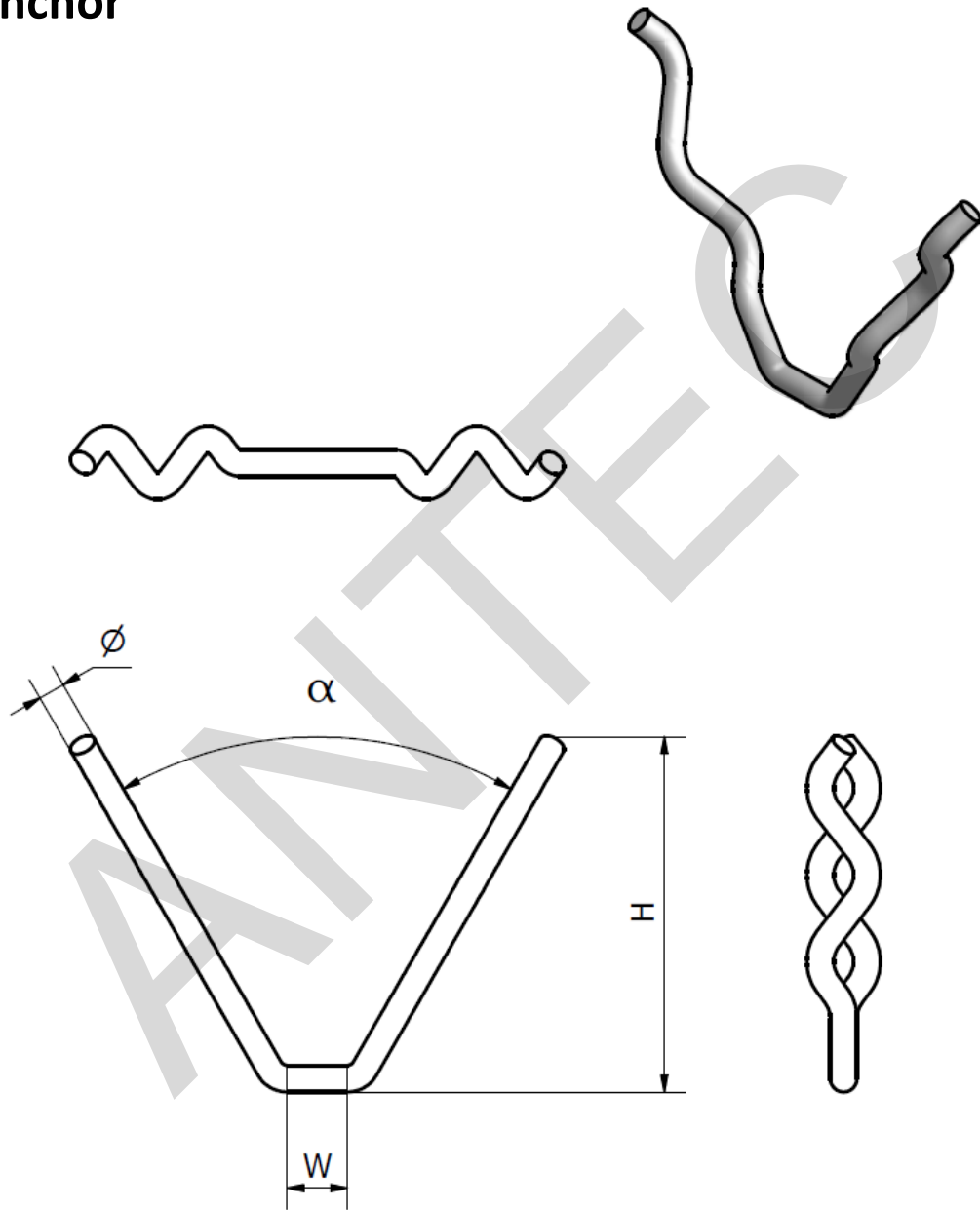

All items can be manufactured in various alloy steels.

Tolerances:

+/- 3mm on Dimensional

+/- 3° on Angular Dimensions

Unless otherwise noted

Corrugation as drawn is diagrammatic only.

This drawing is the property of Antec Group Pty Ltd and is supplied on the understanding it is not to be used for any purpose, copied or communicated to any other person without written permission of the proprietor. All rights are reserved for product design concept. Antec products are guaranteed to conform within normal commercial tolerance of the applicable description furnished and to be manufactured from material as specified. No other guarantees or warranty, including warranty for fitness of products for in service operating condition shall exist in connection with sale of Antec products. Heat treatment after manufacture is not included unless specified.

Refractory Anchors

AN 05

YCL Anchor

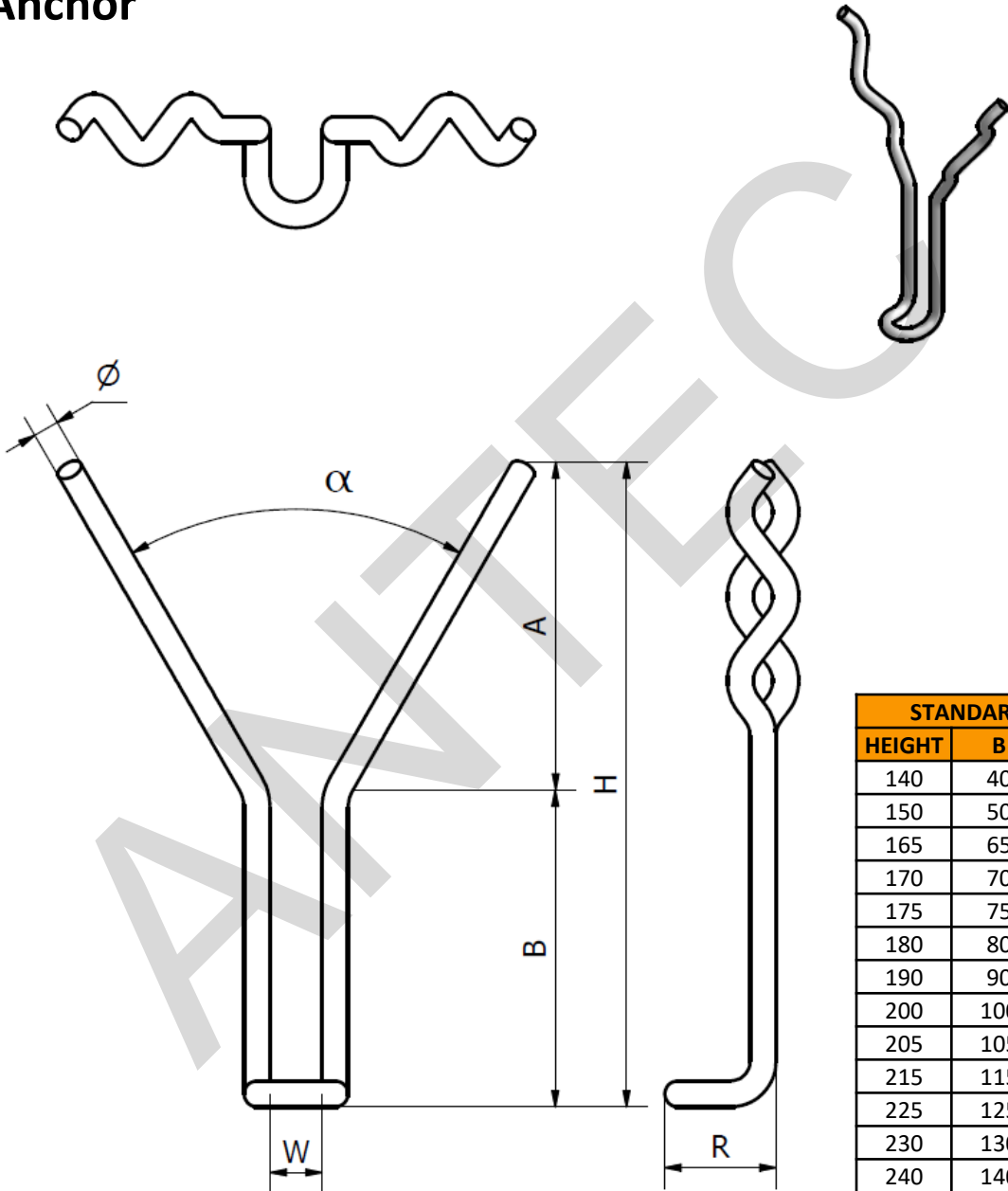

STANDARD SIZES		
HEIGHT	B	ANGLE
140	40	60
150	50	60
165	65	60
170	70	60
175	75	60
180	80	60
190	90	60
200	100	60
205	105	60
215	115	60
225	125	60
230	130	60
240	140	60
250	150	60
265	165	60
275	175	60
280	180	60
290	190	60
300	200	60
305	205	60

All items can be manufactured in various alloy steels.

Tolerances:

+/- 3mm on Dimensional

+/- 3° on Angular Dimensions

Unless otherwise noted

Corrugation as drawn is diagrammatic only.

This drawing is the property of Antec Group Pty Ltd and is supplied on the understanding it is not to be used for any purpose, copied or communicated to any other person without written permission of the proprietor. All rights are reserved for product design concept. Antec products are guaranteed to conform within normal commercial tolerance of the applicable description furnished and to be manufactured from material as specified. No other guarantees or warranty, including warranty for fitness of products for in service operating condition shall exist in connection with sale of Antec products. Heat treatment after manufacture is not included unless specified.

Refractory Anchors

AN 06

YCP Anchor

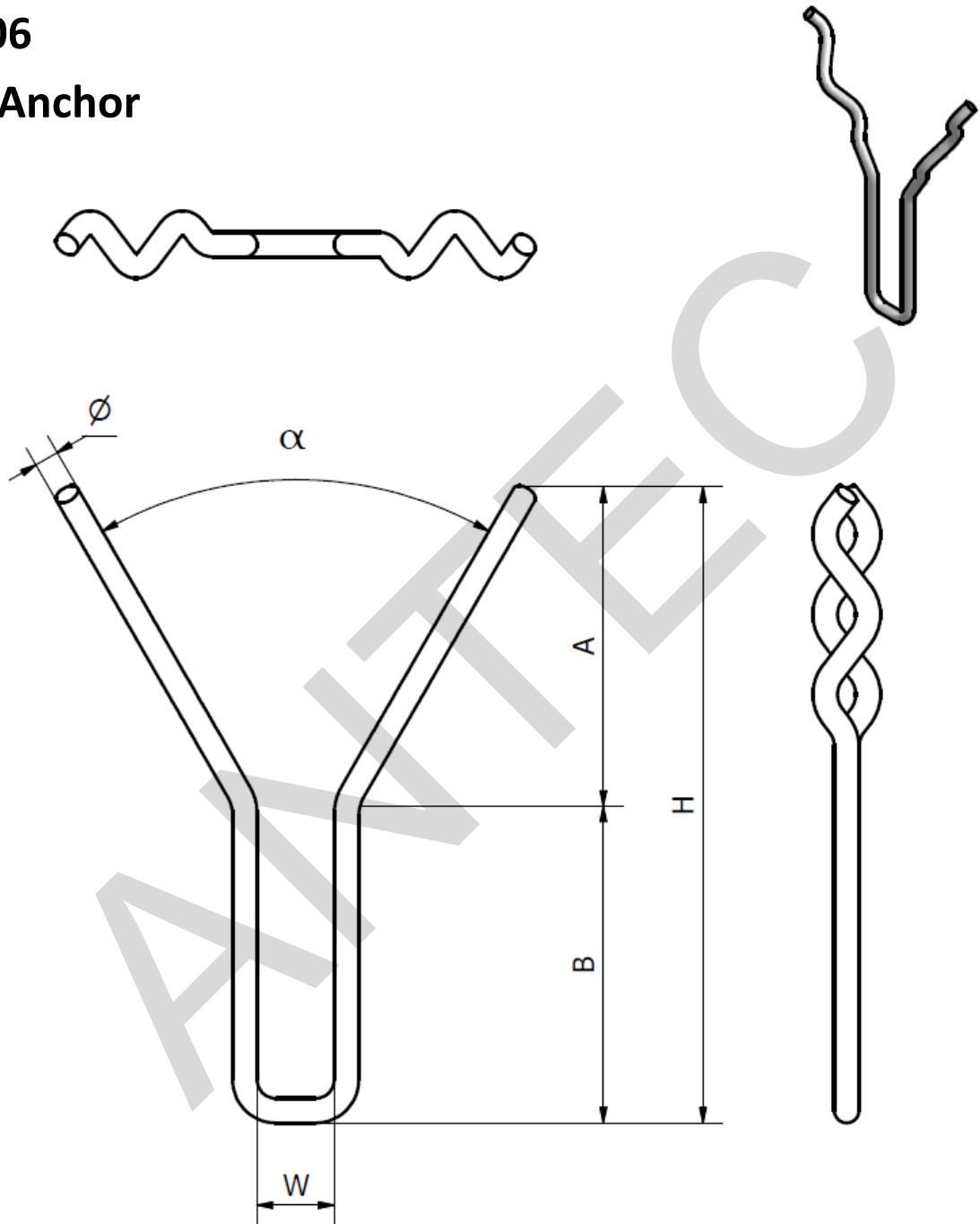

All items can be manufactured in various alloy steels.

Tolerances:

+/- 3mm on Dimensional

+/- 3° on Angular Dimensions

Unless otherwise noted

Corrugation as drawn is diagrammatic only.

This drawing is the property of Antec Group Pty Ltd and is supplied on the understanding it is not to be used for any purpose, copied or communicated to any other person without written permission of the proprietor. All rights are reserved for product design concept. Antec products are guaranteed to conform within normal commercial tolerance of the applicable description furnished and to be manufactured from material as specified. No other guarantees or warranty, including warranty for fitness of products for in service operating condition shall exist in connection with sale of Antec products. Heat treatment after manufacture is not included unless specified.

Refractory Anchors

AN 07

YP Anchor

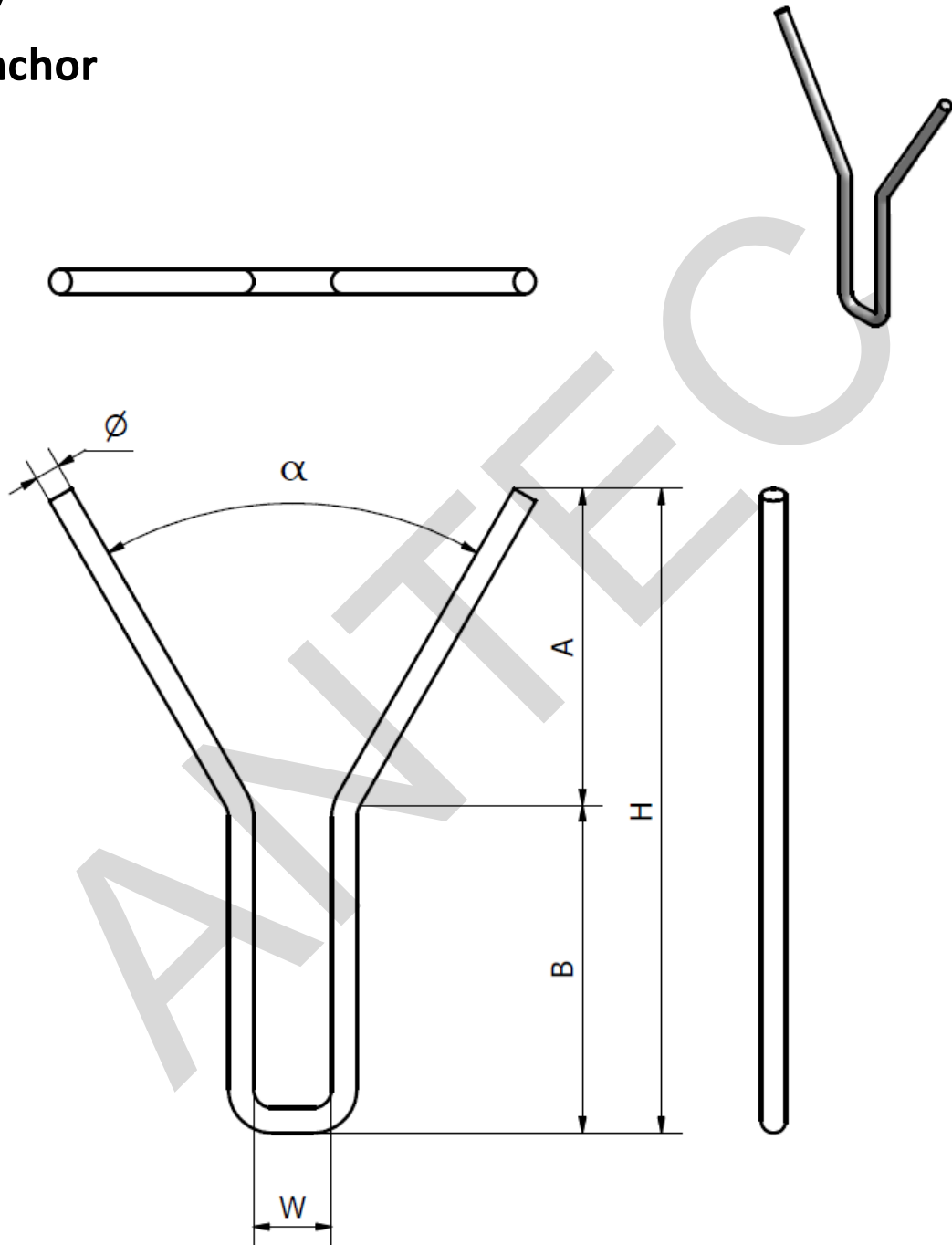

All items can be manufactured in various alloy steels.

Tolerances:

+/- 3mm on Dimensional

+/- 3° on Angular Dimensions

Unless otherwise noted.

This drawing is the property of Antec Group Pty Ltd and is supplied on the understanding it is not to be used for any purpose, copied or communicated to any other person without written permission of the proprietor. All rights are reserved for product design concept. Antec products are guaranteed to conform within normal commercial tolerance of the applicable description furnished and to be manufactured from material as specified. No other guarantees or warranty, including warranty for fitness of products for in service operating condition shall exist in connection with sale of Antec products. Heat treatment after manufacture is not included unless specified.

Refractory Anchors

AN 08

FCY Anchor

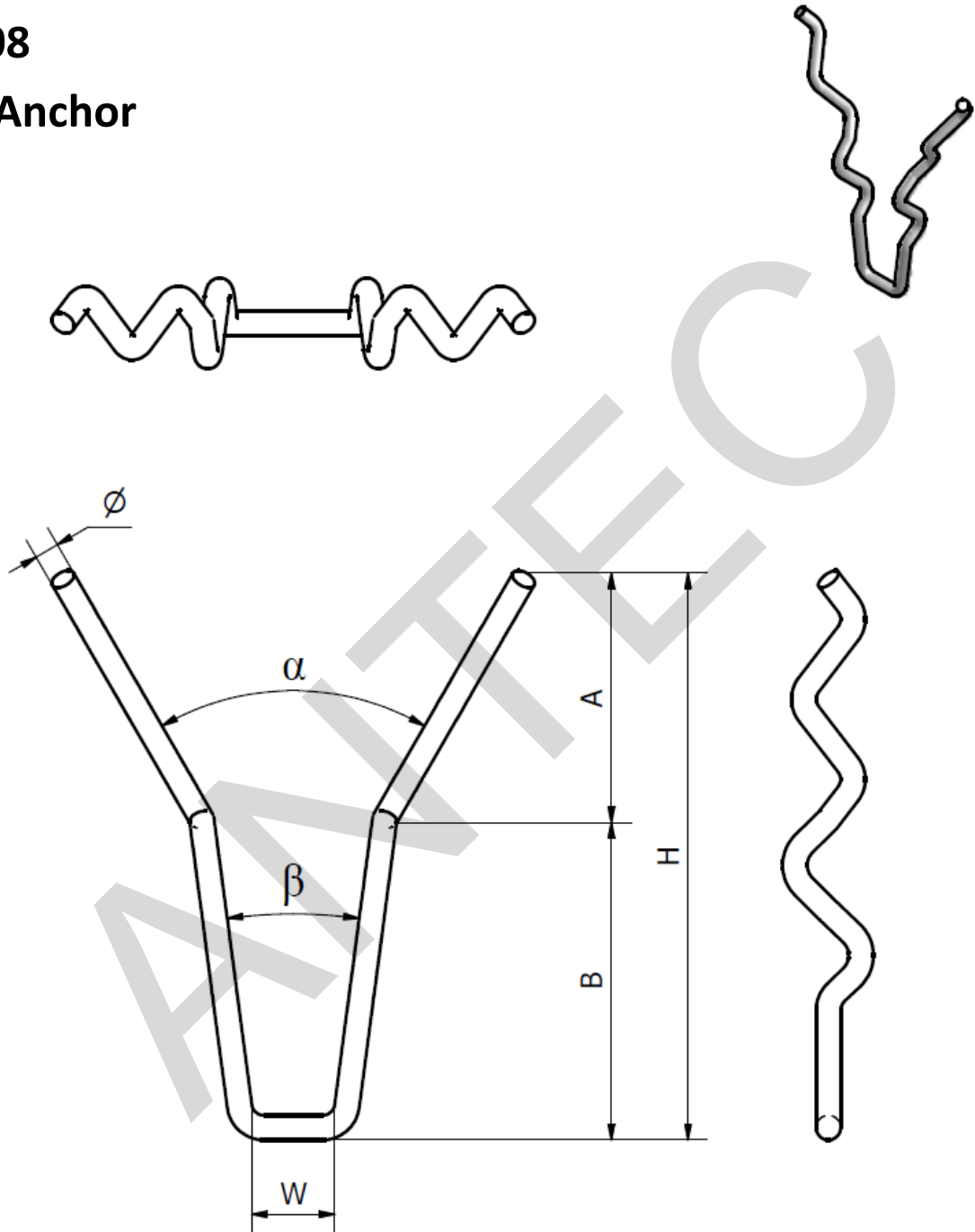

All items can be manufactured in various alloy steels.

Tolerances:

+/- 3mm on Dimensional

+/- 3° on Angular Dimensions

Unless otherwise noted

Corrugation as drawn is diagrammatic only.

This drawing is the property of Antec Group Pty Ltd and is supplied on the understanding it is not to be used for any purpose, copied or communicated to any other person without written permission of the proprietor. All rights are reserved for product design concept. Antec products are guaranteed to conform within normal commercial tolerance of the applicable description furnished and to be manufactured from material as specified. No other guarantees or warranty, including warranty for fitness of products for in service operating condition shall exist in connection with sale of Antec products. Heat treatment after manufacture is not included unless specified.

Refractory Anchors

AN 08A

FCY Anchor

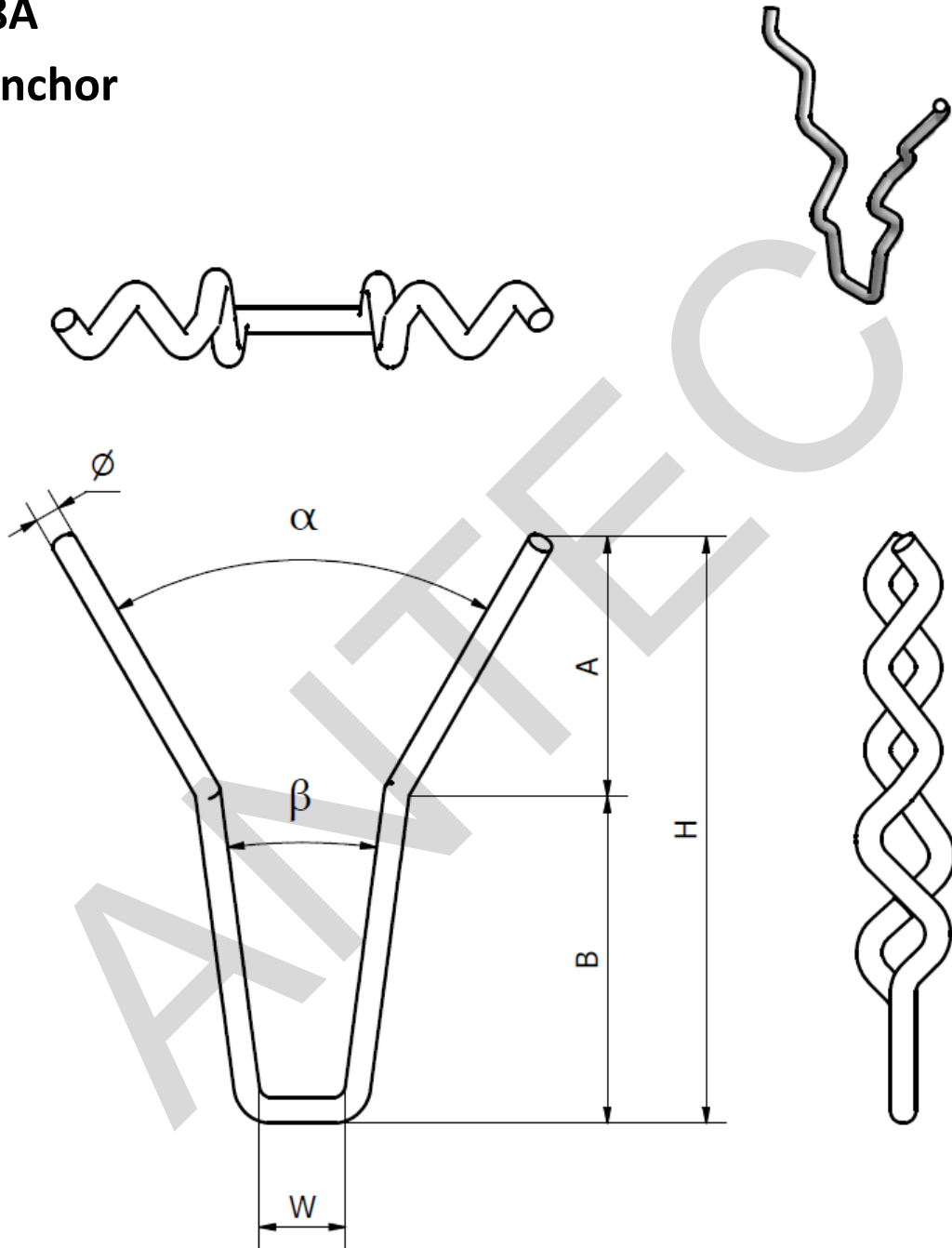

All items can be manufactured in various alloy steels.

Tolerances:

+/- 3mm on Dimensional

+/- 3° on Angular Dimensions

Unless otherwise noted

Corrugation as drawn is diagrammatic only.

This drawing is the property of Antec Group Pty Ltd and is supplied on the understanding it is not to be used for any purpose, copied or communicated to any other person without written permission of the proprietor. All rights are reserved for product design concept. Antec products are guaranteed to conform within normal commercial tolerance of the applicable description furnished and to be manufactured from material as specified. No other guarantees or warranty, including warranty for fitness of products for in service operating condition shall exist in connection with sale of Antec products. Heat treatment after manufacture is not included unless specified.

Refractory Anchors

AN 09

CH Anchor

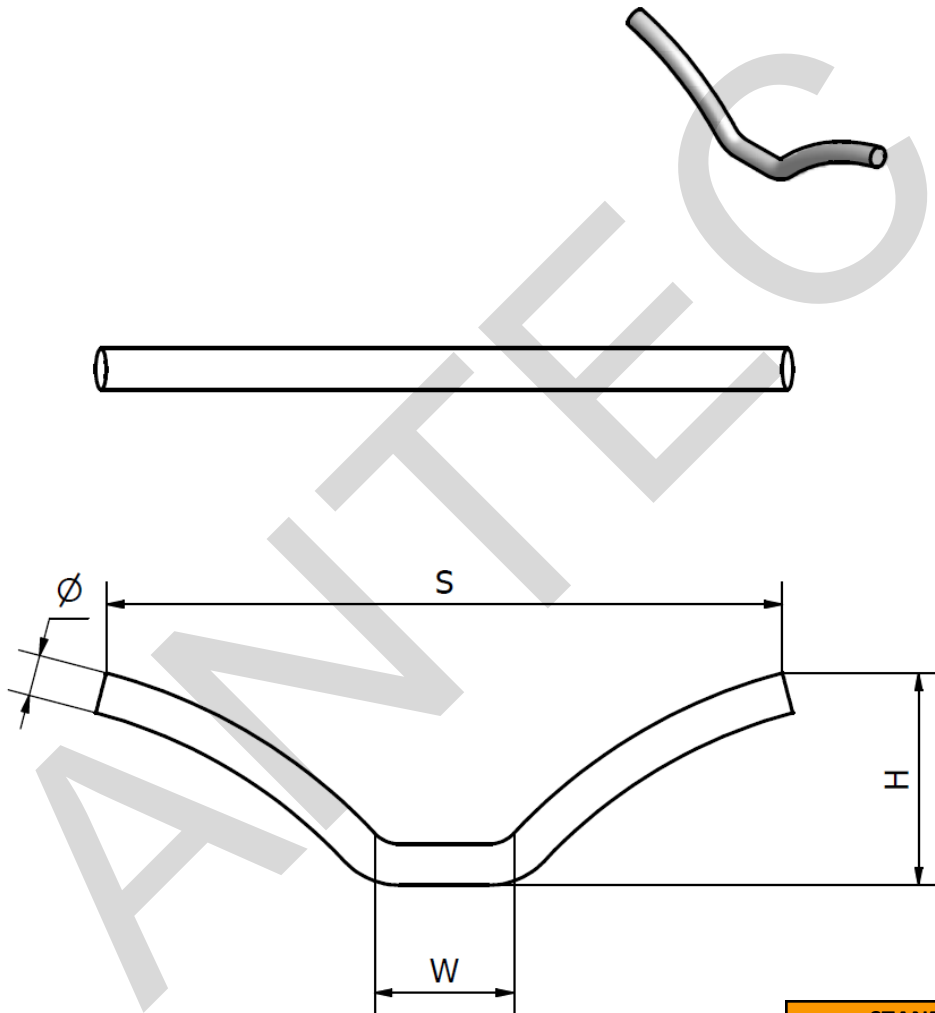

All items can be manufactured in various alloy steels.

Tolerances:

+/- 3mm on Dimensional

+/- 3° on Angular Dimensions

Unless otherwise noted.

H = 30 or above.

STANDARD SIZES				
TYPE	H	S	W	D
19 CH	19	80	15	6
25 CH	25	100	13	6
30 CH	30	125	18	6
32 CH	32	160	18	6
38 CH(A)	38	130	20	6
38 CH(B)	38	160	30	6
50 CH	50	160	30	6
65 CH	65	175	30	6
75 CH	75	170	25	6

This drawing is the property of Antec Group Pty Ltd and is supplied on the understanding it is not to be used for any purpose, copied or communicated to any other person without written permission of the proprietor. All rights are reserved for product design concept. Antec products are guaranteed to conform within normal commercial tolerance of the applicable description furnished and to be manufactured from material as specified. No other guarantees or warranty, including warranty for fitness of products for in service operating condition shall exist in connection with sale of Antec products. Heat treatment after manufacture is not included unless specified.

Refractory Anchors

AN 10

LS Anchor

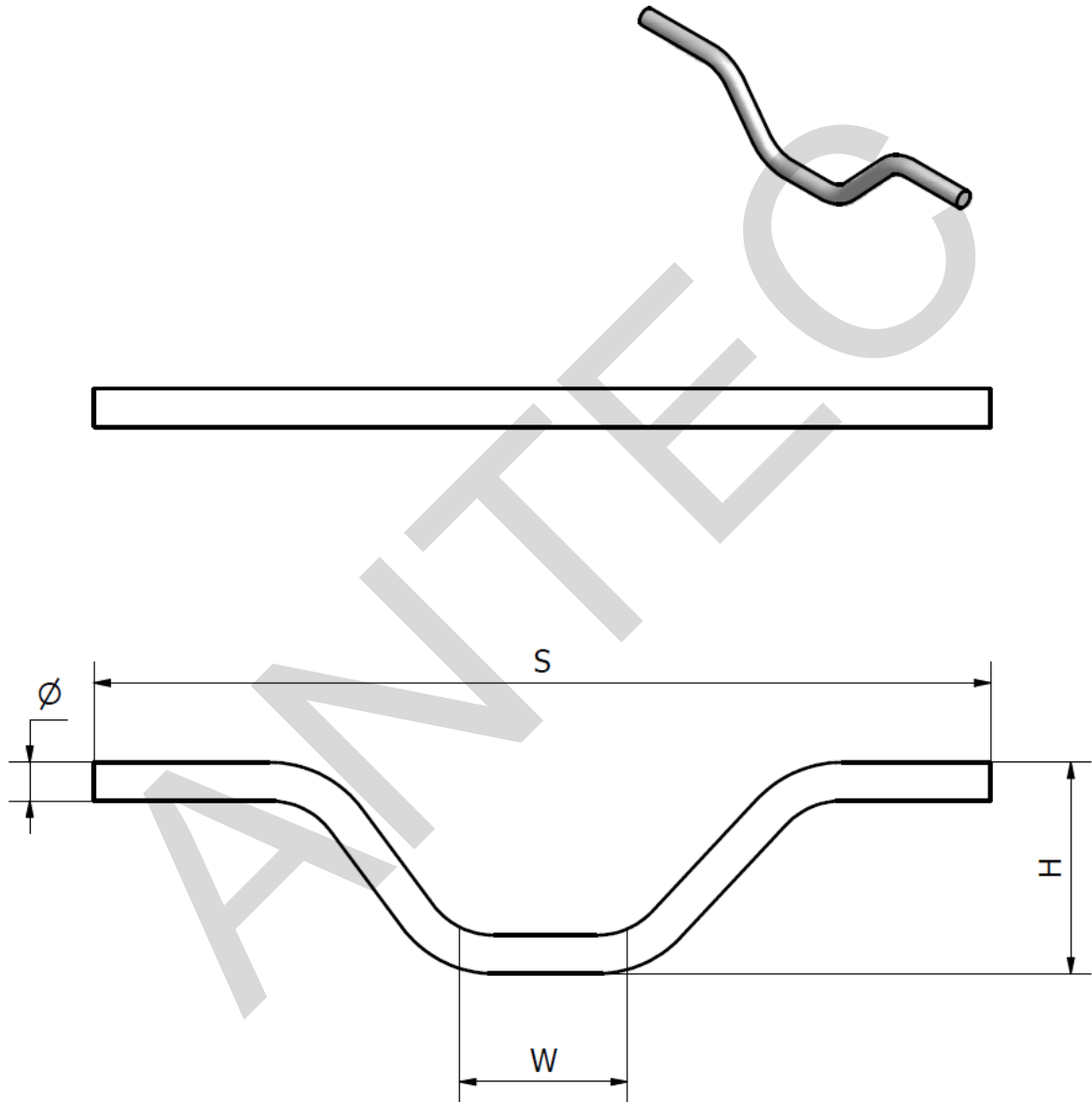

All items can be manufactured in various alloy steels.

Tolerances:

+/- 3mm on Dimensional

+/- 3° on Angular Dimensions

Unless otherwise noted.

STANDARD SIZES				
TYPE	H	S	W	D
25 LS(A)	27	140	30	6
25 LS(B)	27	175	30	6
30 LS	30	185	18	6

This drawing is the property of Antec Group Pty Ltd and is supplied on the understanding it is not to be used for any purpose, copied or communicated to any other person without written permission of the proprietor. All rights are reserved for product design concept. Antec products are guaranteed to conform within normal commercial tolerance of the applicable description furnished and to be manufactured from material as specified. No other guarantees or warranty, including warranty for fitness of products for in service operating condition shall exist in connection with sale of Antec products. Heat treatment after manufacture is not included unless specified.

Refractory Anchors

AN 11

WB Anchor

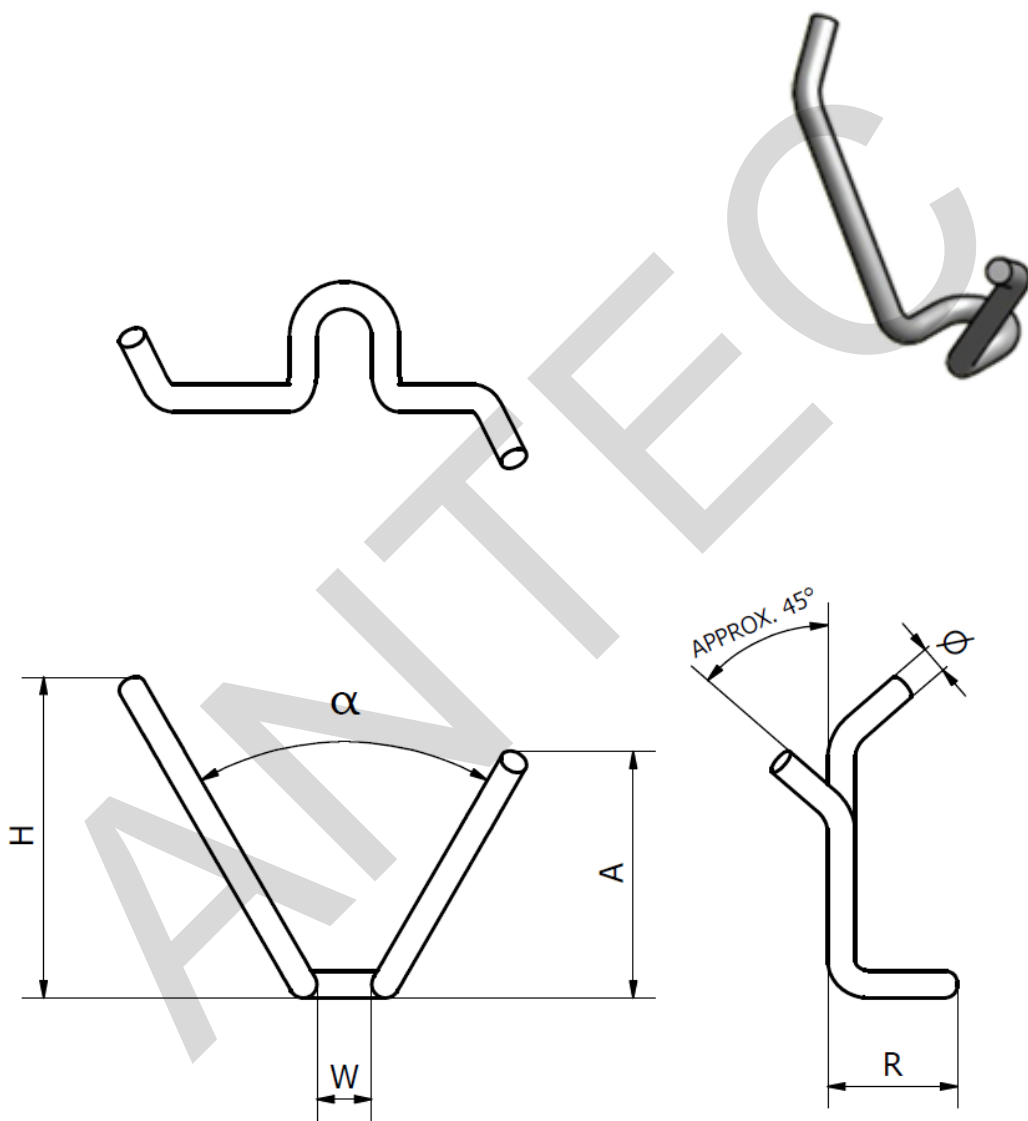

All items can be manufactured in various alloy steels.

Tolerances:

+/- 3mm on Dimensional

+/- 3° on Angular Dimensions

Unless otherwise noted.

STANDARD SIZES			
TYPE	H	A	ANGLE
WB 22	50	50	60
WB 32	75	50	60
WB 43	100	75	60
WB 54	125	100	60
WB 65	150	125	60

This drawing is the property of Antec Group Pty Ltd and is supplied on the understanding it is not to be used for any purpose, copied or communicated to any other person without written permission of the proprietor. All rights are reserved for product design concept. Antec products are guaranteed to conform within normal commercial tolerance of the applicable description furnished and to be manufactured from material as specified. No other guarantees or warranty, including warranty for fitness of products for in service operating condition shall exist in connection with sale of Antec products. Heat treatment after manufacture is not included unless specified.

Refractory Anchors

AN 12

WO Anchor

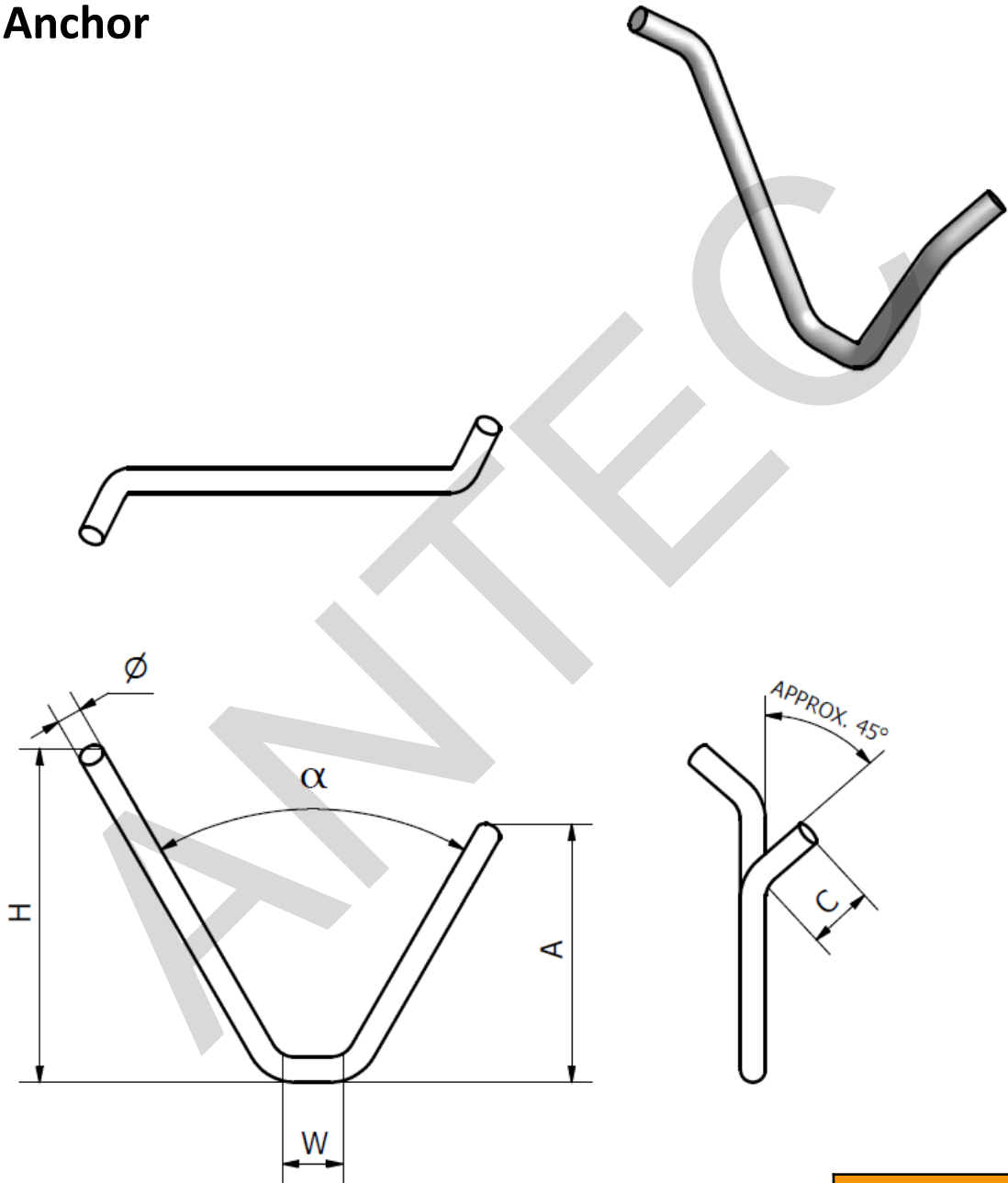

All items can be manufactured in various alloy steels.

Tolerances:

+/- 3mm on Dimensional

+/- 3° on Angular Dimensions

Unless otherwise noted.

STANDARD SIZES			
TYPE	H	A	ANGLE
WO 22	50	50	60
WO 32	75	50	60
WO 43	100	75	60
WO 54	125	100	60
WO 65	150	125	60

This drawing is the property of Antec Group Pty Ltd and is supplied on the understanding it is not to be used for any purpose, copied or communicated to any other person without written permission of the proprietor. All rights are reserved for product design concept. Antec products are guaranteed to conform within normal commercial tolerance of the applicable description furnished and to be manufactured from material as specified. No other guarantees or warranty, including warranty for fitness of products for in service operating condition shall exist in connection with sale of Antec products. Heat treatment after manufacture is not included unless specified.

Refractory Anchors

AN 13

WN Anchor

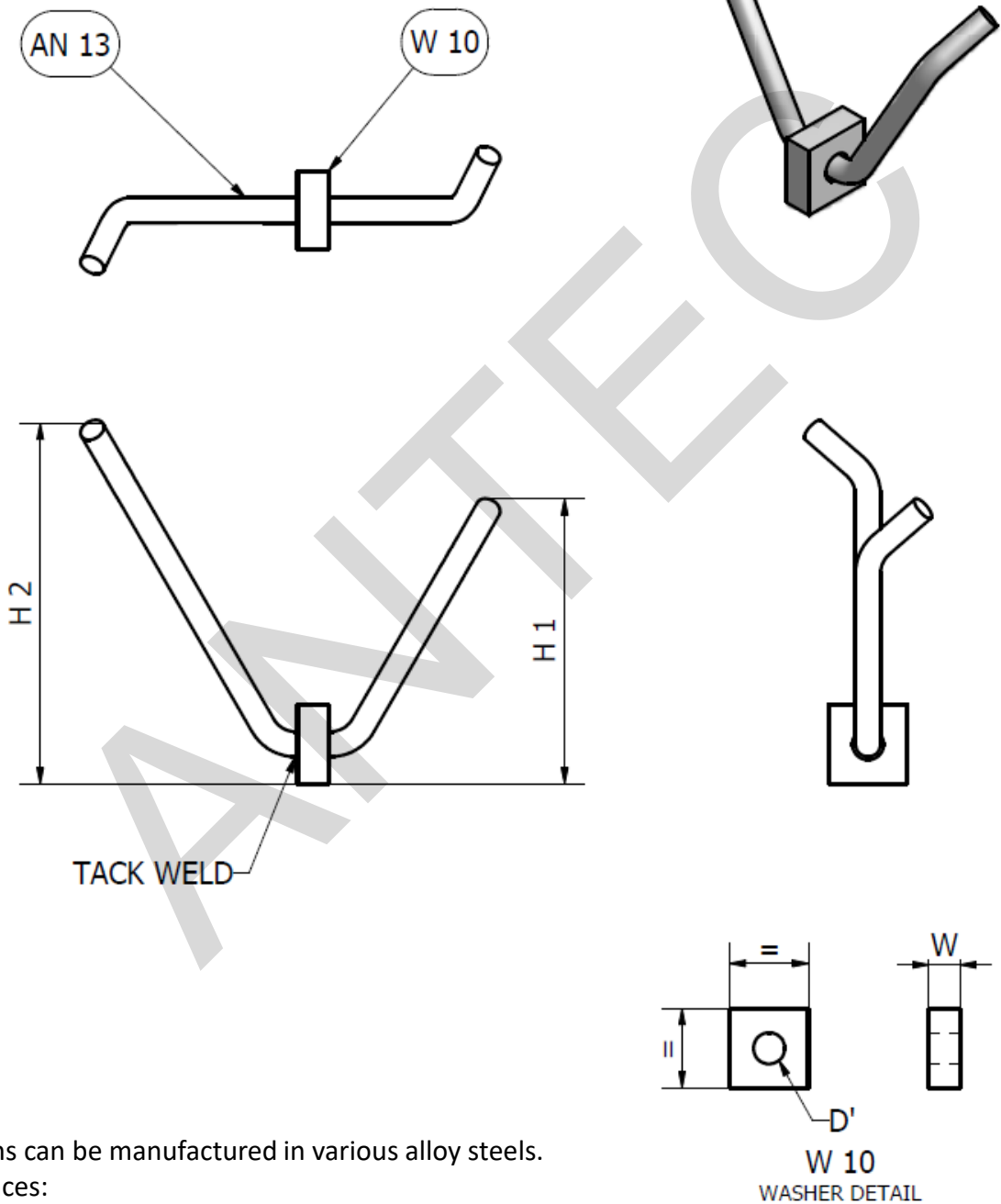

All items can be manufactured in various alloy steels.

Tolerances:

+/- 3mm on Dimensional

+/- 3° on Angular Dimensions

Unless otherwise noted.

This drawing is the property of Antec Group Pty Ltd and is supplied on the understanding it is not to be used for any purpose, copied or communicated to any other person without written permission of the proprietor. All rights are reserved for product design concept. Antec products are guaranteed to conform within normal commercial tolerance of the applicable description furnished and to be manufactured from material as specified. No other guarantees or warranty, including warranty for fitness of products for in service operating condition shall exist in connection with sale of Antec products. Heat treatment after manufacture is not included unless specified.

Refractory Anchors

AN 13A

VCPW Anchor

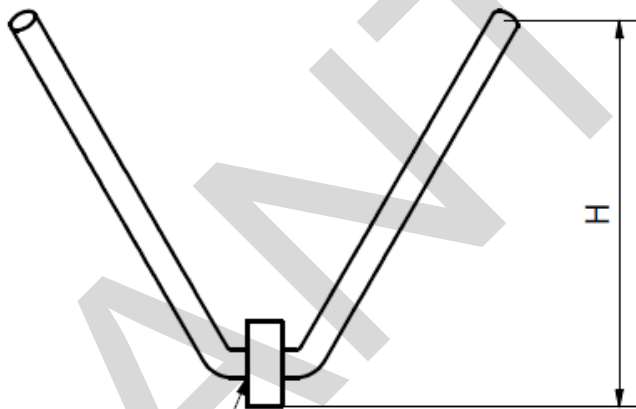
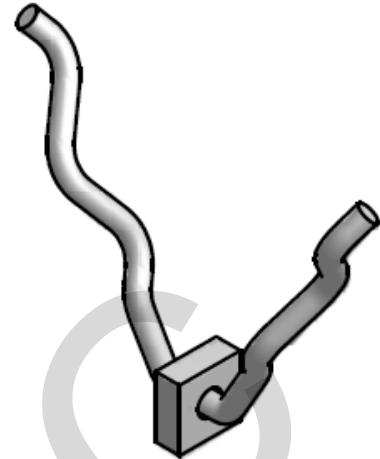
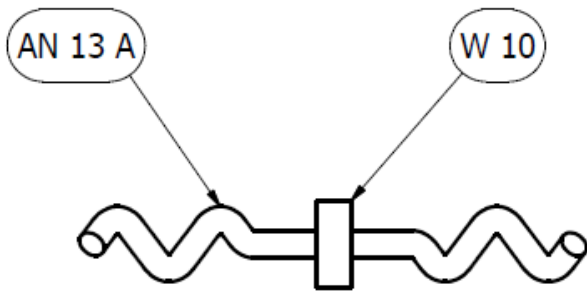

TACK WELD

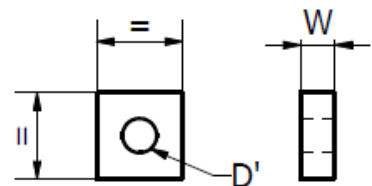

W 10
WASHER DETAIL

All items can be manufactured in various alloy steels.

Tolerances:

+/- 3mm on Dimensional

+/- 3° on Angular Dimensions

Unless otherwise noted

Corrugation as drawn is diagrammatic only.

This drawing is the property of Antec Group Pty Ltd and is supplied on the understanding it is not to be used for any purpose, copied or communicated to any other person without written permission of the proprietor. All rights are reserved for product design concept. Antec products are guaranteed to conform within normal commercial tolerance of the applicable description furnished and to be manufactured from material as specified. No other guarantees or warranty, including warranty for fitness of products for in service operating condition shall exist in connection with sale of Antec products. Heat treatment after manufacture is not included unless specified.

Refractory Anchors

AN 14

Anchors & Nuts

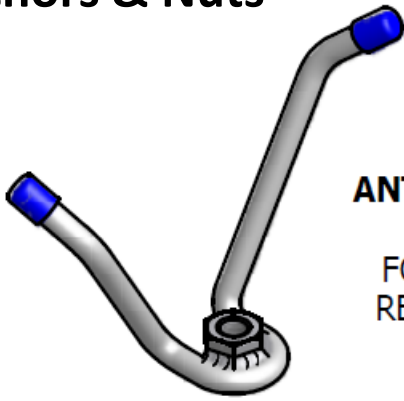

ANTEC WBN ANCHOR

FOR ANCHOR DETAIL
REFER TO DWG AN 11

ANTEC VCLN ANCHOR

FOR ANCHOR DETAIL
REFER TO DWG AN 03

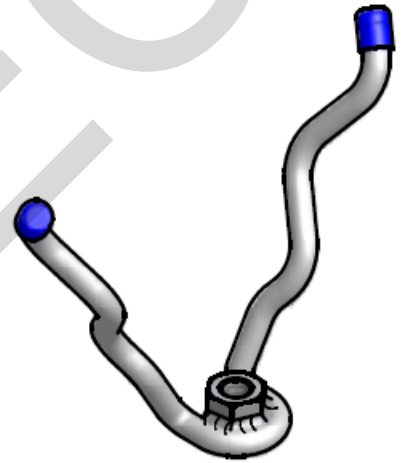

ANTEC YCLN ANCHOR

FOR ANCHOR DETAIL
REFER TO DWG AN 05

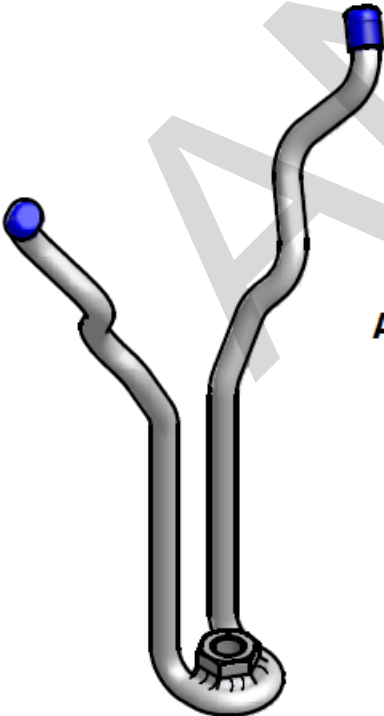

Refractory Anchors

AN 14A

Anchors & Bolts



ANTEC WBB ANCHOR

FOR ANCHOR DETAIL
REFER TO DWG AN 11

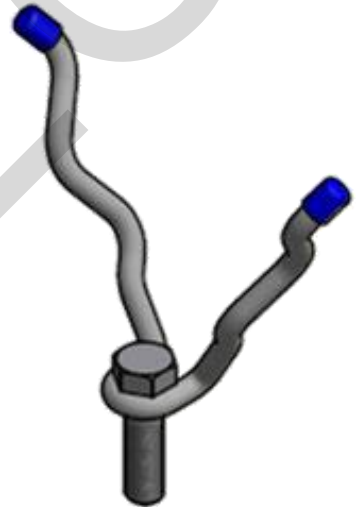

ANTEC VCLB ANCHOR

FOR ANCHOR DETAIL
REFER TO DWG AN 03

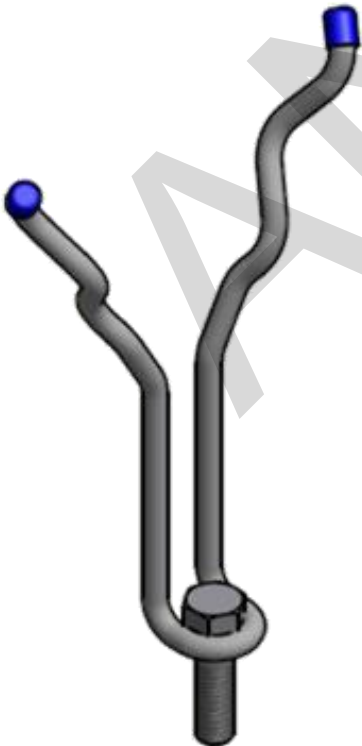

ANTEC YCLB ANCHOR

FOR ANCHOR DETAIL
REFER TO DWG AN 05

Refractory Anchors

AN 15

Anchor Studs

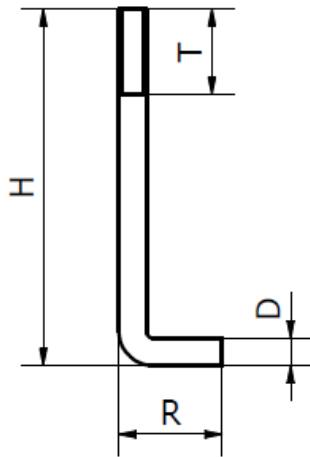

S1 STUD

S2 STUD

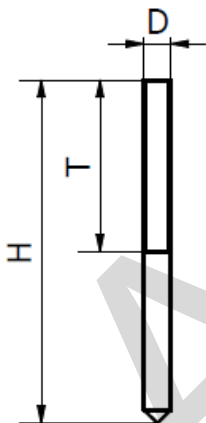
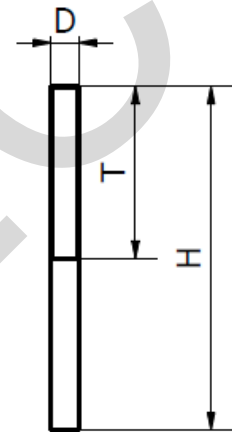

S3 STUD

(FOR STUD WELDING APPLICATIONS)

S4 STUD
(STANDARD SIZE AS AVAILABLE)

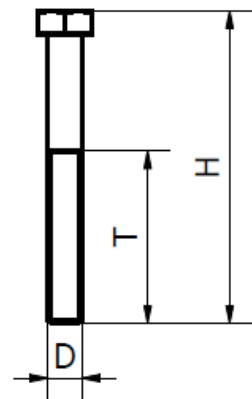

All items can be manufactured in various alloy steels.

Tolerances:

+/- 3mm on Dimensional

+/- 3° on Angular Dimensions

Unless otherwise noted.

This drawing is the property of Antec Group Pty Ltd and is supplied on the understanding it is not to be used for any purpose, copied or communicated to any other person without written permission of the proprietor. All rights are reserved for product design concept. Antec products are guaranteed to conform within normal commercial tolerance of the applicable description furnished and to be manufactured from material as specified. No other guarantees or warranty, including warranty for fitness of products for in service operating condition shall exist in connection with sale of Antec products. Heat treatment after manufacture is not included unless specified.

Refractory Anchors

AN 16

YDX Anchor

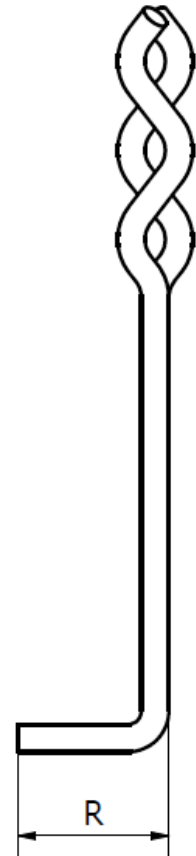
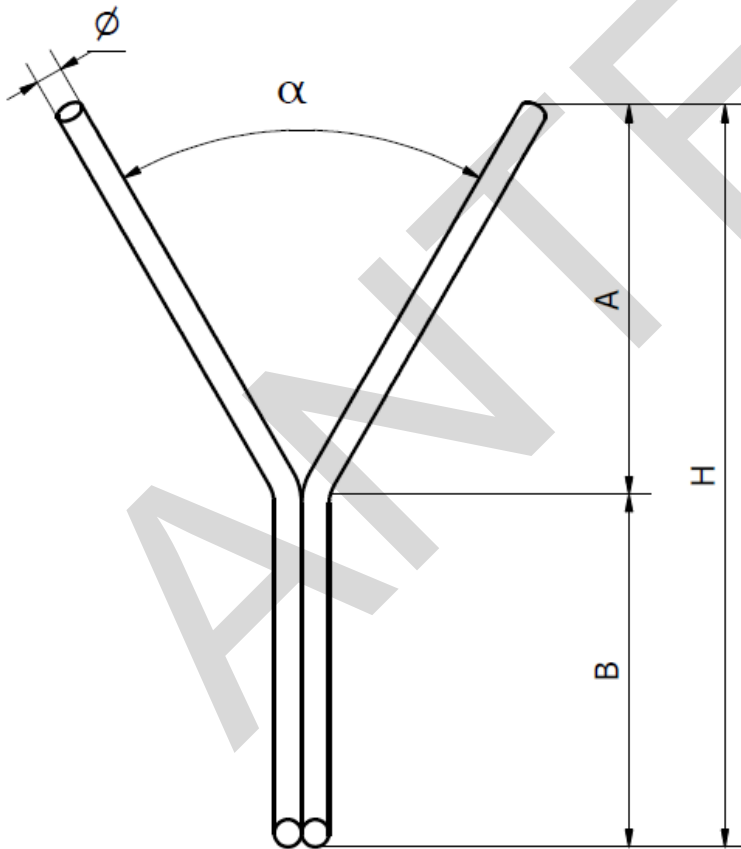
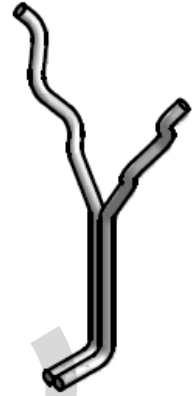
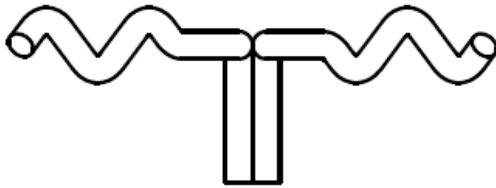

All items can be manufactured in various alloy steels.

Tolerances:

+/- 3mm on Dimensional

+/- 3° on Angular Dimensions

Unless otherwise noted

Corrugation as drawn is diagrammatic only.

This drawing is the property of Antec Group Pty Ltd and is supplied on the understanding it is not to be used for any purpose, copied or communicated to any other person without written permission of the proprietor. All rights are reserved for product design concept. Antec products are guaranteed to conform within normal commercial tolerance of the applicable description furnished and to be manufactured from material as specified. No other guarantees or warranty, including warranty for fitness of products for in service operating condition shall exist in connection with sale of Antec products. Heat treatment after manufacture is not included unless specified.

Refractory Anchors

AN 17

YD2X Anchor

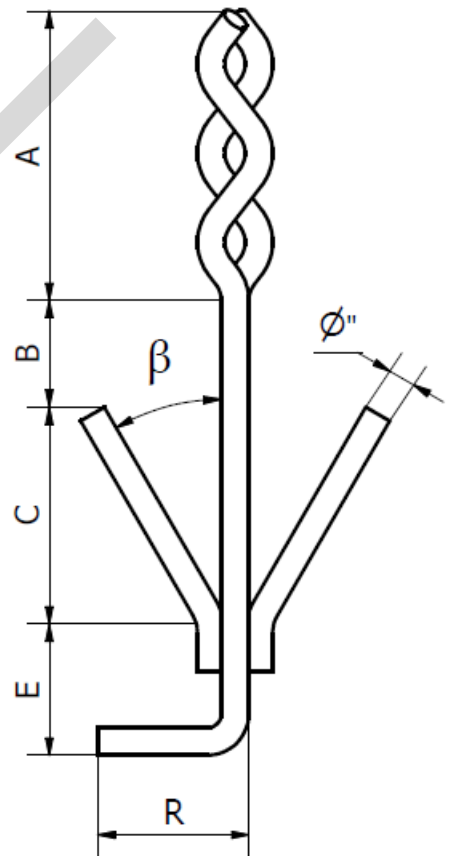
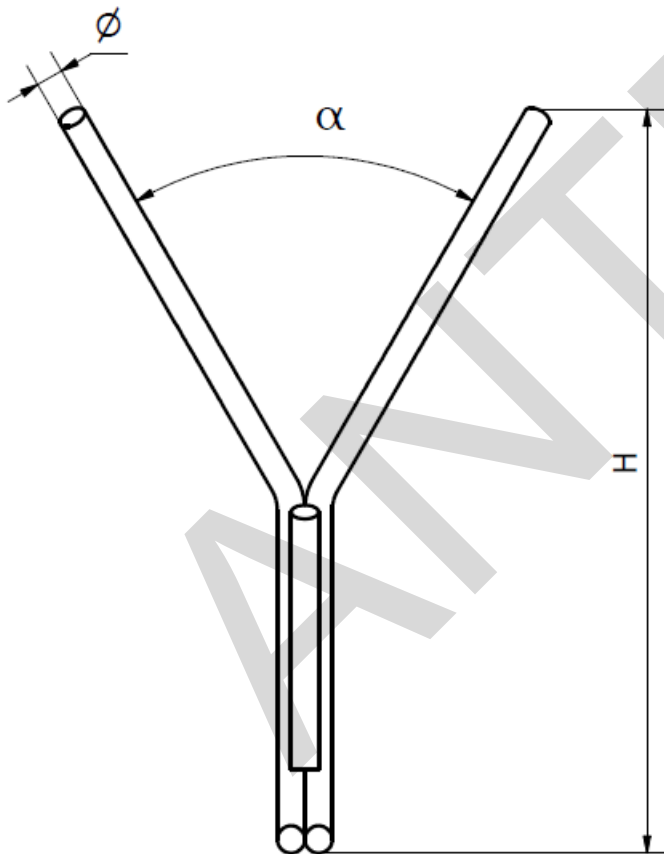
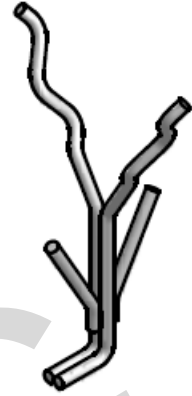
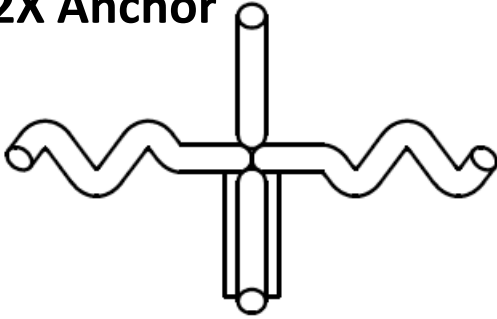

All items can be manufactured in various alloy steels.

Tolerances:

+/- 3mm on Dimensional

+/- 3° on Angular Dimensions

Unless otherwise noted

Corrugation as drawn is diagrammatic only.

$E_{\min} = 25\text{mm}$ $W_{\min} = 15\text{mm}$

This drawing is the property of Antec Group Pty Ltd and is supplied on the understanding it is not to be used for any purpose, copied or communicated to any other person without written permission of the proprietor. All rights are reserved for product design concept. Antec products are guaranteed to conform within normal commercial tolerance of the applicable description furnished and to be manufactured from material as specified. No other guarantees or warranty, including warranty for fitness of products for in service operating condition shall exist in connection with sale of Antec products. Heat treatment after manufacture is not included unless specified.

Refractory Anchors

AN 17A

QN8 Anchor

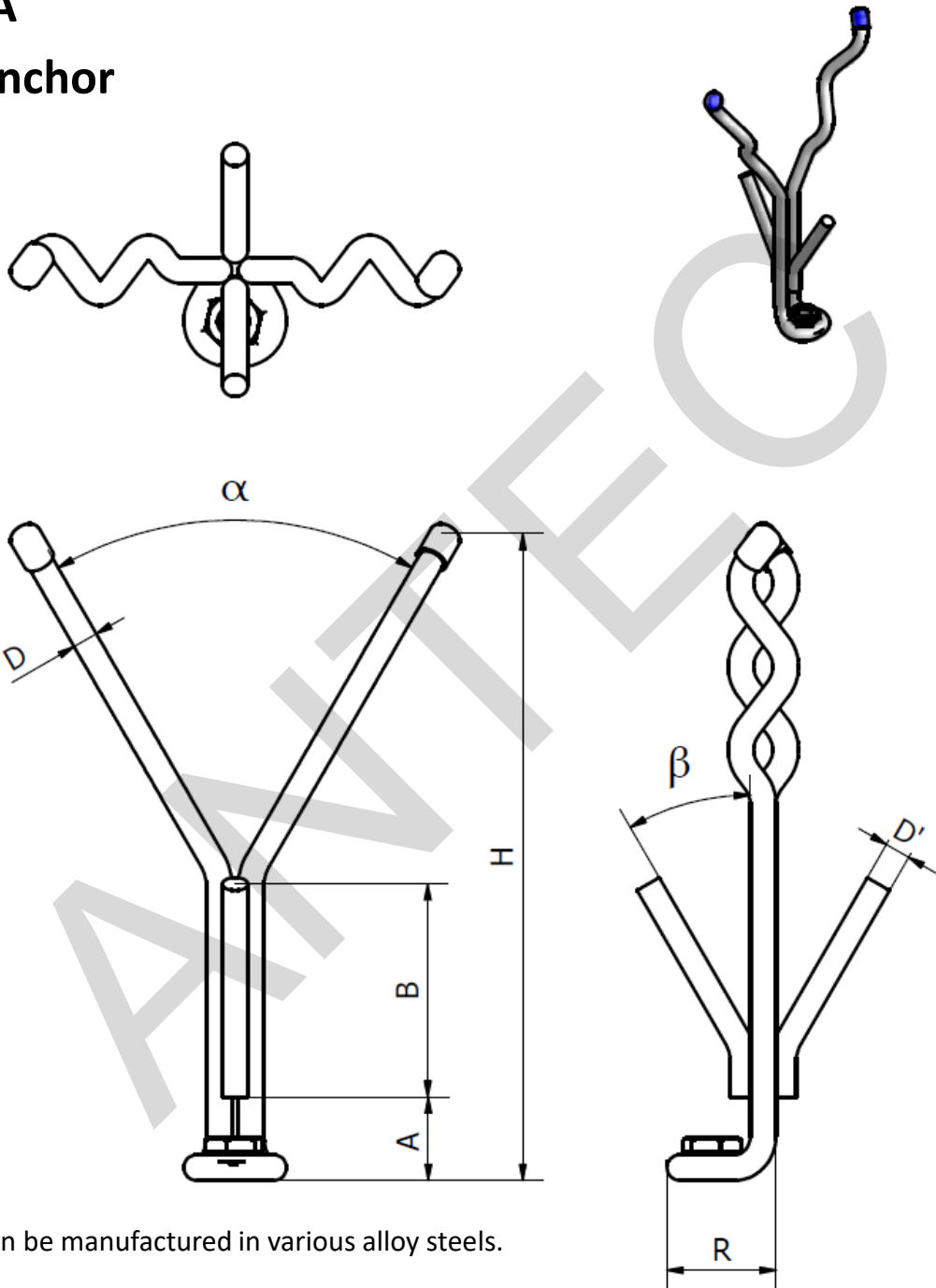

All items can be manufactured in various alloy steels.

Tolerances:

+/- 3mm on Dimensional

+/- 3° on Angular Dimensions

Unless otherwise noted

Corrugation as drawn is diagrammatic only.

Grade & Size of Nut to be specified by the Customer.

This drawing is the property of Antec Group Pty Ltd and is supplied on the understanding it is not to be used for any purpose, copied or communicated to any other person without written permission of the proprietor. All rights are reserved for product design concept. Antec products are guaranteed to conform within normal commercial tolerance of the applicable description furnished and to be manufactured from material as specified. No other guarantees or warranty, including warranty for fitness of products for in service operating condition shall exist in connection with sale of Antec products. Heat treatment after manufacture is not included unless specified.

Refractory Anchors

AN 18

YX-C Anchor

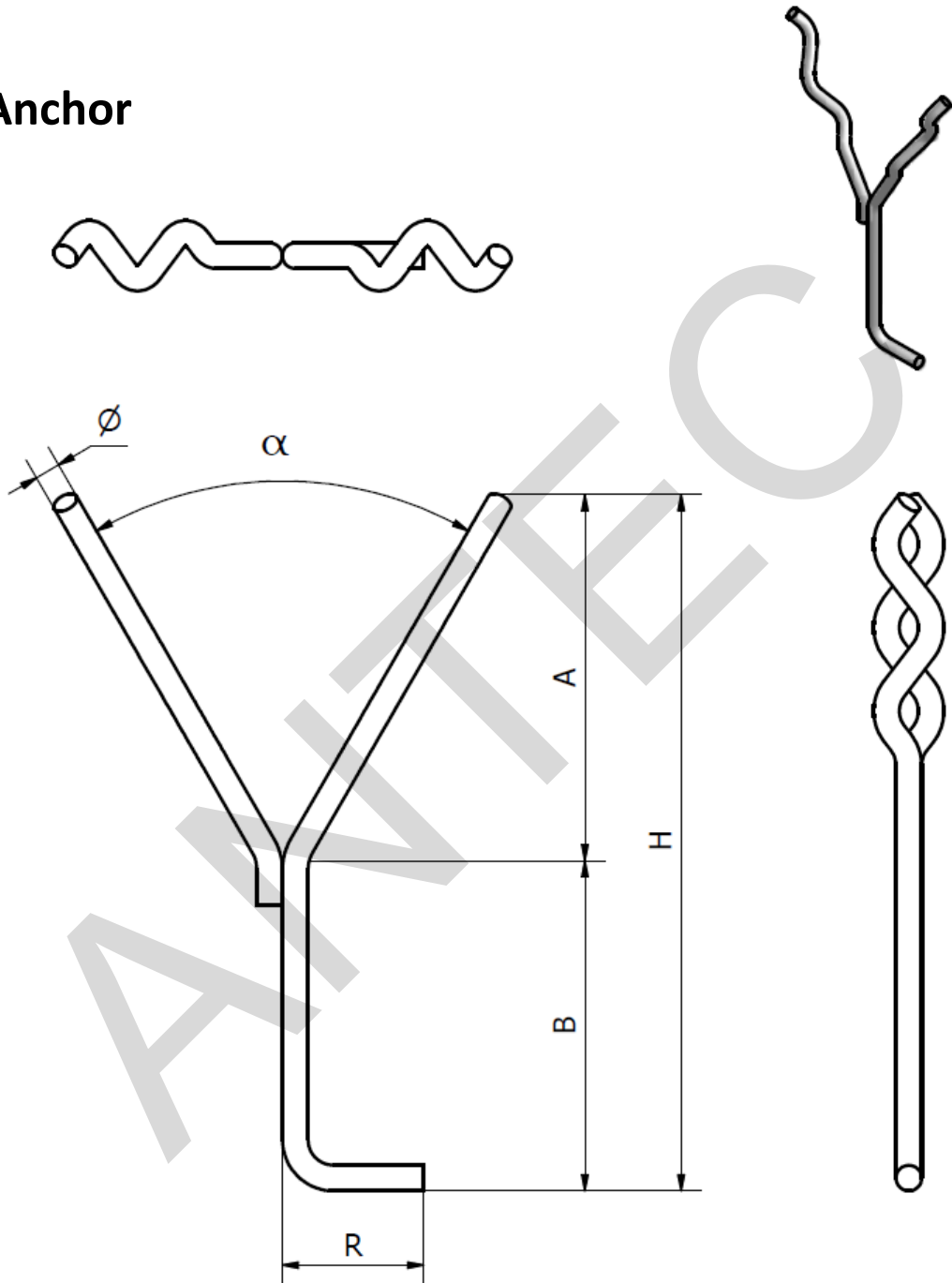

All items can be manufactured in various alloy steels.

Tolerances:

+/- 3mm on Dimensional

+/- 3° on Angular Dimensions

Unless otherwise noted

Corrugation as drawn is diagrammatic only.

This drawing is the property of Antec Group Pty Ltd and is supplied on the understanding it is not to be used for any purpose, copied or communicated to any other person without written permission of the proprietor. All rights are reserved for product design concept. Antec products are guaranteed to conform within normal commercial tolerance of the applicable description furnished and to be manufactured from material as specified. No other guarantees or warranty, including warranty for fitness of products for in service operating condition shall exist in connection with sale of Antec products. Heat treatment after manufacture is not included unless specified.

Refractory Anchors

AN 18A

YX-CVCP Anchor
(Threaded)

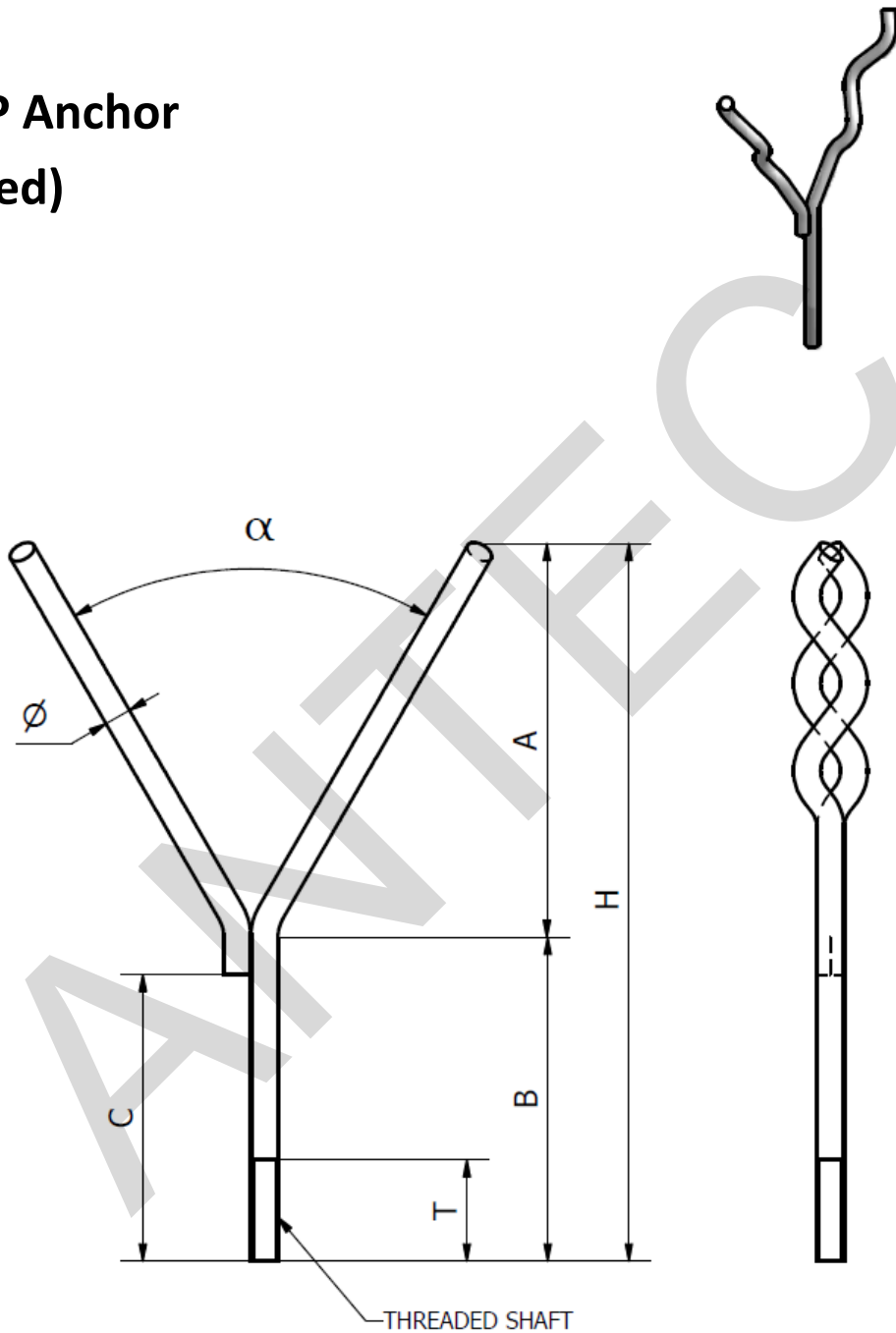

All items can be manufactured in various alloy steels.

Tolerances:

+/- 3mm on Dimensional

+/- 3° on Angular Dimensions

Unless otherwise noted

Corrugation as drawn is diagrammatic only.

This drawing is the property of Antec Group Pty Ltd and is supplied on the understanding it is not to be used for any purpose, copied or communicated to any other person without written permission of the proprietor. All rights are reserved for product design concept. Antec products are guaranteed to conform within normal commercial tolerance of the applicable description furnished and to be manufactured from material as specified. No other guarantees or warranty, including warranty for fitness of products for in service operating condition shall exist in connection with sale of Antec products. Heat treatment after manufacture is not included unless specified.

Refractory Anchors

AN 19

YX-CH Anchor

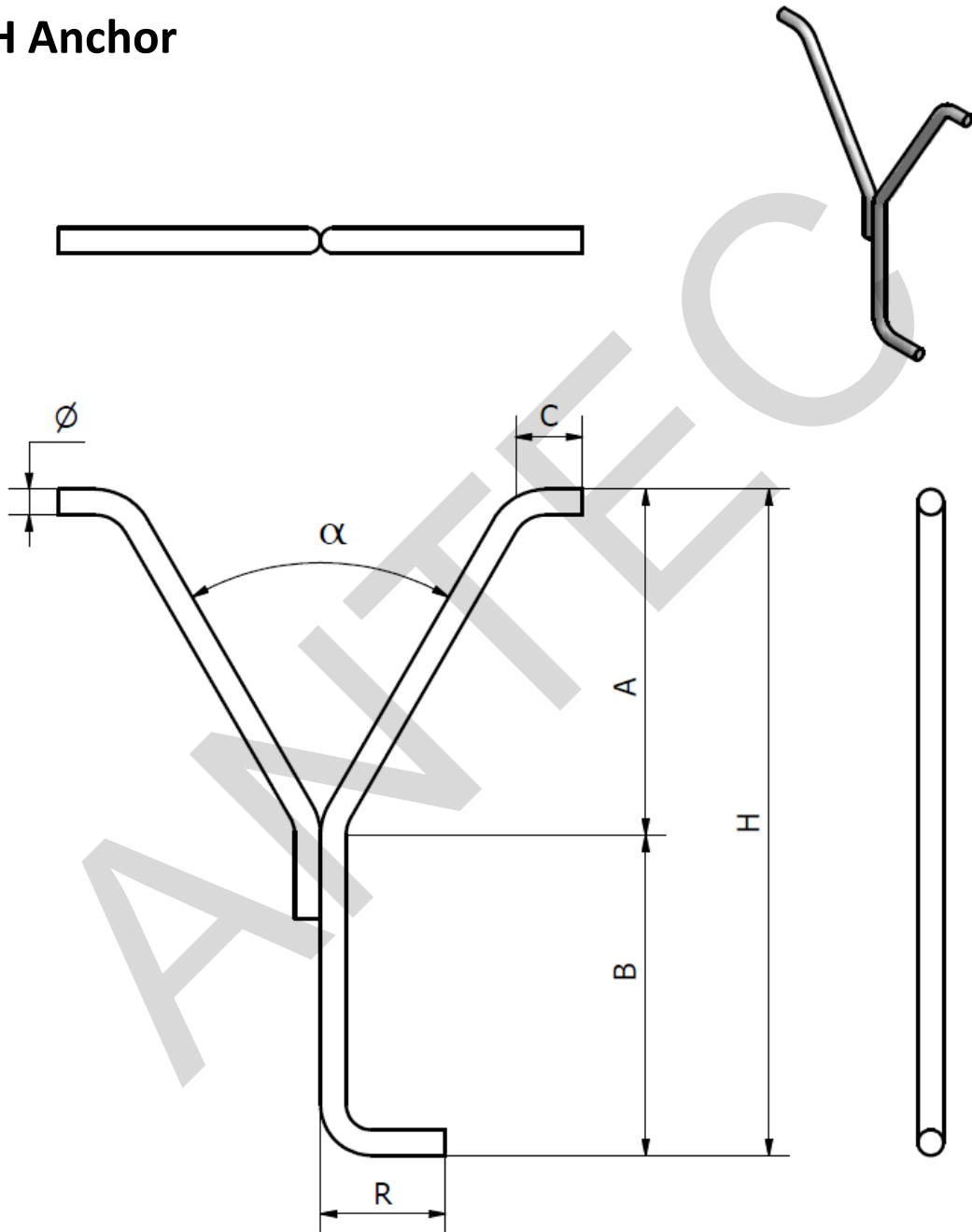

All items can be manufactured in various alloy steels.

Tolerances:

+/- 3mm on Dimensional

+/- 3° on Angular Dimensions

Unless otherwise noted.

This drawing is the property of Antec Group Pty Ltd and is supplied on the understanding it is not to be used for any purpose, copied or communicated to any other person without written permission of the proprietor. All rights are reserved for product design concept. Antec products are guaranteed to conform within normal commercial tolerance of the applicable description furnished and to be manufactured from material as specified. No other guarantees or warranty, including warranty for fitness of products for in service operating condition shall exist in connection with sale of Antec products. Heat treatment after manufacture is not included unless specified.

Refractory Anchors

AN 20

Drive In Anchor

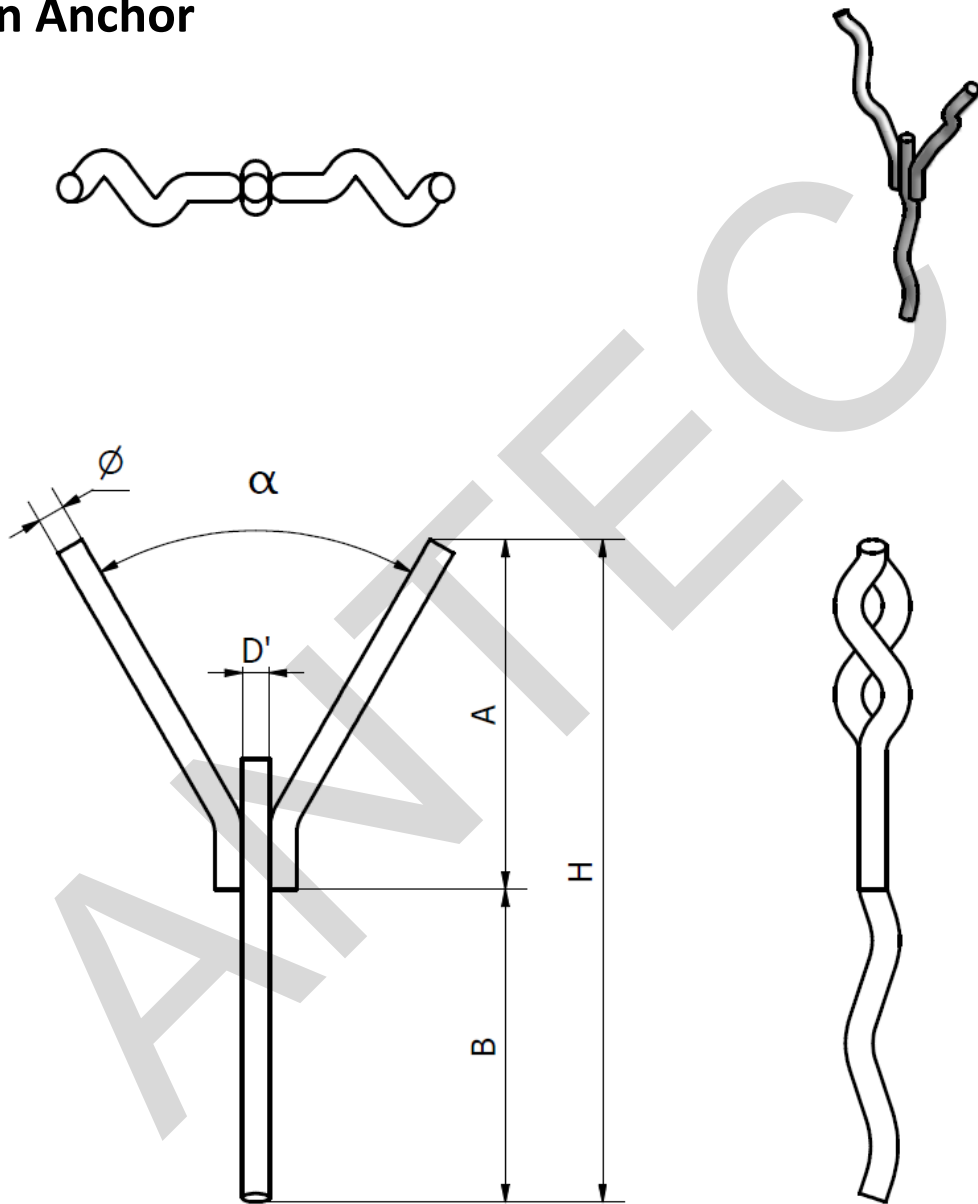

All items can be manufactured in various alloy steels.

Tolerances:

+/- 3mm on Dimensional

+/- 3° on Angular Dimensions

Unless otherwise noted

Corrugation as drawn is diagrammatic only.

Drill Size = +2mm on material diameter i.e. 6mm = M8 Drill

This drawing is the property of Antec Group Pty Ltd and is supplied on the understanding it is not to be used for any purpose, copied or communicated to any other person without written permission of the proprietor. All rights are reserved for product design concept. Antec products are guaranteed to conform within normal commercial tolerance of the applicable description furnished and to be manufactured from material as specified. No other guarantees or warranty, including warranty for fitness of products for in service operating condition shall exist in connection with sale of Antec products. Heat treatment after manufacture is not included unless specified.

Refractory Anchors

AN 21

Twist Anchor

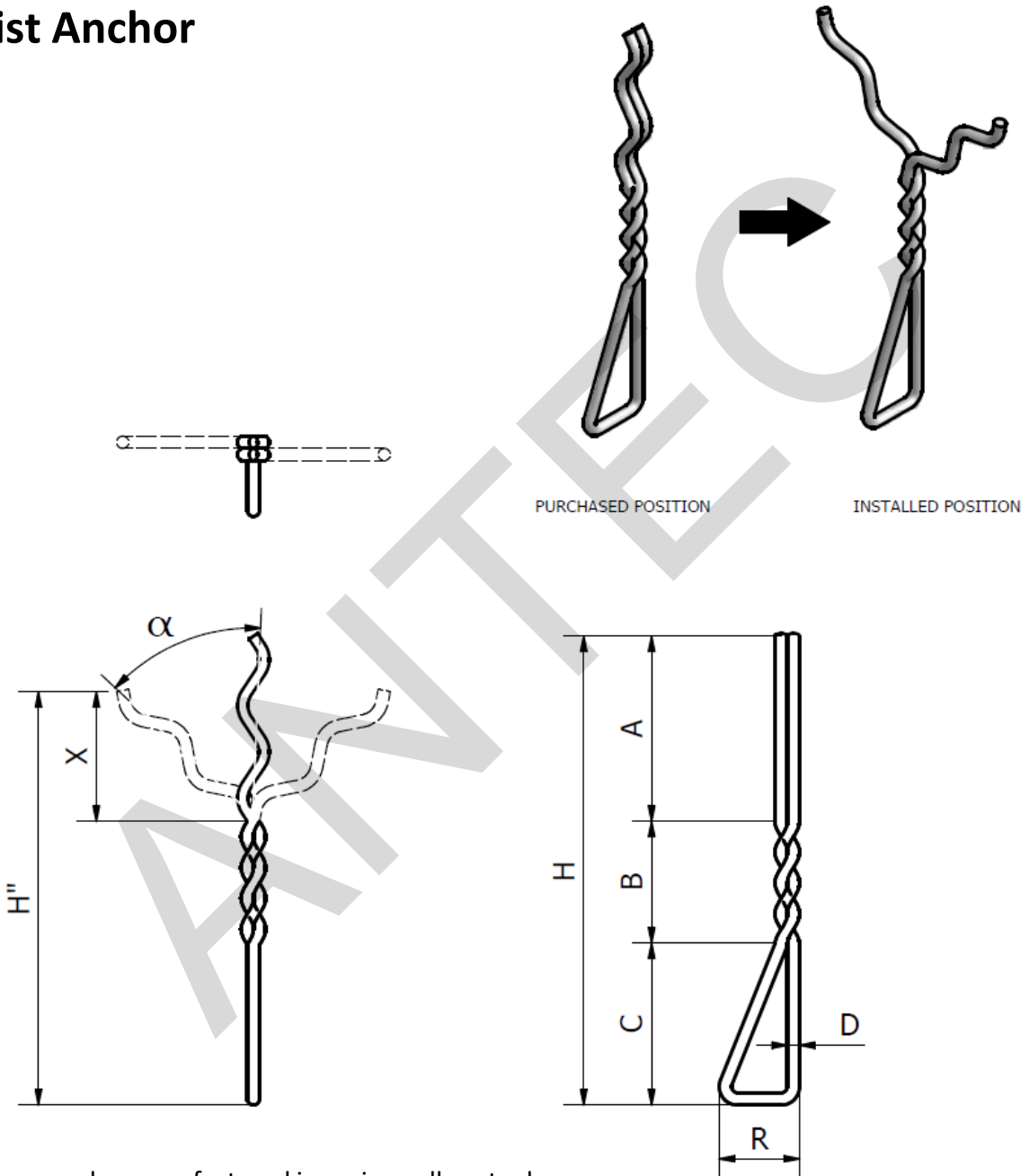

All items can be manufactured in various alloy steels.

Tolerances:

+/- 3mm on Dimensional

+/- 3° on Angular Dimensions

Unless otherwise noted

Corrugation as drawn is diagrammatic only.

This drawing is the property of Antec Group Pty Ltd and is supplied on the understanding it is not to be used for any purpose, copied or communicated to any other person without written permission of the proprietor. All rights are reserved for product design concept. Antec products are guaranteed to conform within normal commercial tolerance of the applicable description furnished and to be manufactured from material as specified. No other guarantees or warranty, including warranty for fitness of products for in service operating condition shall exist in connection with sale of Antec products. Heat treatment after manufacture is not included unless specified.

Refractory Anchors

AN 22

Triangular Base Anchor

VERTICAL TYPE

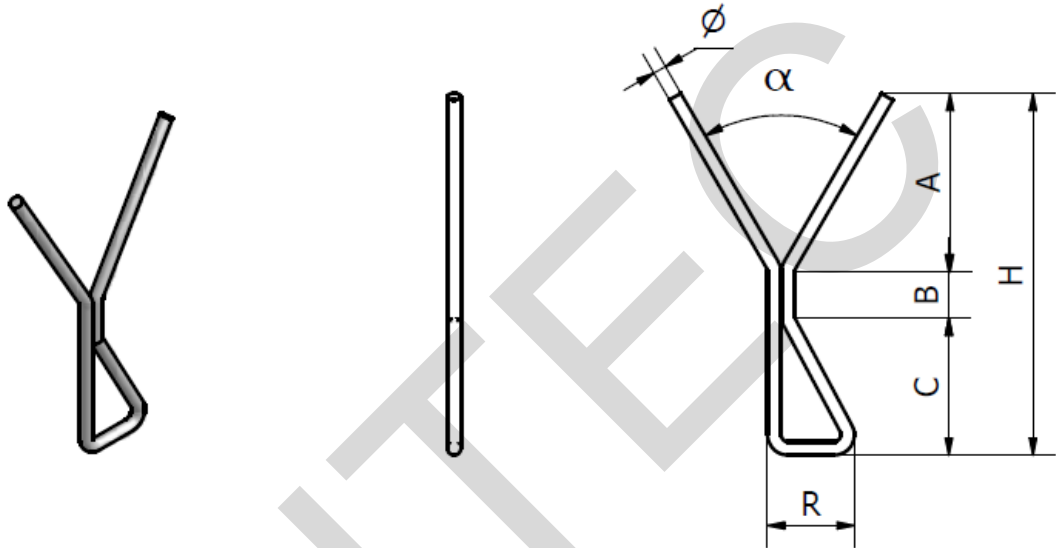

HORIZONTAL TYPE

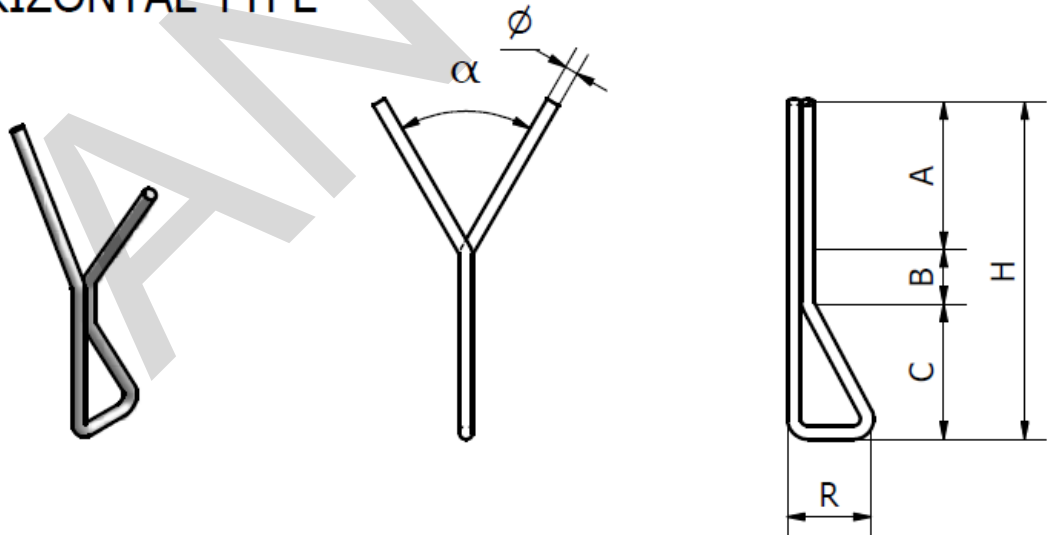

All items can be manufactured in various alloy steels.

Tolerances:

+/- 3mm on Dimensional

+/- 3° on Angular Dimensions

Unless otherwise noted.

This drawing is the property of Antec Group Pty Ltd and is supplied on the understanding it is not to be used for any purpose, copied or communicated to any other person without written permission of the proprietor. All rights are reserved for product design concept. Antec products are guaranteed to conform within normal commercial tolerance of the applicable description furnished and to be manufactured from material as specified. No other guarantees or warranty, including warranty for fitness of products for in service operating condition shall exist in connection with sale of Antec products. Heat treatment after manufacture is not included unless specified.

Refractory Anchors

AN 23

Split Tyne Anchor
(Corrugated)

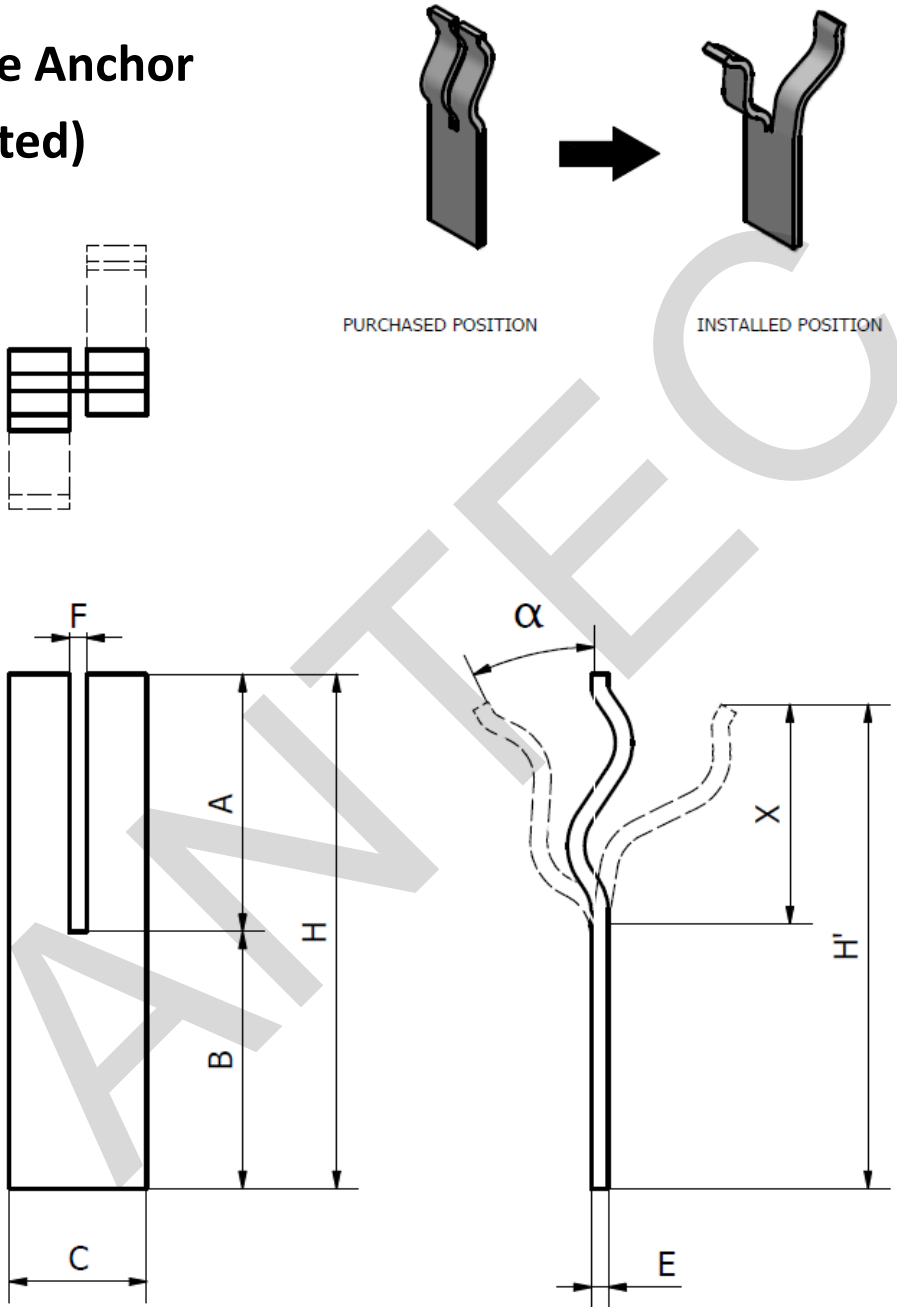

All items can be manufactured in various alloy steels.

Tolerances:

+/- 3mm on Dimensional

+/- 3° on Angular Dimensions

Unless otherwise noted

Corrugation as drawn is diagrammatic only.

This drawing is the property of Antec Group Pty Ltd and is supplied on the understanding it is not to be used for any purpose, copied or communicated to any other person without written permission of the proprietor. All rights are reserved for product design concept. Antec products are guaranteed to conform within normal commercial tolerance of the applicable description furnished and to be manufactured from material as specified. No other guarantees or warranty, including warranty for fitness of products for in service operating condition shall exist in connection with sale of Antec products. Heat treatment after manufacture is not included unless specified.

Refractory Anchors

AN 24

Split Tyne Anchor

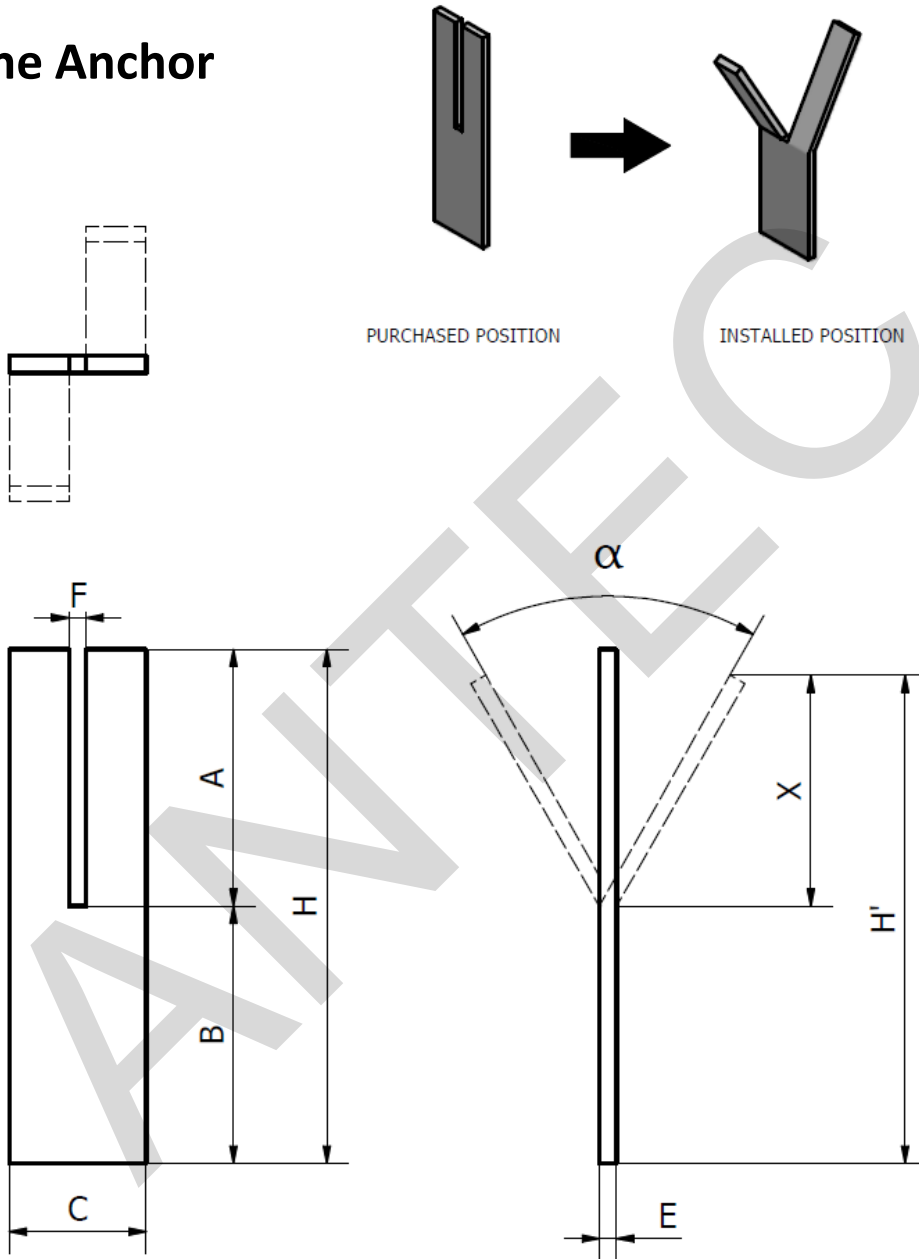

All items can be manufactured in various alloy steels.

Tolerances:

+/- 3mm on Dimensional

+/- 3° on Angular Dimensions

Unless otherwise noted.

$E_{\min} = 3\text{mm}$ $E_{\max} = 5\text{mm}$

$F_{\min} = 5\text{mm}$ $C_{\min} = 25\text{mm}$ $A_{\max} = 100\text{mm}$

This drawing is the property of Antec Group Pty Ltd and is supplied on the understanding it is not to be used for any purpose, copied or communicated to any other person without written permission of the proprietor. All rights are reserved for product design concept. Antec products are guaranteed to conform within normal commercial tolerance of the applicable description furnished and to be manufactured from material as specified. No other guarantees or warranty, including warranty for fitness of products for in service operating condition shall exist in connection with sale of Antec products. Heat treatment after manufacture is not included unless specified.

Refractory Anchors

AN 25

SVP Anchor

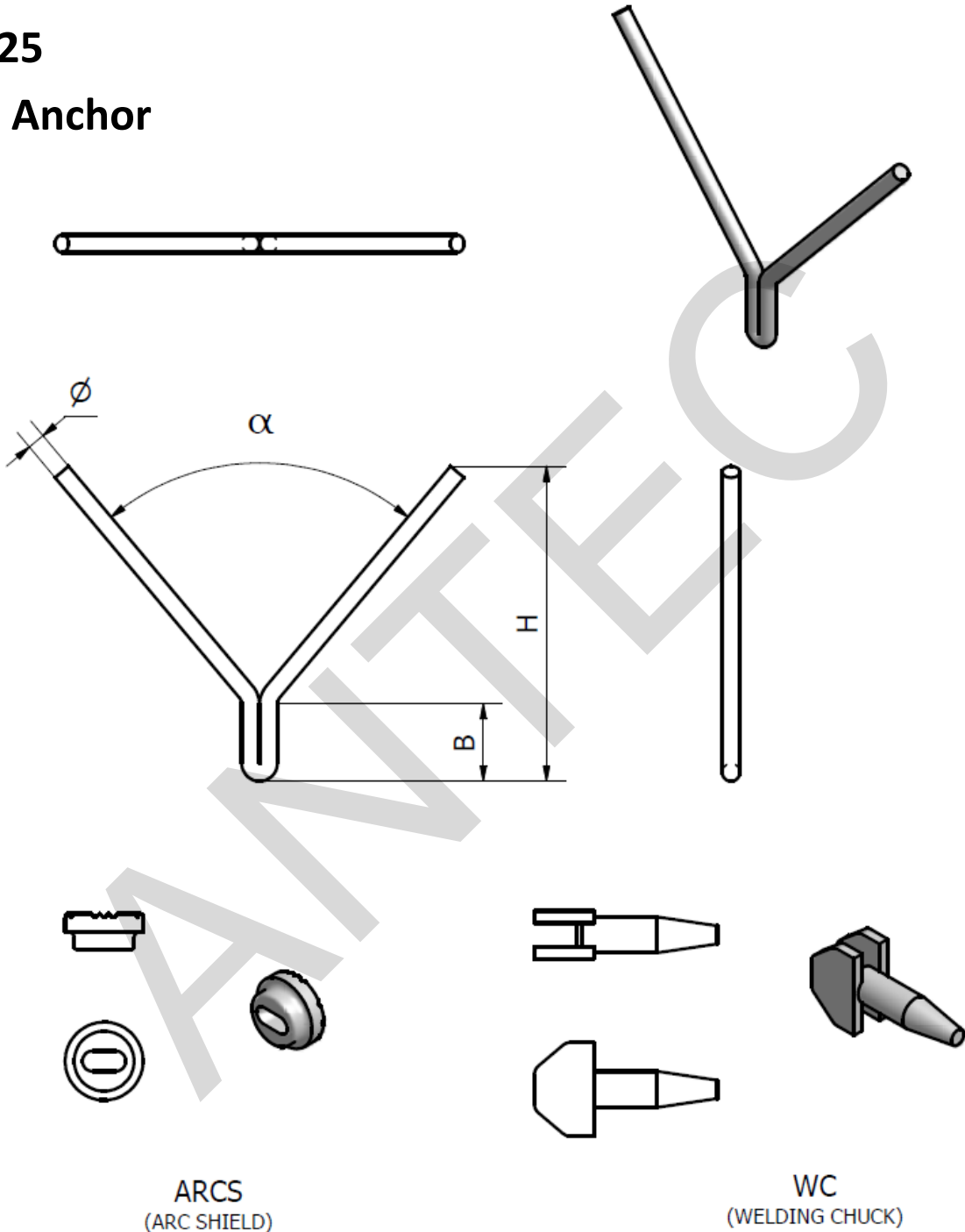

ARCS
(ARC SHIELD)

WC
(WELDING CHUCK)

All items can be manufactured in various alloy steels.

Tolerances:

+/- 3mm on Dimensional

+/- 3° on Angular Dimensions

Unless otherwise noted.

This drawing is the property of Antec Group Pty Ltd and is supplied on the understanding it is not to be used for any purpose, copied or communicated to any other person without written permission of the proprietor. All rights are reserved for product design concept. Antec products are guaranteed to conform within normal commercial tolerance of the applicable description furnished and to be manufactured from material as specified. No other guarantees or warranty, including warranty for fitness of products for in service operating condition shall exist in connection with sale of Antec products. Heat treatment after manufacture is not included unless specified.

Refractory Anchors

AN 26

SVC Anchor

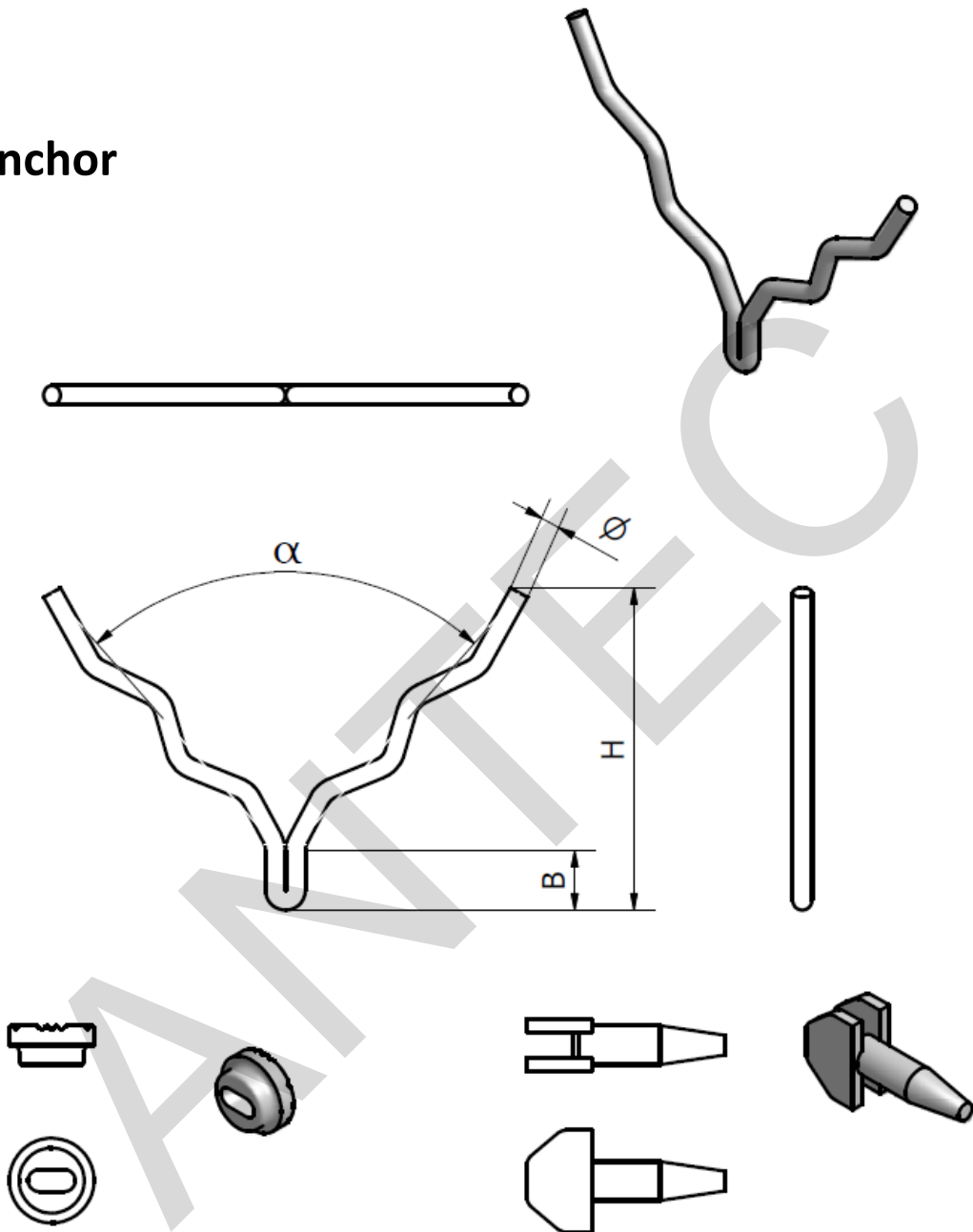

ARCS
(ARC SHIELD)

WC
(WELDING CHUCK)

All items can be manufactured in various alloy steels.

Tolerances:

+/- 3mm on Dimensional

+/- 3° on Angular Dimensions

Unless otherwise noted

Corrugation as drawn is diagrammatic only.

This drawing is the property of Antec Group Pty Ltd and is supplied on the understanding it is not to be used for any purpose, copied or communicated to any other person without written permission of the proprietor. All rights are reserved for product design concept. Antec products are guaranteed to conform within normal commercial tolerance of the applicable description furnished and to be manufactured from material as specified. No other guarantees or warranty, including warranty for fitness of products for in service operating condition shall exist in connection with sale of Antec products. Heat treatment after manufacture is not included unless specified.

Refractory Anchors

AN 27

SCH Anchor

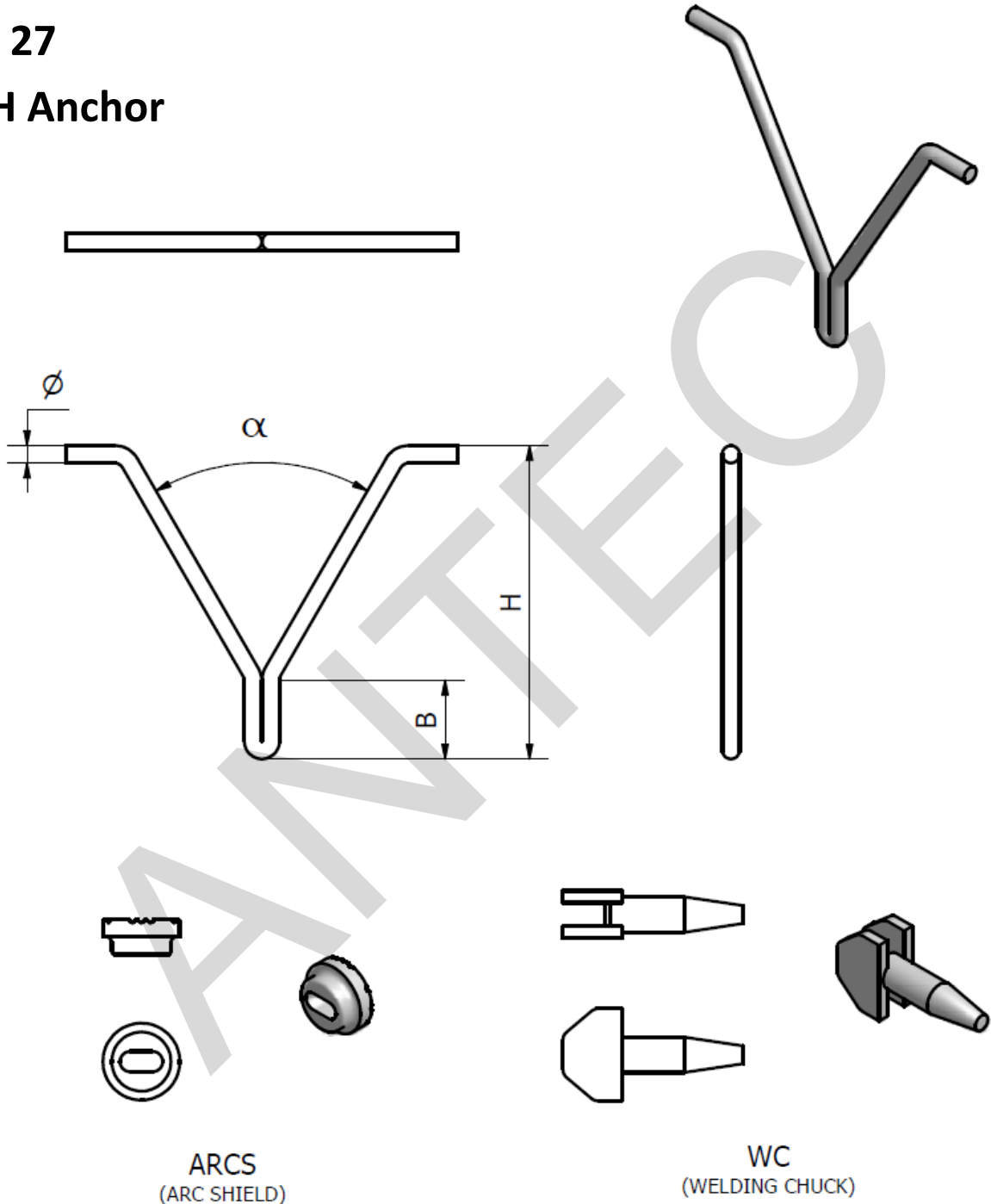

All items can be manufactured in various alloy steels.

Tolerances:

+/- 3mm on Dimensional

+/- 3° on Angular Dimensions

Unless otherwise noted.

This drawing is the property of Antec Group Pty Ltd and is supplied on the understanding it is not to be used for any purpose, copied or communicated to any other person without written permission of the proprietor. All rights are reserved for product design concept. Antec products are guaranteed to conform within normal commercial tolerance of the applicable description furnished and to be manufactured from material as specified. No other guarantees or warranty, including warranty for fitness of products for in service operating condition shall exist in connection with sale of Antec products. Heat treatment after manufacture is not included unless specified.

Refractory Anchors

AN 28

SHP Anchor

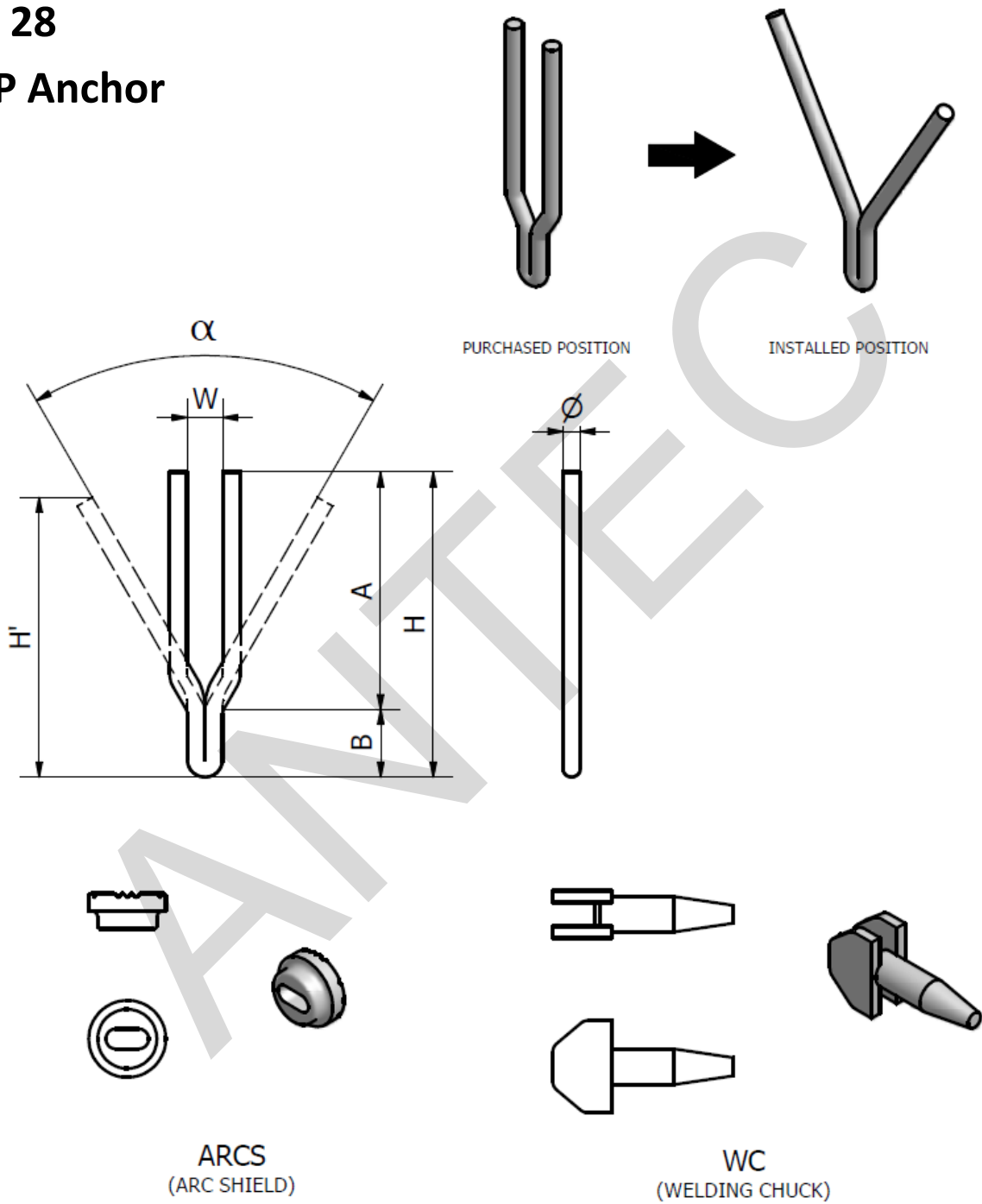

ARCS
(ARC SHIELD)

WC
(WELDING CHUCK)

All items can be manufactured in various alloy steels.

Tolerances:

- +/- 3mm on Dimensional
- +/- 3° on Angular Dimensions
- Unless otherwise noted.

This drawing is the property of Antec Group Pty Ltd and is supplied on the understanding it is not to be used for any purpose, copied or communicated to any other person without written permission of the proprietor. All rights are reserved for product design concept. Antec products are guaranteed to conform within normal commercial tolerance of the applicable description furnished and to be manufactured from material as specified. No other guarantees or warranty, including warranty for fitness of products for in service operating condition shall exist in connection with sale of Antec products. Heat treatment after manufacture is not included unless specified.

Refractory Anchors

AN 29A

Rotalock System Mark I Type

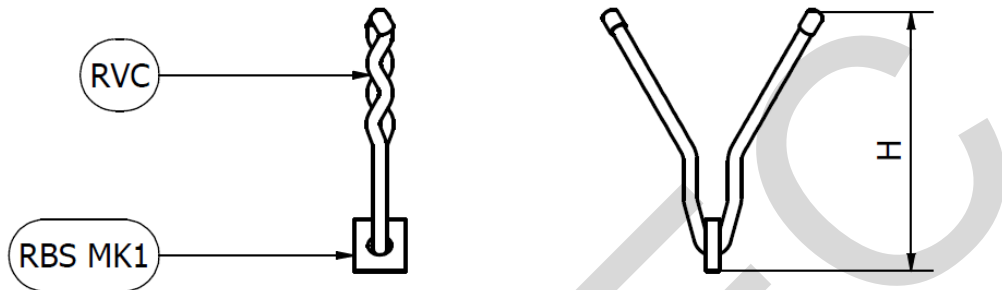

ASSEMBLED MARK 1 ROTALOCK ANCHOR SYSTEM

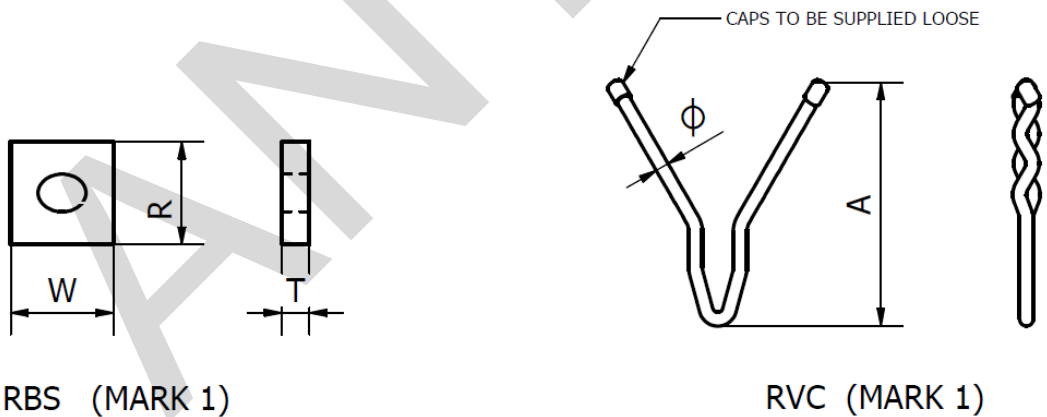

RBS (MARK 1)

RVC (MARK 1)

All items can be manufactured in various alloy steels.

RBS Bases can be manufactured in carbon steel, 304, 310, 253 MA or high nickel alloy.

Edges rounded on RBS if manufactured in carbon steel.

Tolerances:

+/- 3mm on Dimensional

+/- 3° on Angular Dimensions

Unless otherwise noted.

This drawing is the property of Antec Group Pty Ltd and is supplied on the understanding it is not to be used for any purpose, copied or communicated to any other person without written permission of the proprietor. All rights are reserved for product design concept. Antec products are guaranteed to conform within normal commercial tolerance of the applicable description furnished and to be manufactured from material as specified. No other guarantees or warranty, including warranty for fitness of products for in service operating condition shall exist in connection with sale of Antec products. Heat treatment after manufacture is not included unless specified.

Refractory Anchors

AN 29B

Rotalock System Mark II Type

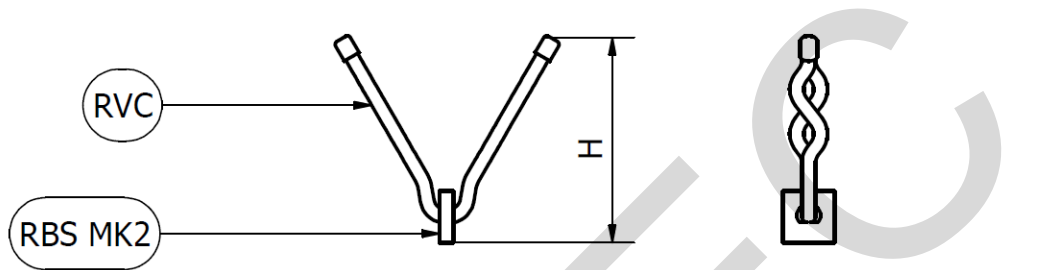

ASSEMBLED MARK 2 EXTENDED BASE ROTALOCK ANCHOR

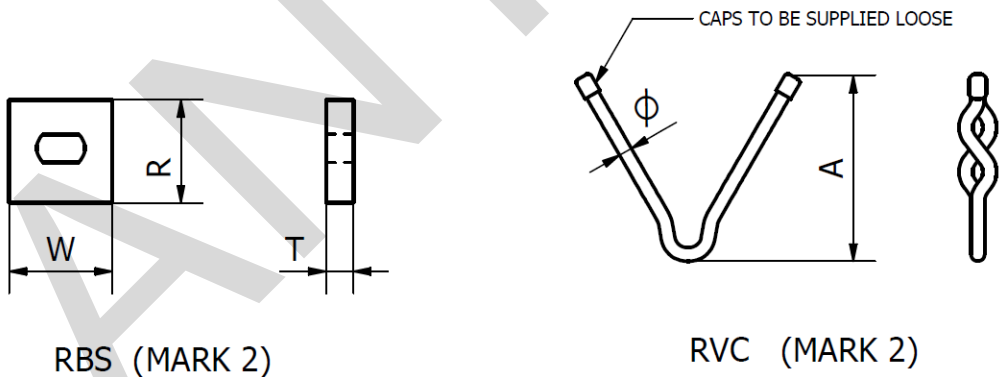

RBS (MARK 2)

RVC (MARK 2)

All items can be manufactured in various alloy steels.

RBS Bases can be manufactured in carbon steel, 304, 310, 253 MA or high nickel alloy.

Edges rounded on RBS if manufactured in carbon steel.

Tolerances:

+/- 3mm on Dimensional

+/- 3° on Angular Dimensions

Unless otherwise noted.

If $\phi = 8\text{mm}$ then $R = 30\text{mm}$

If $\phi = 10\text{mm}$ then $R = 40\text{mm}$

This drawing is the property of Antec Group Pty Ltd and is supplied on the understanding it is not to be used for any purpose, copied or communicated to any other person without written permission of the proprietor. All rights are reserved for product design concept. Antec products are guaranteed to conform within normal commercial tolerance of the applicable description furnished and to be manufactured from material as specified. No other guarantees or warranty, including warranty for fitness of products for in service operating condition shall exist in connection with sale of Antec products. Heat treatment after manufacture is not included unless specified.

Refractory Anchors

AN 29C

Rotalock System

The two piece ANTEC rotalock anchor system has unique technical, commercial and safety advantages. The rotalock anchor system consists of two separate parts:

1. A base piece (RBS) manufactured from flat bar having a precise shaped punched hole
2. A Vee anchor (RVC) manufactured in either 8mm or 10mm diameter wire

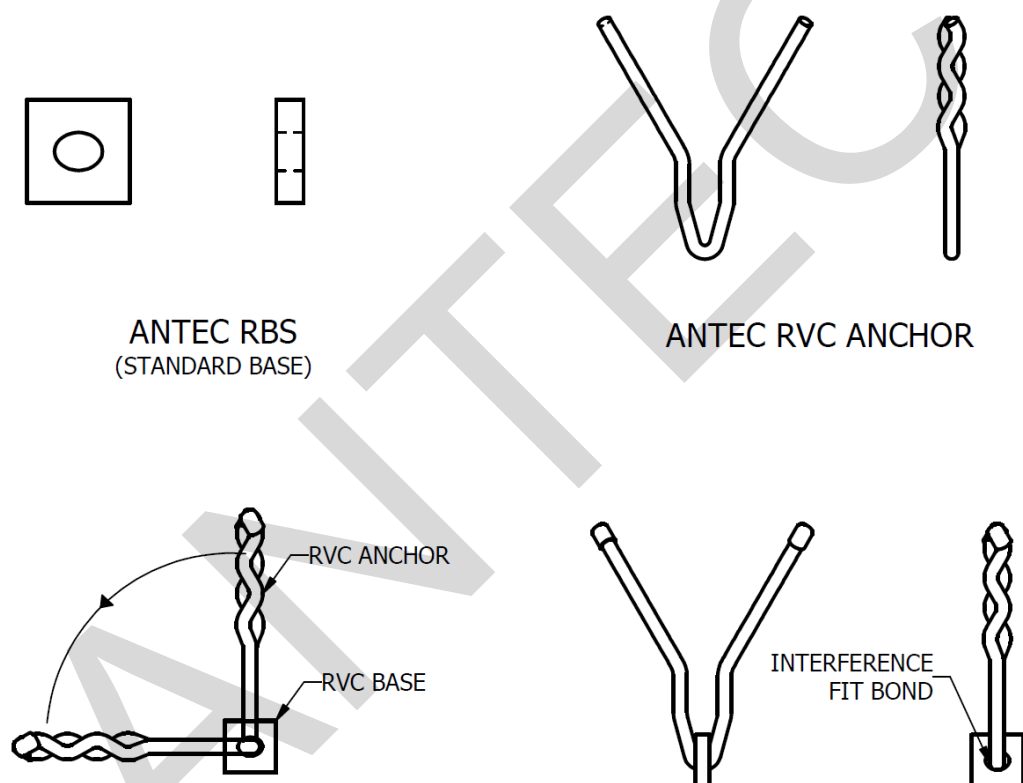

Assembly:

1. Base is welded to furnace shell
2. At the time of refractory installation the RVC anchor is horizontally threaded through the hold in the base
3. The RVC anchor is then rotated upwards to the vertical position and is held in place by interference fit

The shape of the RVC anchor and the size of the hole in the base has been calculated so that an interference fit bond occurs when the anchor top is rotated to the vertical position. There is no welding of the RVC anchor to the base. If the RVC anchor is rotated repeatedly from horizontal to vertical, the edges of the hole in the base will be increasingly deformed, reducing the tightness of the interference fit.

This drawing is the property of Antec Group Pty Ltd and is supplied on the understanding it is not to be used for any purpose, copied or communicated to any other person without written permission of the proprietor. All rights are reserved for product design concept. Antec products are guaranteed to conform within normal commercial tolerance of the applicable description furnished and to be manufactured from material as specified. No other guarantees or warranty, including warranty for fitness of products for in service operating condition shall exist in connection with sale of Antec products. Heat treatment after manufacture is not included unless specified.

Refractory Anchors

AN 29D

Rotalock Types Mark I & II

There are two variations of the rotalock systems. The both have identical principles.

ROTALOCK MARK I

The MARK I system has a larger hole in the RBS base. The larger hole allows clearance for a RVC Vee anchor with prefitted end caps or coating to be fed through the enlarged hole.

The interference fit is not as rigid or resilient to multiple rotation deformation as applies to the MARK II. The fit however, is very secure and widely use.

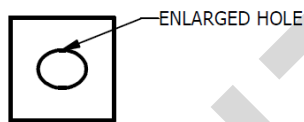

RBS MARK 1

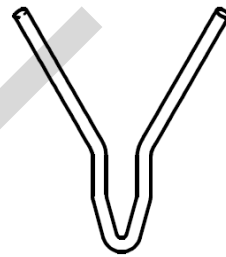

RVC MARK 1

ROTALOCK MARK II

The MARK II type has a smaller hole in the base. A coated or capped RVC anchor cannot be threaded through the hold as there is insufficient clearance. If capping is required, it can be supplied loose and fitted during installation on site.

The MARK II system is a superior and stronger interference fit, with an improved tendency to retain grip after repeated rotations of the anchor in the hole. Refer drawing AN 29B for detailed dimensions.

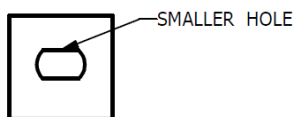

RBS MARK 2

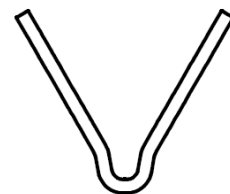

RVC MARK 2

Refractory Anchors

AN 29E

Standard Rotalock Anchor

1. Refractory linings, such as refractory linings in rotary kilns, are subject to a small degree of movement of the refractory during operations and hence the anchor will be under stress to resist any movement. Additionally, stress occurs in the refractory as it tries to move against a rigid inflexible anchor. A non flexible standard anchor can therefore cause stress in the castable contributing to cracks occurring in the refractory lining. The rotalock system was developed to tackle these problems. Whilst the RBS base is firmly and securely welded to the furnace shell, the top RVC anchor has the capacity to move. Therefore the rotalock system has flexibility and can move to reduce stress in both the anchor and the refractory. As a result, the tendency for the lining to crack can be reduced and so obtain a reduction in anchor breakage.
2. The RBS base is usually manufactured in carbon steel. When welding to a carbon steel shell, a regular carbon steel electrode is all that is required. This simplifies the welding process and reduces the cost of the weld when compared to welding of higher grade stainless steel or high nickel alloy anchors. In addition to reduced costs, regular carbon steel rods are more commonly available, particularly in remote areas.
3. The RVC anchor can be manufactured from whatever alloy the customer prefers without any concern for the cost or difficulty of welding the alloy. Because no welding is required to join the RVC anchor top to the RBS base.
4. Rotalock anchors offer trafficking and safety advantages over traditional anchors. Traditional anchors are prewelded to the furnace shell prior to the refractory installation. These prewelded anchors stand up from the furnace shell. The forest of anchors, particularly in horizontal rotary kilns, makes it difficult for traffic in the kiln and for cleaning out of rubble before the refractory is installed. It represents a safety hazard for personnel tripping over or falling on top of anchors. It is not unusual for the traditional anchors to be trodden on and flattened out. When this occurs the anchors are normally hand bent back to their original shape. The rebending significantly increases the cold working effect on the anchor with subsequent reduction of working life of such anchors. The rotalock system does not have these problems. The only item that is welded to the furnace shell is the RBS base which is only approximately 30mm high and therefore does not suffer distortion or bending from traffic in the kilns. It is easy to clean rubble out prior to refractory installation and they have a much better safety feature due to their small size.
5. Similarly for prefabricated vessels manufactured offsite , as only the 30mm high bases need to be installed it avoids a forest of anchors , simplifying transportation and erection at site without risk of damage.
6. There is the possibility that the RBS base can be reused when relining the kiln, therefore considerably saving time and expense for repairs. In this event, anchors do not need to be ground off and rewelded. Whether the base is able to be reused is entirely dependant on the condition of the base and how many times the RVC anchor has been rotated in the base, if the edges in the hole of the RBS base have been too damaged from several rotations, the fit might not be tight enough and a light tack weld could be used to add rigidity to the RVC anchor in the RBS base. In this situation the cost again would be far less than removing and rewelding new anchors to the shell.
7. Refer to drawing AN 30 for additional advantages that apply to using extended bases for multi layer linings.

Refractory Anchors

AN 30A

Extended Base Mark I Rotalock

(Refer to drawing AN 29D for explanation of Mark I type principal)

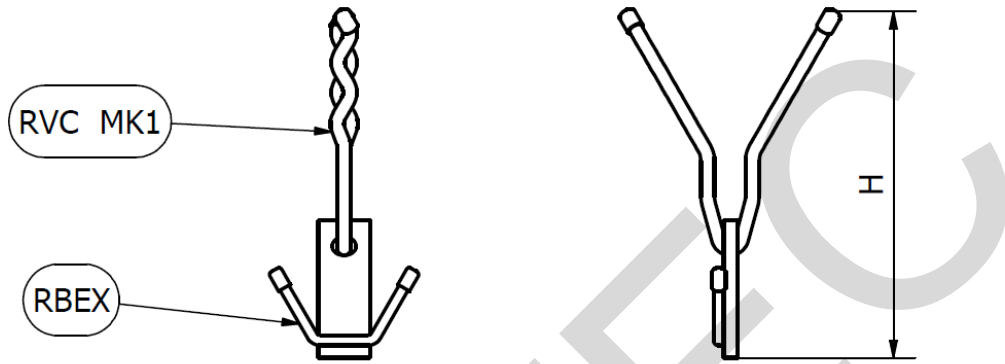

ASSEMBLED MARK 1 EXTENDED BASE ROTALOCK ANCHOR

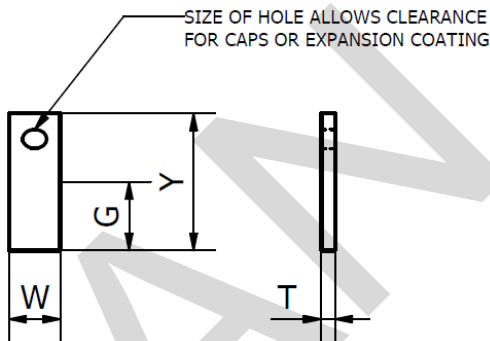

RBE (MARK 1)

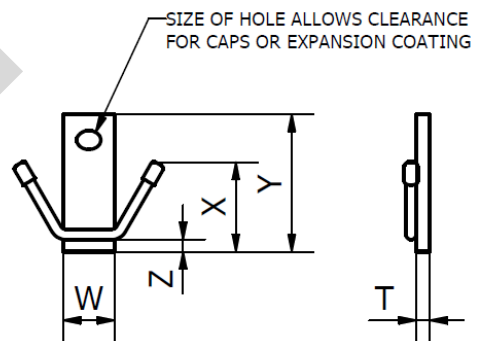

RBEX (MARK 1)

All items can be manufactured in various alloy steels. RBE & RBEX Bases can be manufactured in carbon steel, 304, 310 or high nickel alloy. Arms can be made in same alloy as the base or lower grade alloy as suitable.

Tolerances:

- +/- 3mm on Dimensional
- +/- 3° on Angular Dimensions
- Unless otherwise noted.

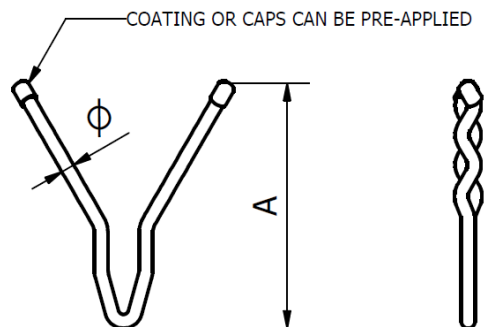

RVC (MARK 1)

This drawing is the property of Antec Group Pty Ltd and is supplied on the understanding it is not to be used for any purpose, copied or communicated to any other person without written permission of the proprietor. All rights are reserved for product design concept. Antec products are guaranteed to conform within normal commercial tolerance of the applicable description furnished and to be manufactured from material as specified. No other guarantees or warranty, including warranty for fitness of products for in service operating condition shall exist in connection with sale of Antec products. Heat treatment after manufacture is not included unless specified.

Refractory Anchors

AN 30B

Extended Base Mark II Rotalock

(Refer to drawing AN 29D for explanation of Mark I type principal)

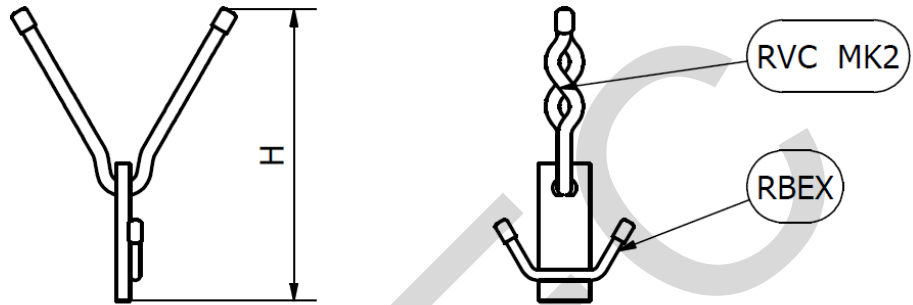

ASSEMBLED MARK 2 EXTENDED BASE ROTALOCK ANCHOR

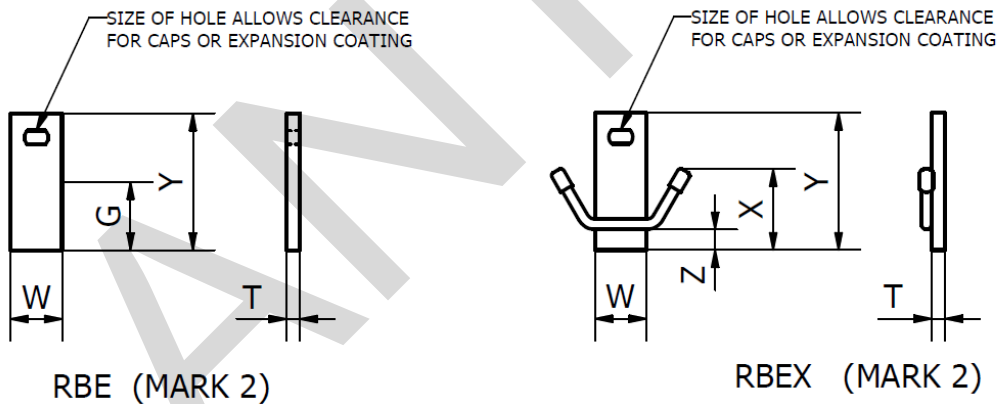

RBE (MARK 2)

RBEX (MARK 2)

All items can be manufactured in various alloy steels. RBE & RBEX Bases can be manufactured in carbon steel, 304, 310 or high nickel alloy. Arms can be made in same alloy as the base or lower grade alloy as suitable.

Tolerances:

- +/- 3mm on Dimensional
- +/- 3° on Angular Dimensions
- Unless otherwise noted.

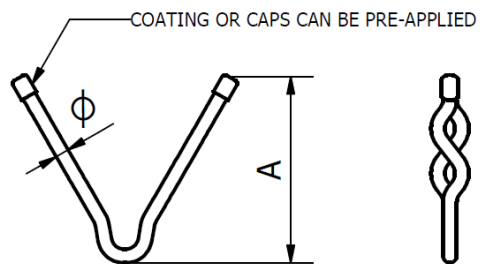

RVC (MARK 2)

This drawing is the property of Antec Group Pty Ltd and is supplied on the understanding it is not to be used for any purpose, copied or communicated to any other person without written permission of the proprietor. All rights are reserved for product design concept. Antec products are guaranteed to conform within normal commercial tolerance of the applicable description furnished and to be manufactured from material as specified. No other guarantees or warranty, including warranty for fitness of products for in service operating condition shall exist in connection with sale of Antec products. Heat treatment after manufacture is not included unless specified.

Refractory Anchors

AN 30C

Extended Base Rotalock System

An **EXTENDED BASE ROTALOCK** is when the RBS base is extended and made longer than the standard 30mm OR 40mm high RBS base. The extended base is referred to as an **RB**.

For dual layer refractory linings the extended base rotalock has proven remarkably successful over the many years of use.

The height of the standard base is increased by the same amount as the back up lining thickness, so that the extended base (RB) protrudes through the back up lining by about 30-40mm.

The RB base can have an anchor welded to it to anchor the back up lining. This anchor is pre-welded to the base; this reduces on site cost and time for welding of insulation anchorage to the furnace shell. This base with a welded anchor is referred to as an **RBX base**.

The standard RVC Vee anchor is used for the hot face.

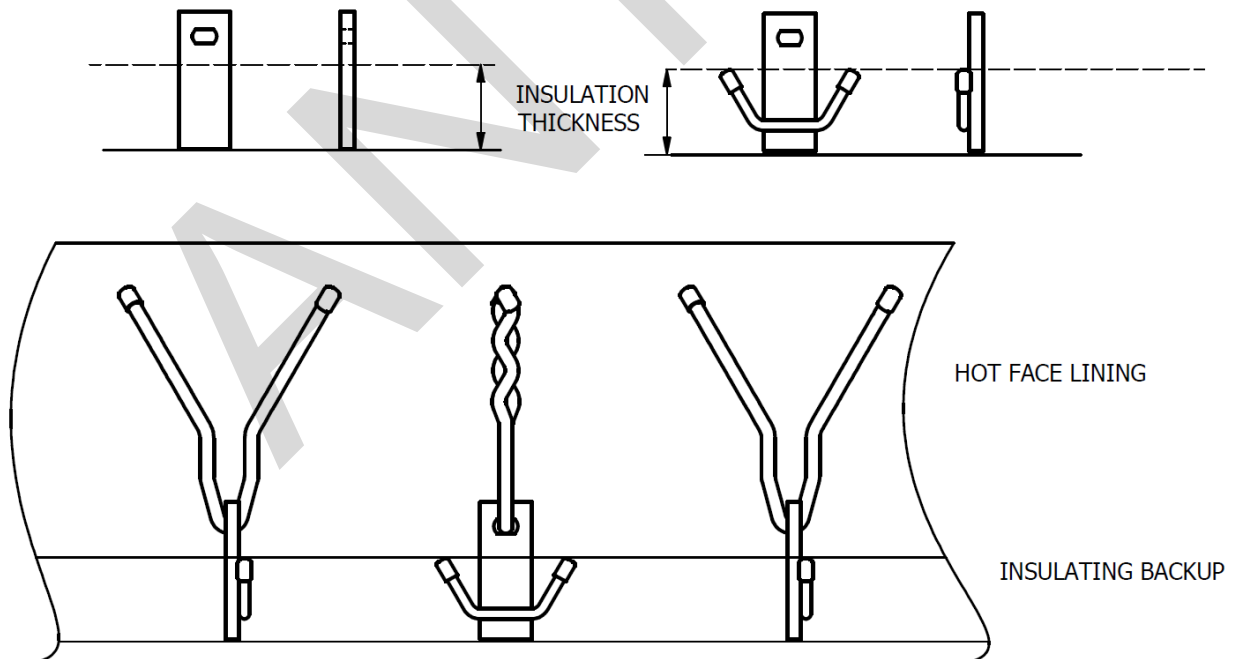

LINING CONFIGURATION

Refractory Anchors

AN 30D

Extended Base Rotalock System

The extended base rotalock system has all the advantages of the standard rotalock system as detailed on drawing AN 29 E plus the following:

1. When installing the backup insulating refractory, the extended base (RBX) is the only part of the rotalock anchor system used. The RVC anchor is only installed after the insulation is completed and when the hot face refractory is to be installed. Without the hot face anchorage in place it significantly simplifies installation of the backup lining, giving better control. The rotalock base height gives good height gauge for lining thickness control and it is easier to trim back excess thickness of insulating lining between the short base pieces extending through the back up lining.
2. Historically when conventional anchors break in service, it is most often at the interface of the back up lining and the hot face lining. Differing stresses and other reasons have shown that it is crucial to consider the strength of the anchor at the interface to help reduce failure during operation. The extended rotalock has a cross section area at the interface of 300mm² or equal to the approximate cross section areas of a 20mm diameter round bar. The extended rotalock has proven resistant to breakage at this point due to its strength and mass. No reported breakage at the interface has ever been reported over many years of usage of the system. Also, as there is no cold working or bending at the interface point, there is no acceleration of thermally induced embrittlement under operating temperatures.
3. When repairing dual layer linings anchored with Extended Bases Rotalocks, some operators only replace the hot face refractory and do not remove the insulation back up. Because the rotalock system is separable, the RVC anchor can be readily replaced whilst leaving the RBX base intact. When this applies the time saving and cost saving is of major consideration and summarised as follows:
 - a) Insulation not needed to be replaced saving on demolition cost , new insulating refractory supply and reinstallation costs.
 - b) Anchors do not have to be ground off from the shell.
 - c) The repair of the hot face can generally be carried out by the one trade, not requiring welding. (In the case of repeated rotation of the RVC anchor bases, the edges of the hole creating the interference fit will be increasingly deformed, progressively reducing the tightness. In that case a light tack weld may be needed to give the RVC sufficient strength to remain vertical. Even if this applies, the savings are still considerable.)
4. The rotalock system is supplied as two separate pieces. The RBX base may not be subjected to the same temperature and operational conditions as the RVC top. Therefore if preferred, the RBX base can be manufactured from a lower and less expensive alloy grade. This not only decreases supply cost, but could mean lower cost welding wire.
5. With a one piece conventional anchor, the entire anchor needs to be manufactured from alloy appropriate to the most demanding conditions. Stainless alloys are subject to thermally induced embrittlement when operating in a temperature zone generally between approximately 600°C and 900°C. If a furnace temperature is say 1100°C, due to the temperature gradient through the lining thickness, some section along the length of the anchor will be exposed to this undesirable embrittling effect of this temperature zone. Therefore because the rotalock is a two piece system, it allows the customer a choice to use a higher and more effective grade in the part of the rotalock anchor system enabling it to operate in this temperature zone.

Refractory Anchors

AN 30E

RBX Base Mark I & II

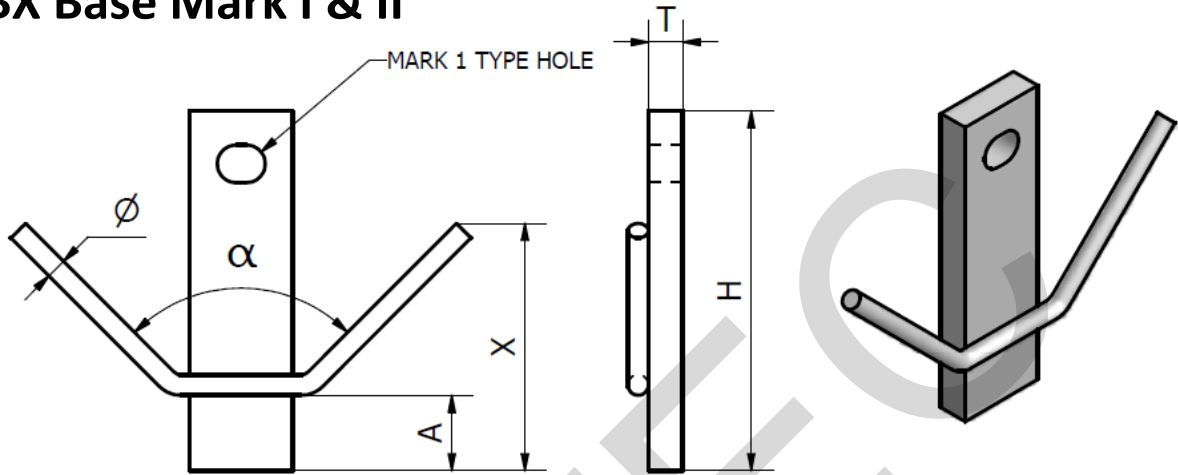

MARK 1

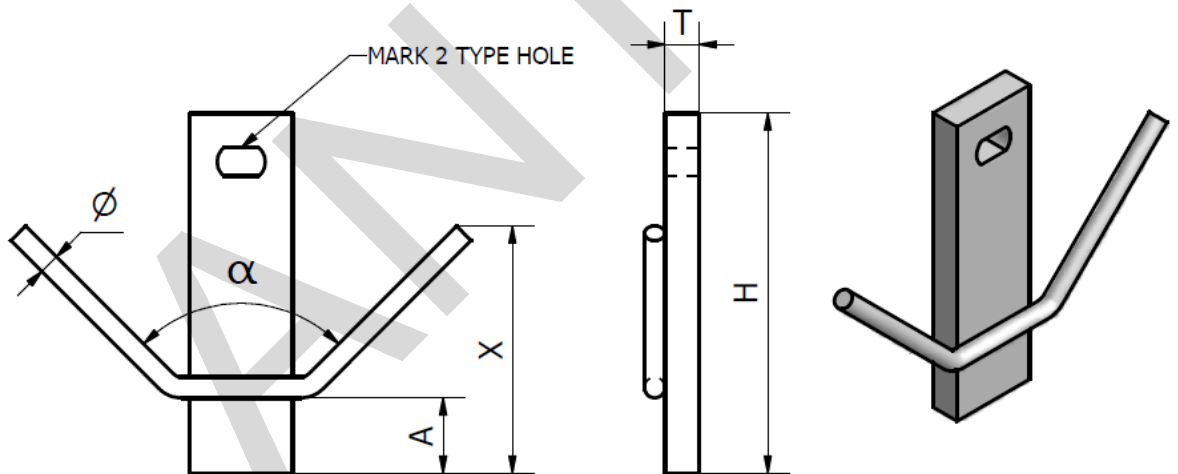

MARK 2

All items can be manufactured in various alloy steels.

Note: Caps can be supplied if requested. The angle alpha must be specified when ordering. For quoting purposes, please specify X (Backup lining thickness) and H (Full base height = X + 30mm).

Tolerances:

+/- 3mm on Dimensional

+/- 3° on Angular Dimensions

Unless otherwise noted.

This drawing is the property of Antec Group Pty Ltd and is supplied on the understanding it is not to be used for any purpose, copied or communicated to any other person without written permission of the proprietor. All rights are reserved for product design concept. Antec products are guaranteed to conform within normal commercial tolerance of the applicable description furnished and to be manufactured from material as specified. No other guarantees or warranty, including warranty for fitness of products for in service operating condition shall exist in connection with sale of Antec products. Heat treatment after manufacture is not included unless specified.

Refractory Anchors

AN 30F

RBS/RB Mark I

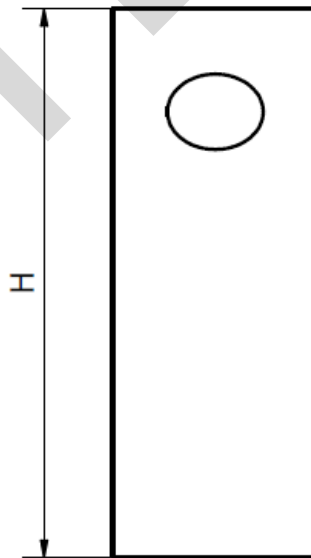
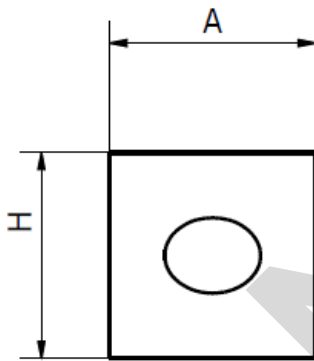
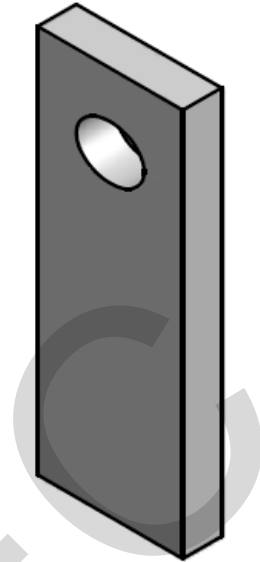
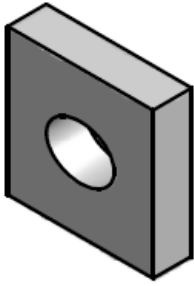

RBS MK-1

RB MK-1

All items can be manufactured in various alloy steels.
Edges rounded on RBS if manufactured in carbon steel.

Tolerances:

- +/- 3mm on Dimensional
- +/- 3° on Angular Dimensions
- Unless otherwise noted.

This drawing is the property of Antec Group Pty Ltd and is supplied on the understanding it is not to be used for any purpose, copied or communicated to any other person without written permission of the proprietor. All rights are reserved for product design concept. Antec products are guaranteed to conform within normal commercial tolerance of the applicable description furnished and to be manufactured from material as specified. No other guarantees or warranty, including warranty for fitness of products for in service operating condition shall exist in connection with sale of Antec products. Heat treatment after manufacture is not included unless specified.

Refractory Anchors

AN 30G

RBS/RB Mark II

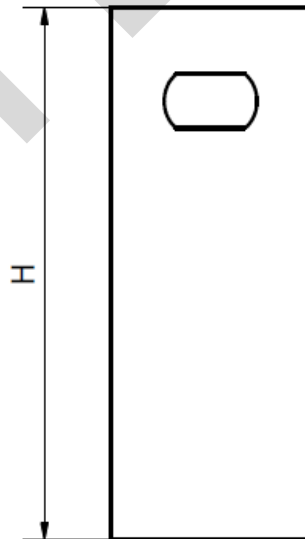
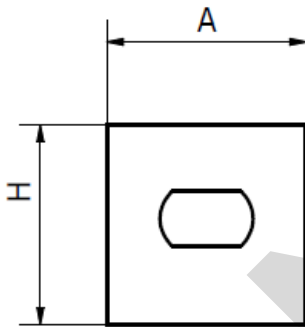
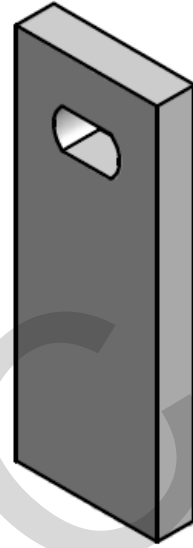
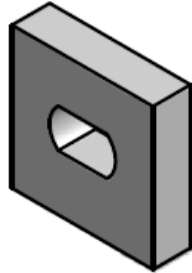

RBS MK-2

RB MK-2

All items can be manufactured in various alloy steels.
Edges rounded on RBS if manufactured in carbon steel.

Tolerances:

- +/- 3mm on Dimensional
- +/- 3° on Angular Dimensions
- Unless otherwise noted.

This drawing is the property of Antec Group Pty Ltd and is supplied on the understanding it is not to be used for any purpose, copied or communicated to any other person without written permission of the proprietor. All rights are reserved for product design concept. Antec products are guaranteed to conform within normal commercial tolerance of the applicable description furnished and to be manufactured from material as specified. No other guarantees or warranty, including warranty for fitness of products for in service operating condition shall exist in connection with sale of Antec products. Heat treatment after manufacture is not included unless specified.

Refractory Anchors

AN 31

FC Anchor

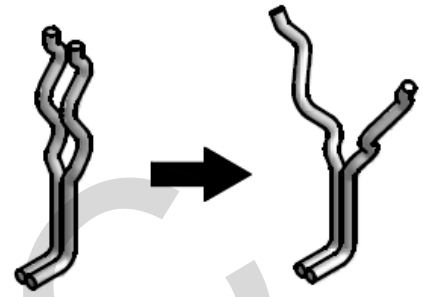
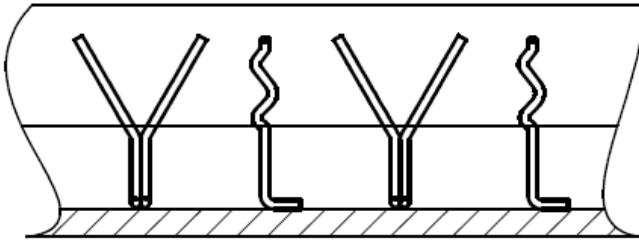

PURCHASED POSITION

INSTALLED POSITION

FIBERCAST ANCHORS (FC) SUPPLIED WITH TYNES PARALLEL;
AFTER INSULATION LINING IS INSTALLED, THE TYNES ARE BENT
OUT TO FORM A VEE AND THE HOT FACE REFRACTORY IS
INSTALLED.

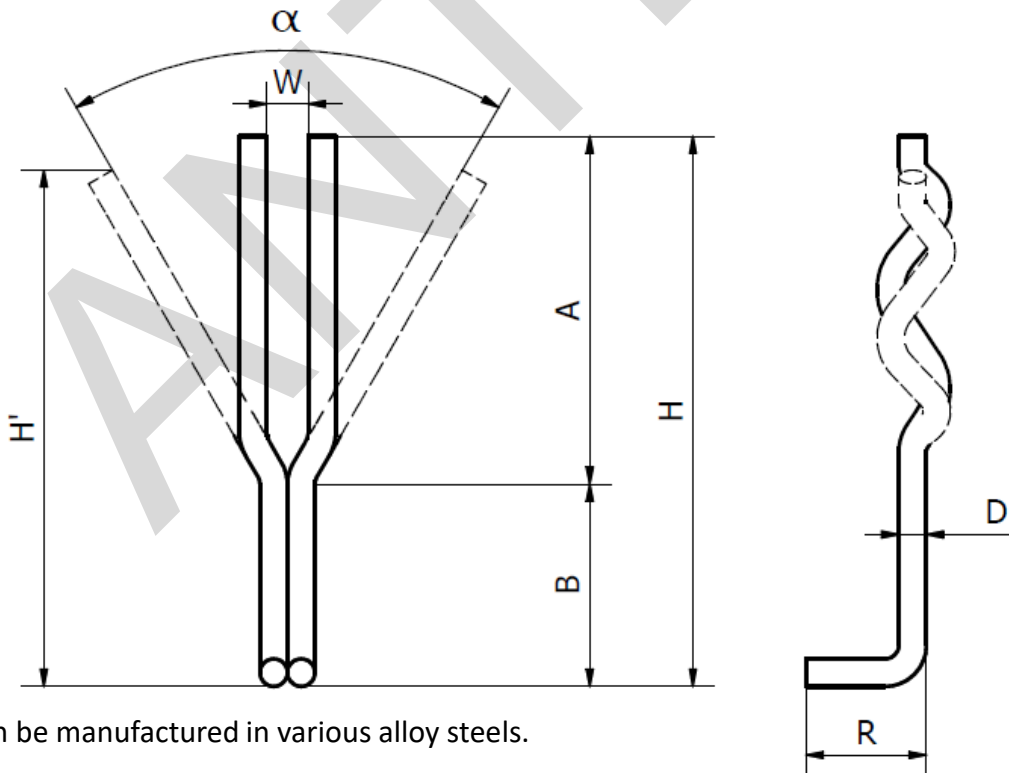

All items can be manufactured in various alloy steels.

Tolerances:

+/- 3mm on Dimensional

+/- 3° on Angular Dimensions

Unless otherwise noted.

This drawing is the property of Antec Group Pty Ltd and is supplied on the understanding it is not to be used for any purpose, copied or communicated to any other person without written permission of the proprietor. All rights are reserved for product design concept. Antec products are guaranteed to conform within normal commercial tolerance of the applicable description furnished and to be manufactured from material as specified. No other guarantees or warranty, including warranty for fitness of products for in service operating condition shall exist in connection with sale of Antec products. Heat treatment after manufacture is not included unless specified.

Refractory Anchors

AN 32

HP Anchor

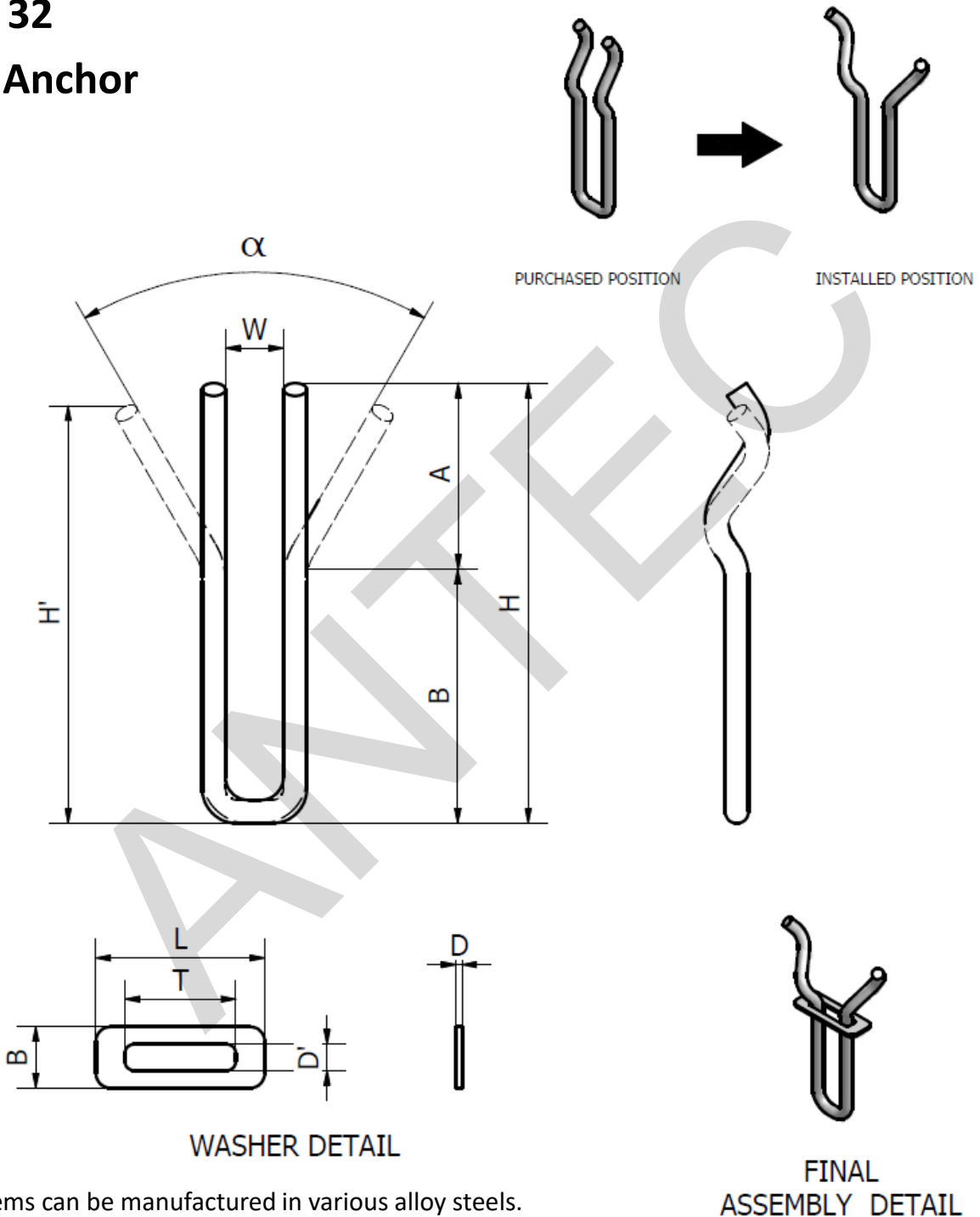

All items can be manufactured in various alloy steels.

Tolerances:

+/- 3mm on Dimensional

+/- 3° on Angular Dimensions

Unless otherwise noted.

This drawing is the property of Antec Group Pty Ltd and is supplied on the understanding it is not to be used for any purpose, copied or communicated to any other person without written permission of the proprietor. All rights are reserved for product design concept. Antec products are guaranteed to conform within normal commercial tolerance of the applicable description furnished and to be manufactured from material as specified. No other guarantees or warranty, including warranty for fitness of products for in service operating condition shall exist in connection with sale of Antec products. Heat treatment after manufacture is not included unless specified.

Refractory Anchors

AN 33

WNL Anchor

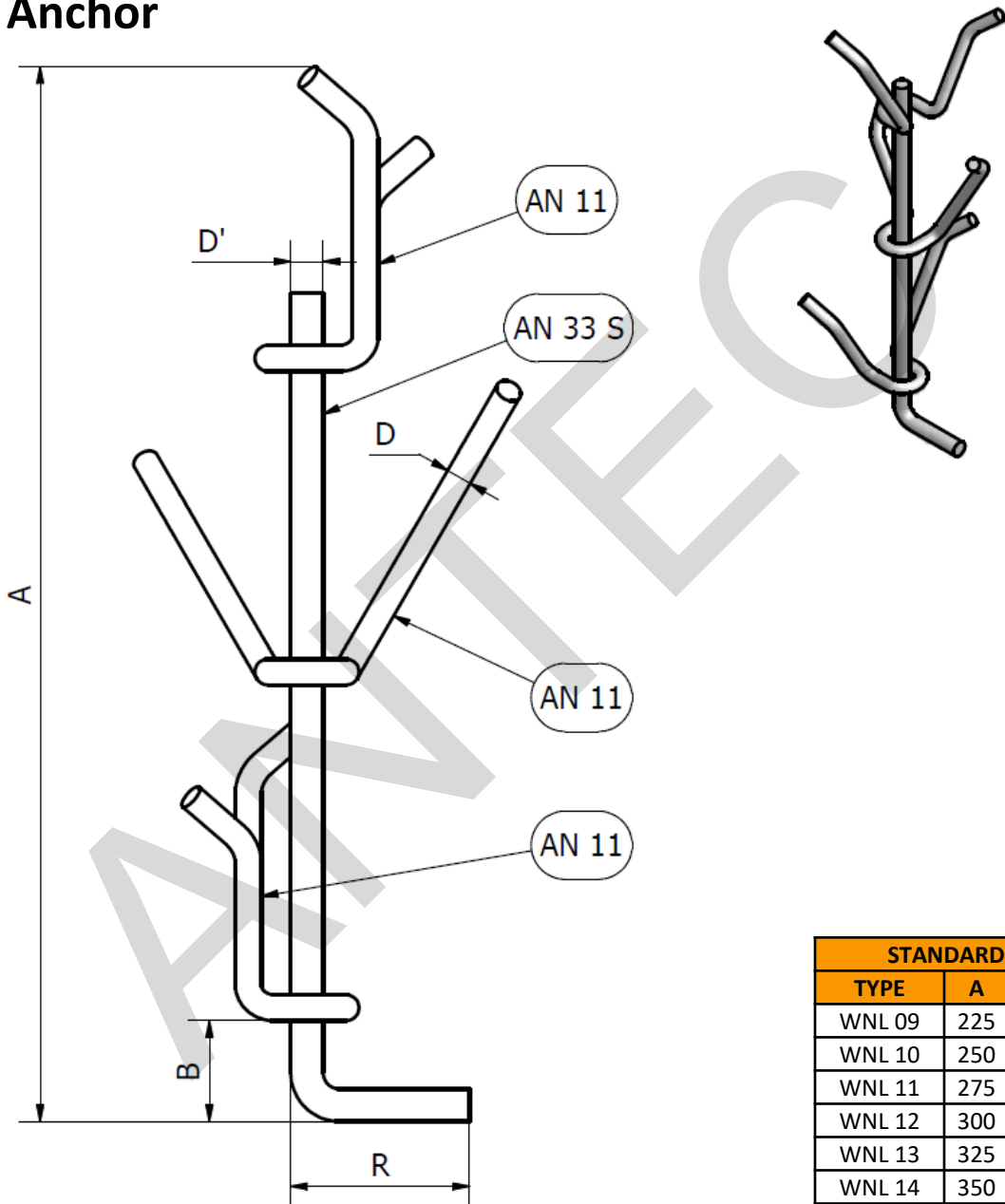

All items can be manufactured in various alloy steels.
All welded anchor height will be evenly spaced unless specified.

Tolerances:

- +/- 3mm on Dimensional
- +/- 3° on Angular Dimensions
- Unless otherwise noted.

STANDARD SIZES		
TYPE	A	# of WB 43
WNL 09	225	2
WNL 10	250	2
WNL 11	275	2
WNL 12	300	2
WNL 13	325	3
WNL 14	350	3
WNL 15	375	3
WNL 16	400	3
WNL 17	425	4
WNL 18	450	4
WNL 19	475	4
WNL 20	500	4
WNL 21	525	5

This drawing is the property of Antec Group Pty Ltd and is supplied on the understanding it is not to be used for any purpose, copied or communicated to any other person without written permission of the proprietor. All rights are reserved for product design concept. Antec products are guaranteed to conform within normal commercial tolerance of the applicable description furnished and to be manufactured from material as specified. No other guarantees or warranty, including warranty for fitness of products for in service operating condition shall exist in connection with sale of Antec products. Heat treatment after manufacture is not included unless specified.

Refractory Anchors

AN 33A

VCXT Anchor

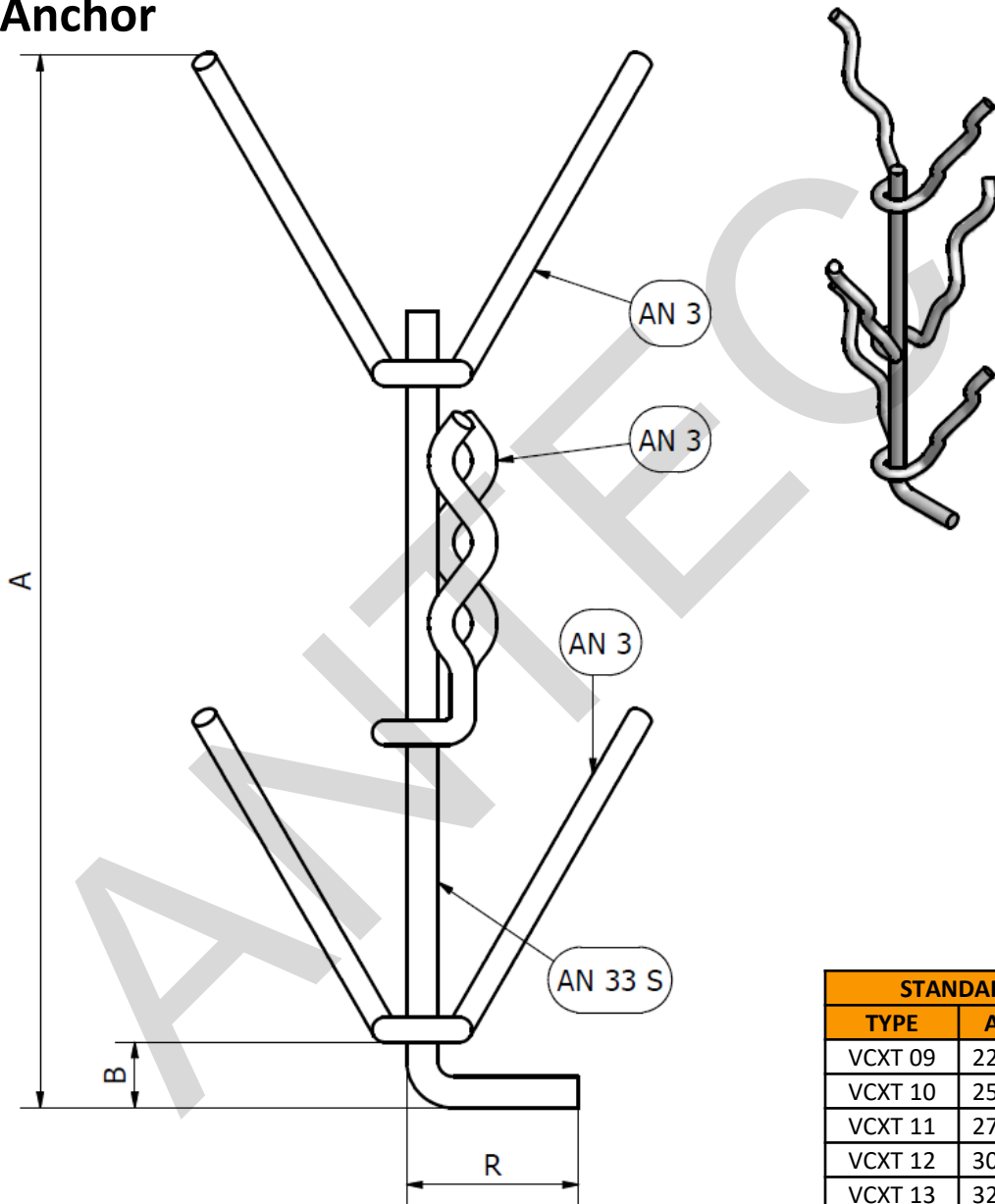

All items can be manufactured in various alloy steels.
All welded anchor height will be evenly spaced unless specified.

Tolerances:

- +/- 3mm on Dimensional
- +/- 3° on Angular Dimensions
- Unless otherwise noted

Corrugation as drawn is diagrammatic only.

STANDARD SIZES		
TYPE	A	# of WB 43
VCXT 09	225	2
VCXT 10	250	2
VCXT 11	275	2
VCXT 12	300	2
VCXT 13	325	3
VCXT 14	350	3
VCXT 15	375	3
VCXT 16	400	3
VCXT 17	425	4
VCXT 18	450	4
VCXT 19	475	4
VCXT 20	500	4
VCXT 21	525	5

This drawing is the property of Antec Group Pty Ltd and is supplied on the understanding it is not to be used for any purpose, copied or communicated to any other person without written permission of the proprietor. All rights are reserved for product design concept. Antec products are guaranteed to conform within normal commercial tolerance of the applicable description furnished and to be manufactured from material as specified. No other guarantees or warranty, including warranty for fitness of products for in service operating condition shall exist in connection with sale of Antec products. Heat treatment after manufacture is not included unless specified.

Refractory Anchors

AN 33B

Octopus Anchor

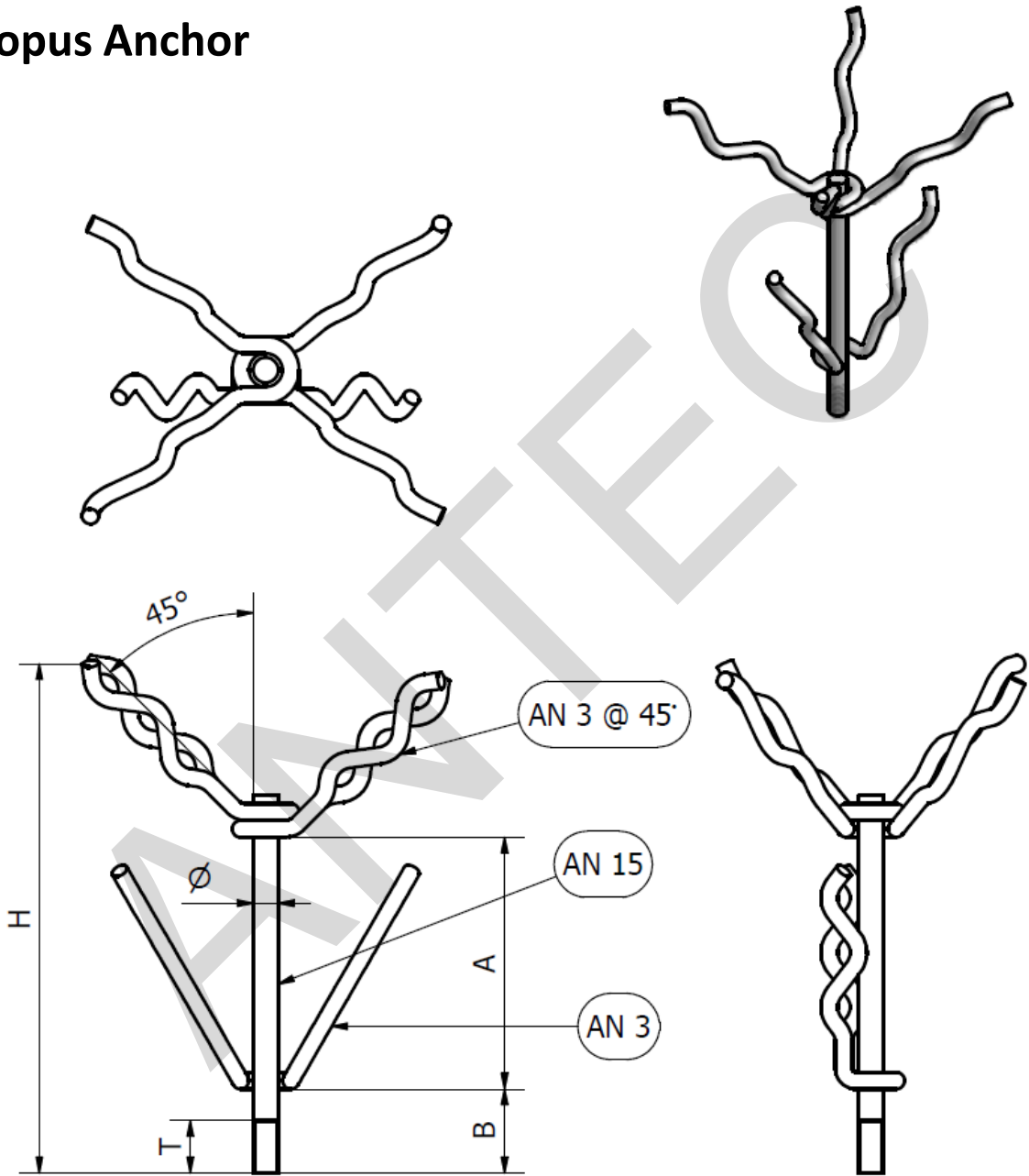

All items can be manufactured in various alloy steels.

Tolerances:

+/- 3mm on Dimensional

+/- 3° on Angular Dimensions

Unless otherwise noted

Corrugation as drawn is diagrammatic only.

This drawing is the property of Antec Group Pty Ltd and is supplied on the understanding it is not to be used for any purpose, copied or communicated to any other person without written permission of the proprietor. All rights are reserved for product design concept. Antec products are guaranteed to conform within normal commercial tolerance of the applicable description furnished and to be manufactured from material as specified. No other guarantees or warranty, including warranty for fitness of products for in service operating condition shall exist in connection with sale of Antec products. Heat treatment after manufacture is not included unless specified.

Refractory Anchors

AN 34

Wall Seat Anchor

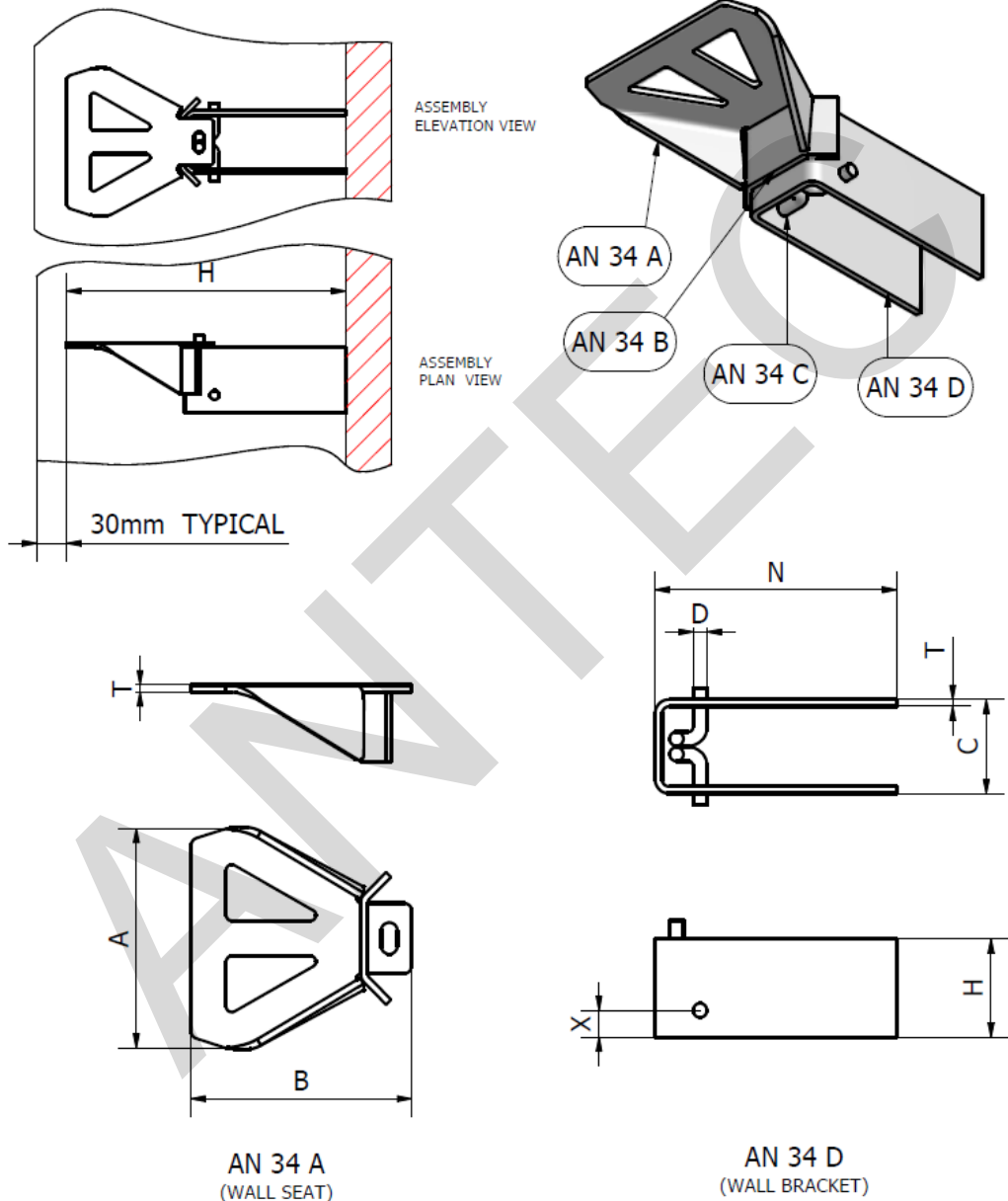

All items can be manufactured in various alloy steels.

Standard Size of dimension B = 157mm

Tolerances:

+/- 3mm on Dimensional

+/- 3° on Angular Dimensions

Unless otherwise noted.

This drawing is the property of Antec Group Pty Ltd and is supplied on the understanding it is not to be used for any purpose, copied or communicated to any other person without written permission of the proprietor. All rights are reserved for product design concept. Antec products are guaranteed to conform within normal commercial tolerance of the applicable description furnished and to be manufactured from material as specified. No other guarantees or warranty, including warranty for fitness of products for in service operating condition shall exist in connection with sale of Antec products. Heat treatment after manufacture is not included unless specified.

Refractory Anchors

AN 35A

PV Anchor (with Z bar)

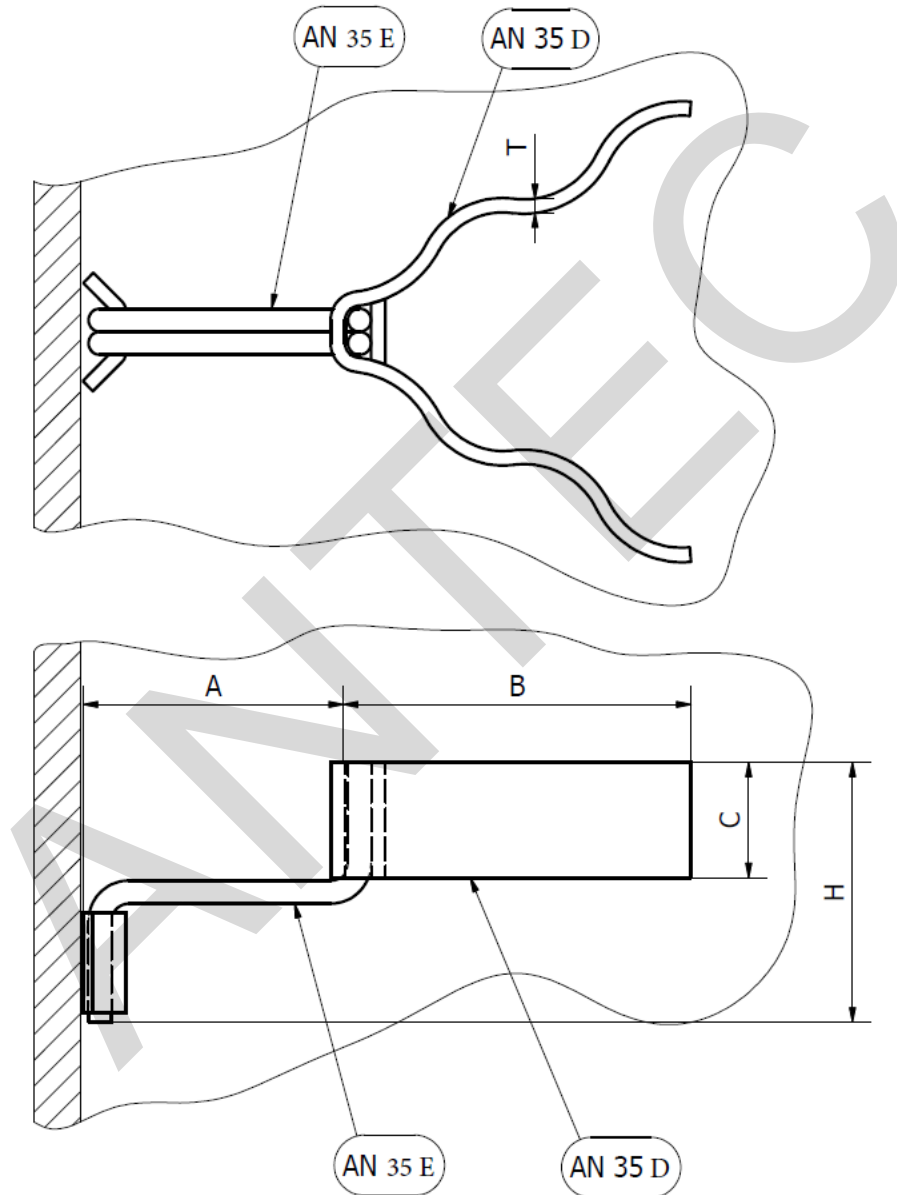

All items can be manufactured in various alloy steels.

Tolerances:

+/- 3mm on Dimensional

+/- 3° on Angular Dimensions

Unless otherwise noted

Corrugation as drawn is diagrammatic only.

This drawing is the property of Antec Group Pty Ltd and is supplied on the understanding it is not to be used for any purpose, copied or communicated to any other person without written permission of the proprietor. All rights are reserved for product design concept. Antec products are guaranteed to conform within normal commercial tolerance of the applicable description furnished and to be manufactured from material as specified. No other guarantees or warranty, including warranty for fitness of products for in service operating condition shall exist in connection with sale of Antec products. Heat treatment after manufacture is not included unless specified.

Refractory Anchors

AN 35B

PV Anchor (with ZBM bar)

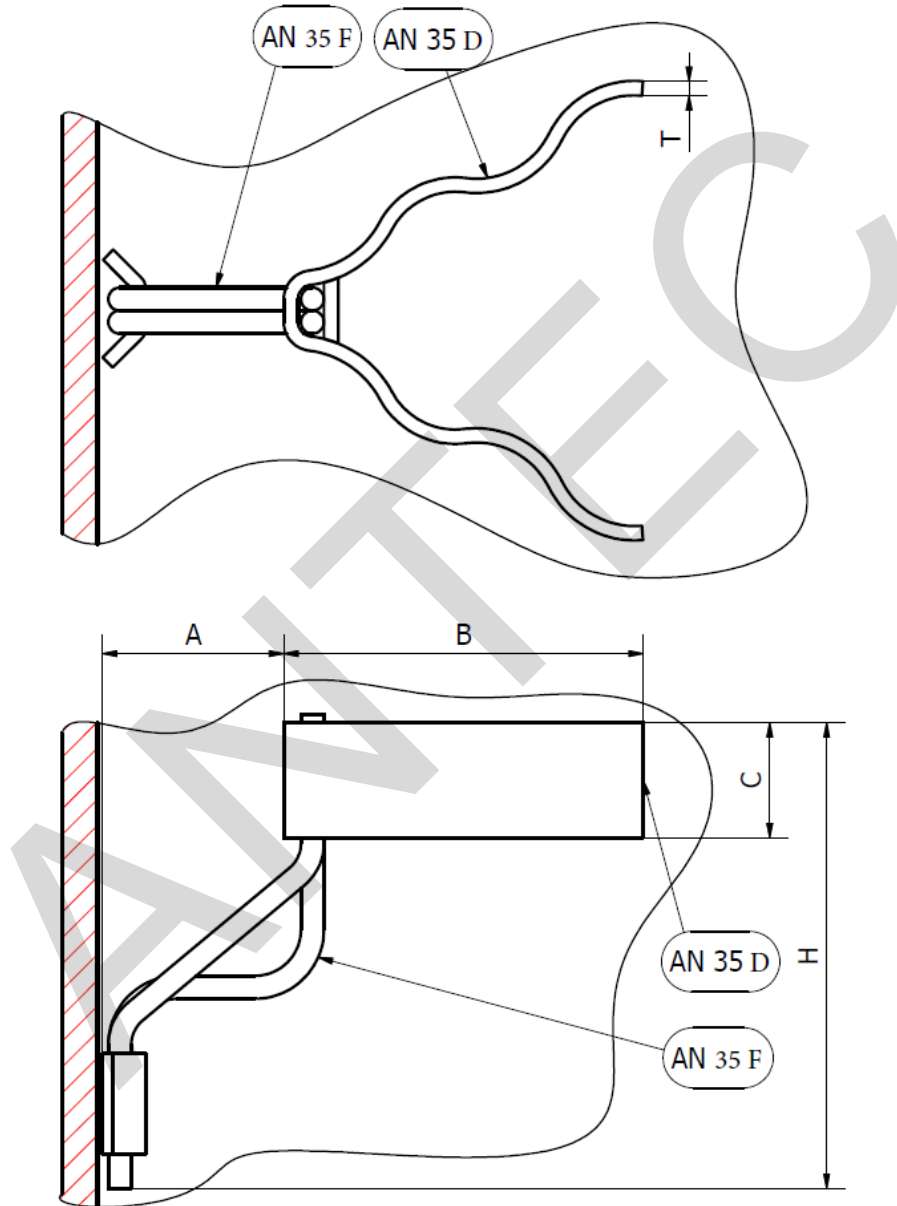

All items can be manufactured in various alloy steels.

Tolerances:

+/- 3mm on Dimensional

+/- 3° on Angular Dimensions

Unless otherwise noted

Corrugation as drawn is diagrammatic only.

This drawing is the property of Antec Group Pty Ltd and is supplied on the understanding it is not to be used for any purpose, copied or communicated to any other person without written permission of the proprietor. All rights are reserved for product design concept. Antec products are guaranteed to conform within normal commercial tolerance of the applicable description furnished and to be manufactured from material as specified. No other guarantees or warranty, including warranty for fitness of products for in service operating condition shall exist in connection with sale of Antec products. Heat treatment after manufacture is not included unless specified.

Refractory Anchors

AN 35C

PV Anchor (with AN 70 Hook Anchor)

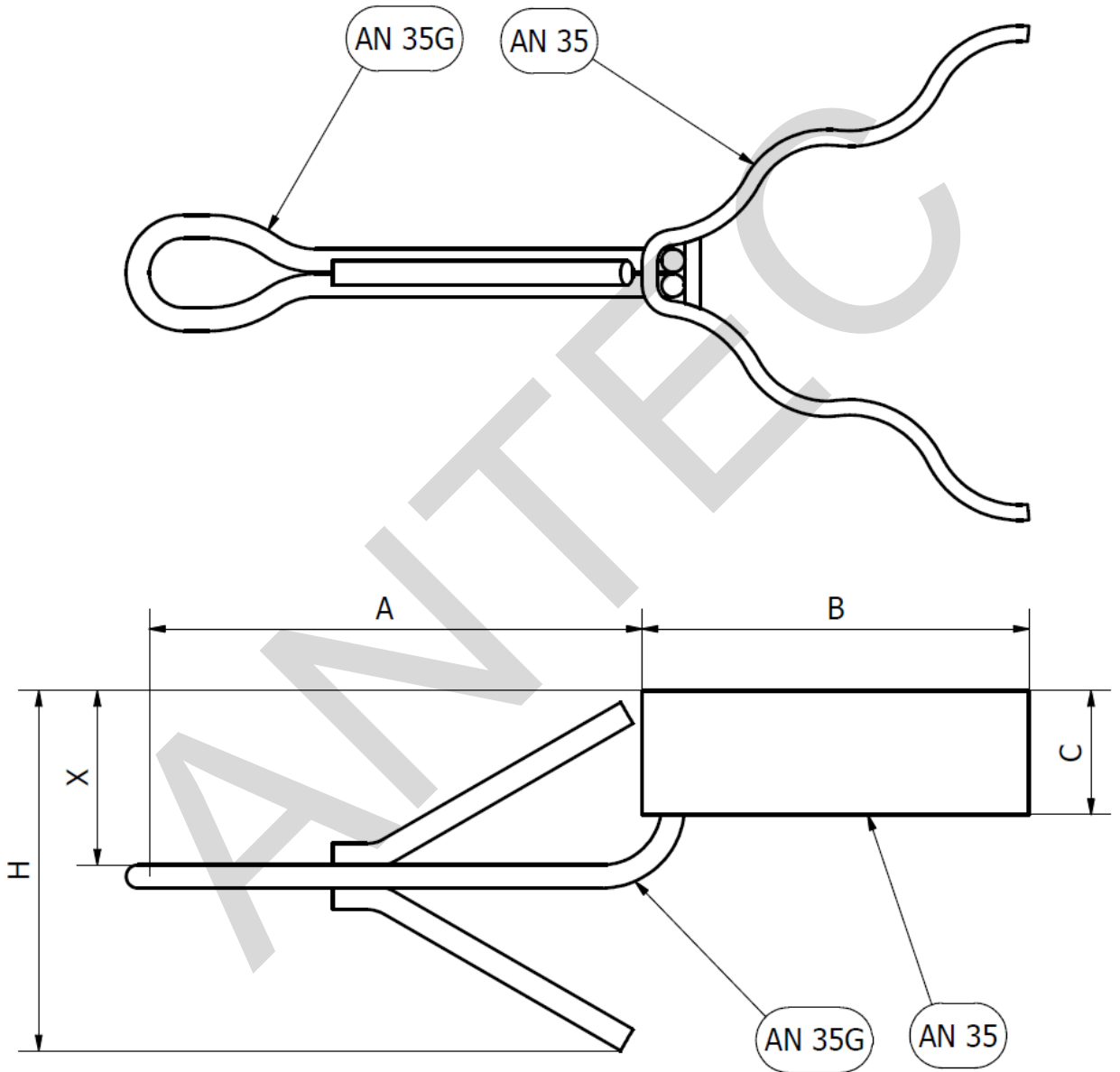

All items can be manufactured in various alloy steels.

Tolerances:

+/- 3mm on Dimensional

+/- 3° on Angular Dimensions

Unless otherwise noted

Corrugation as drawn is diagrammatic only.

This drawing is the property of Antec Group Pty Ltd and is supplied on the understanding it is not to be used for any purpose, copied or communicated to any other person without written permission of the proprietor. All rights are reserved for product design concept. Antec products are guaranteed to conform within normal commercial tolerance of the applicable description furnished and to be manufactured from material as specified. No other guarantees or warranty, including warranty for fitness of products for in service operating condition shall exist in connection with sale of Antec products. Heat treatment after manufacture is not included unless specified.

Refractory Anchors

AN 35D

PV Anchor

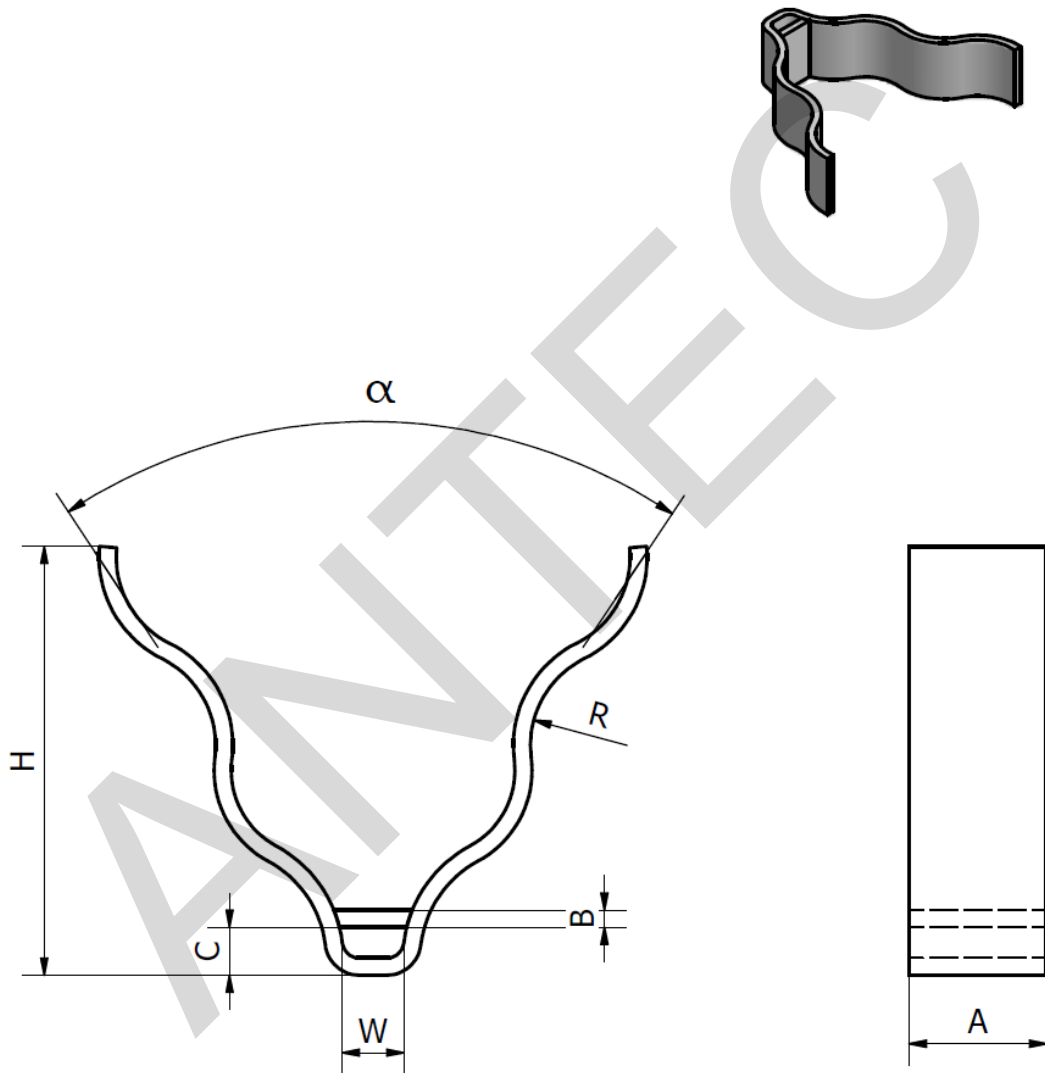

All items can be manufactured in various alloy steels.

Tolerances:

+/- 3mm on Dimensional

+/- 3° on Angular Dimensions

Unless otherwise noted

Corrugation as drawn is diagrammatic only.

This drawing is the property of Antec Group Pty Ltd and is supplied on the understanding it is not to be used for any purpose, copied or communicated to any other person without written permission of the proprietor. All rights are reserved for product design concept. Antec products are guaranteed to conform within normal commercial tolerance of the applicable description furnished and to be manufactured from material as specified. No other guarantees or warranty, including warranty for fitness of products for in service operating condition shall exist in connection with sale of Antec products. Heat treatment after manufacture is not included unless specified.

Refractory Anchors

AN 35E

Z Bar

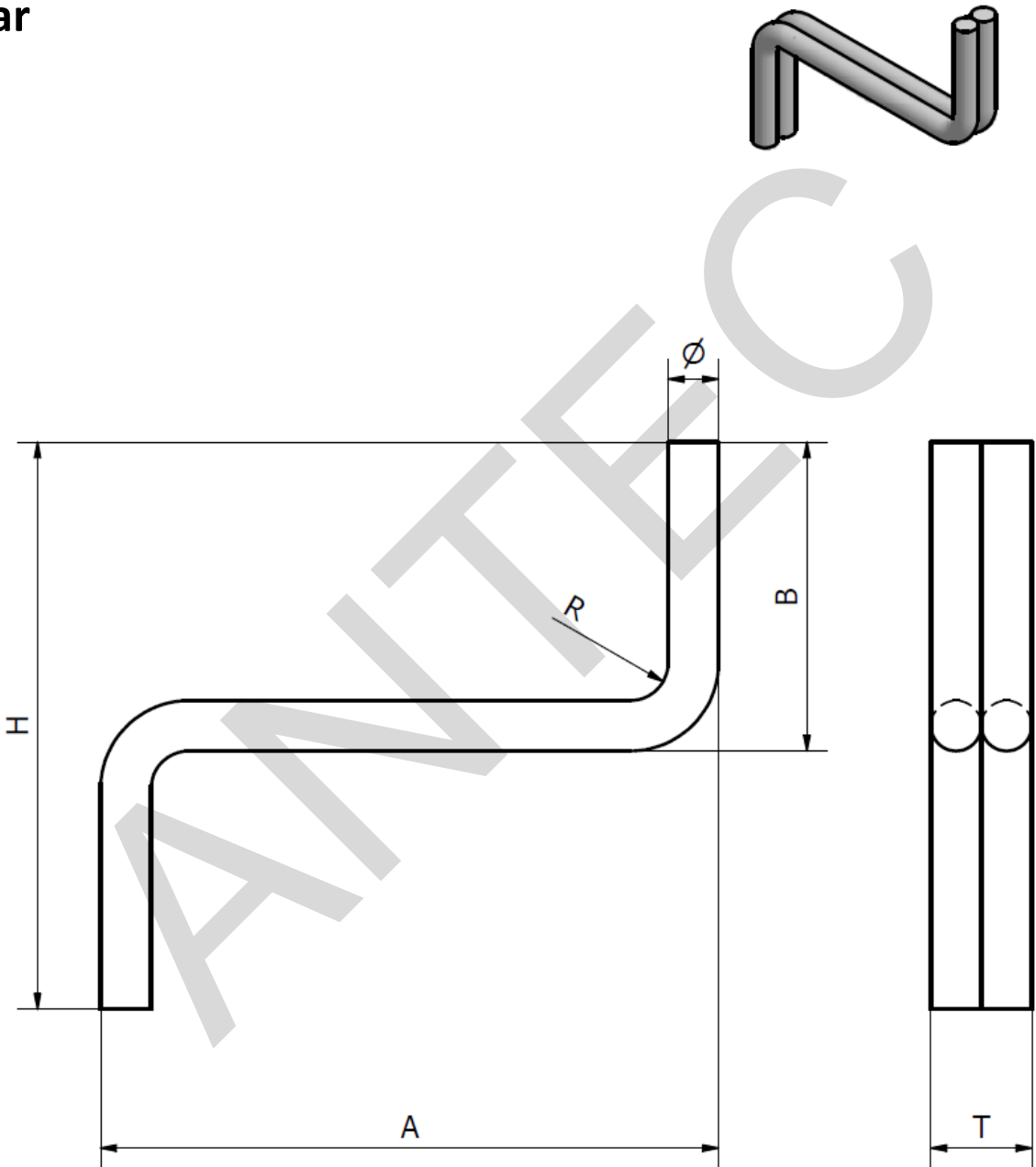

All items can be manufactured in various alloy steels.

Tolerances:

+/- 3mm on Dimensional

+/- 3° on Angular Dimensions

Unless otherwise noted.

This drawing is the property of Antec Group Pty Ltd and is supplied on the understanding it is not to be used for any purpose, copied or communicated to any other person without written permission of the proprietor. All rights are reserved for product design concept. Antec products are guaranteed to conform within normal commercial tolerance of the applicable description furnished and to be manufactured from material as specified. No other guarantees or warranty, including warranty for fitness of products for in service operating condition shall exist in connection with sale of Antec products. Heat treatment after manufacture is not included unless specified.

Refractory Anchors

AN 35F

ZBM Bar

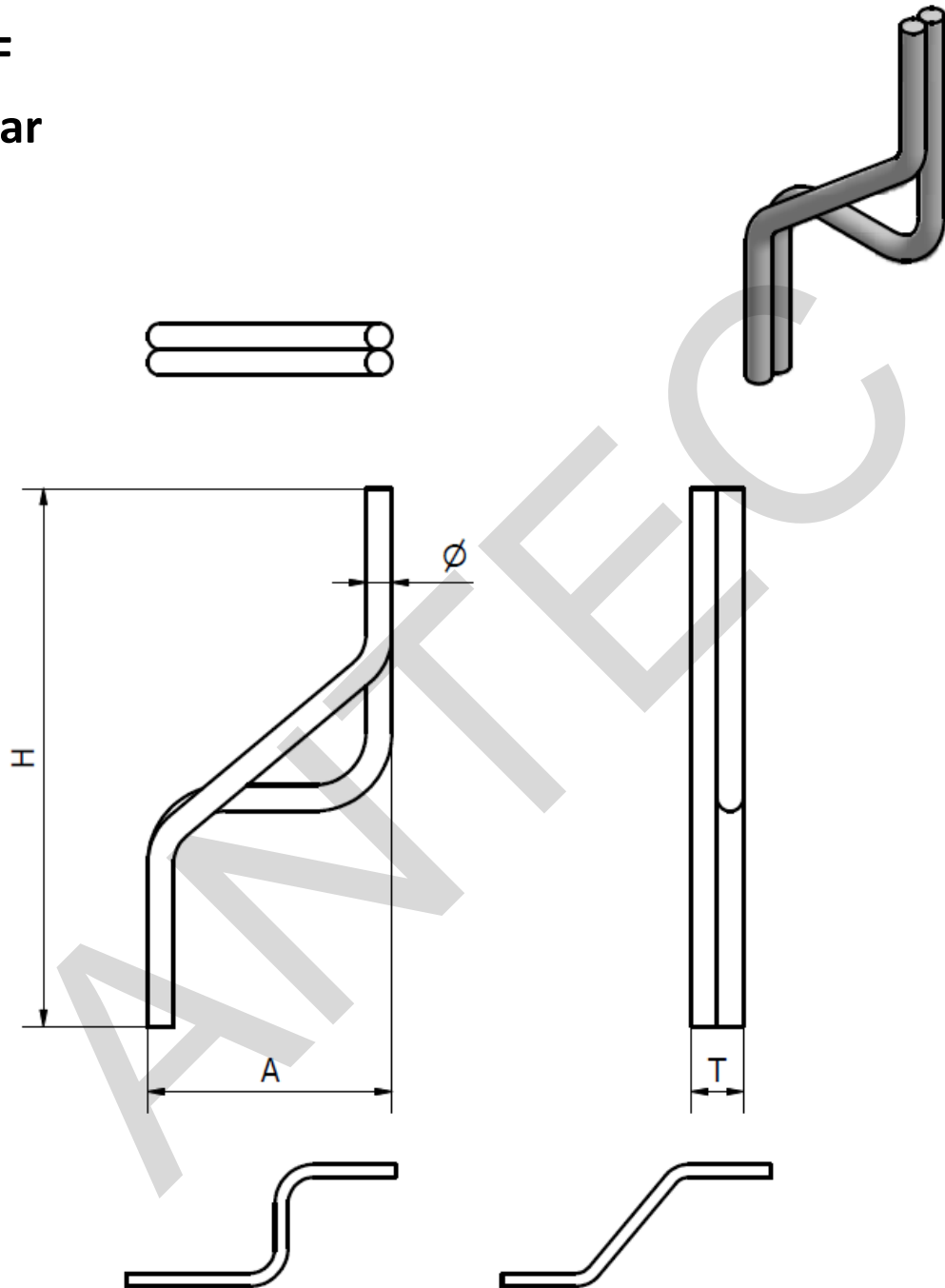

INDIVIDUAL COMPONENTS

All items can be manufactured in various alloy steels.

Tolerances:

+/- 3mm on Dimensional

+/- 3° on Angular Dimensions

Unless otherwise noted.

This drawing is the property of Antec Group Pty Ltd and is supplied on the understanding it is not to be used for any purpose, copied or communicated to any other person without written permission of the proprietor. All rights are reserved for product design concept. Antec products are guaranteed to conform within normal commercial tolerance of the applicable description furnished and to be manufactured from material as specified. No other guarantees or warranty, including warranty for fitness of products for in service operating condition shall exist in connection with sale of Antec products. Heat treatment after manufacture is not included unless specified.

Refractory Anchors

AN 35G

Anchor Hook

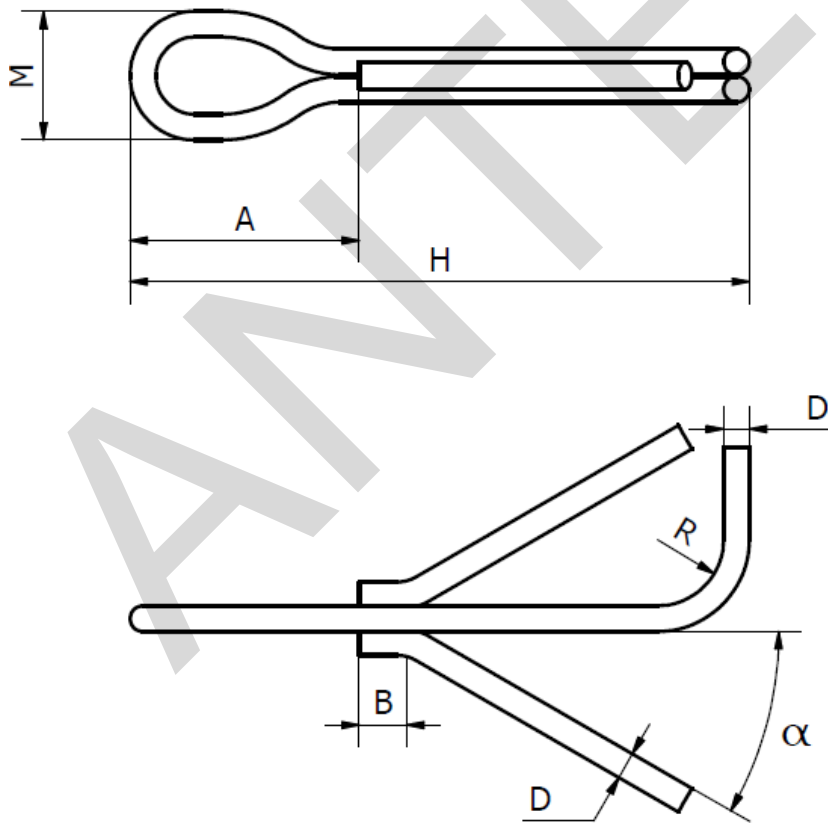
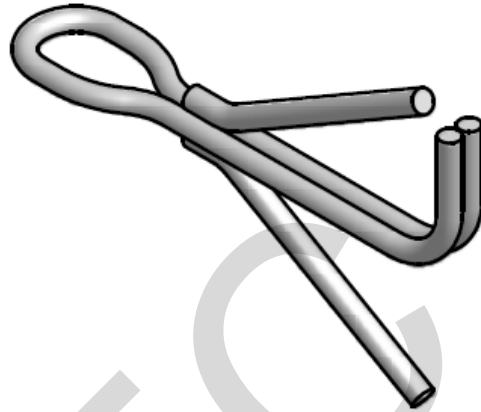

All items can be manufactured in various alloy steels.

Tolerances:

+/- 3mm on Dimensional

+/- 3° on Angular Dimensions

Unless otherwise noted.

This drawing is the property of Antec Group Pty Ltd and is supplied on the understanding it is not to be used for any purpose, copied or communicated to any other person without written permission of the proprietor. All rights are reserved for product design concept. Antec products are guaranteed to conform within normal commercial tolerance of the applicable description furnished and to be manufactured from material as specified. No other guarantees or warranty, including warranty for fitness of products for in service operating condition shall exist in connection with sale of Antec products. Heat treatment after manufacture is not included unless specified.

Refractory Anchors

AN 36

C Clip Type 1

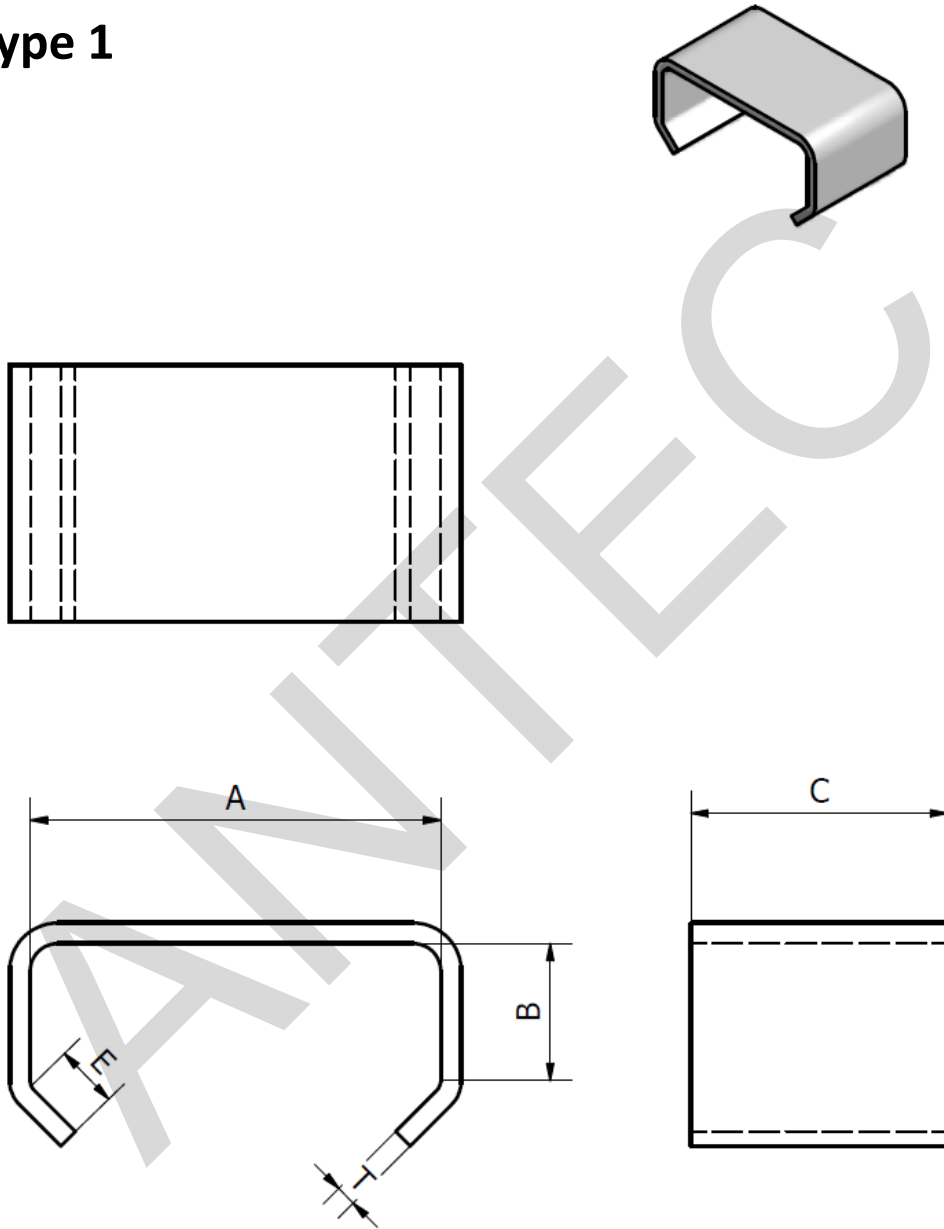

All items can be manufactured in various alloy steels.

Note: Anchor brick type to be specified at time of order.

Tolerances:

+/- 3mm on Dimensional

+/- 3° on Angular Dimensions

Unless otherwise noted.

T = 6mm TYP.

This drawing is the property of Antec Group Pty Ltd and is supplied on the understanding it is not to be used for any purpose, copied or communicated to any other person without written permission of the proprietor. All rights are reserved for product design concept. Antec products are guaranteed to conform within normal commercial tolerance of the applicable description furnished and to be manufactured from material as specified. No other guarantees or warranty, including warranty for fitness of products for in service operating condition shall exist in connection with sale of Antec products. Heat treatment after manufacture is not included unless specified.

Refractory Anchors

AN 37

C Clip Type 2

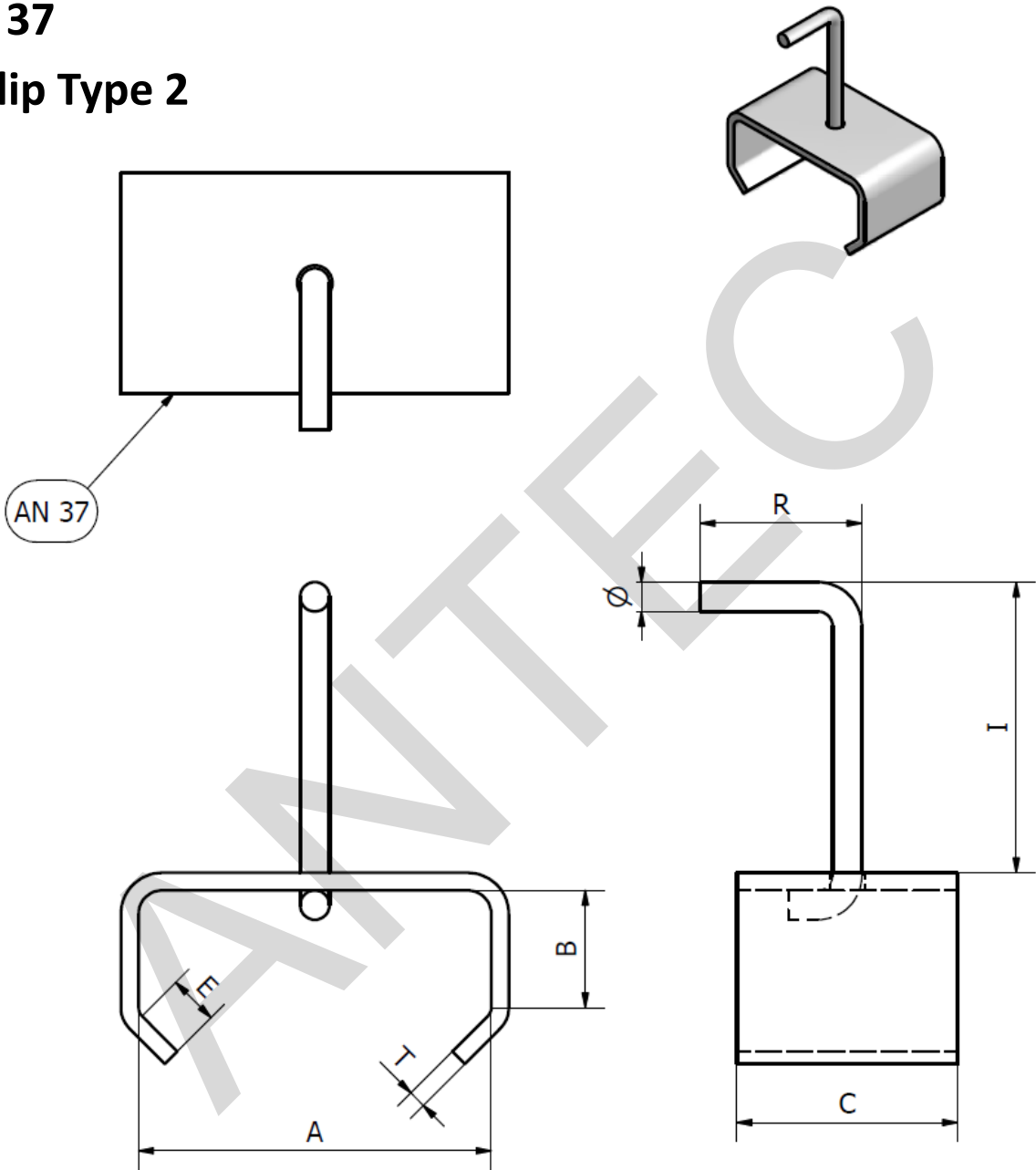

All items can be manufactured in various alloy steels.

Note: Anchor brick type to be specified at time of order.

Tolerances:

+/- 3mm on Dimensional

+/- 3° on Angular Dimensions

Unless otherwise noted.

T = 6mm TYP.

This drawing is the property of Antec Group Pty Ltd and is supplied on the understanding it is not to be used for any purpose, copied or communicated to any other person without written permission of the proprietor. All rights are reserved for product design concept. Antec products are guaranteed to conform within normal commercial tolerance of the applicable description furnished and to be manufactured from material as specified. No other guarantees or warranty, including warranty for fitness of products for in service operating condition shall exist in connection with sale of Antec products. Heat treatment after manufacture is not included unless specified.

Refractory Anchors

AN 38

C Clip Type 3

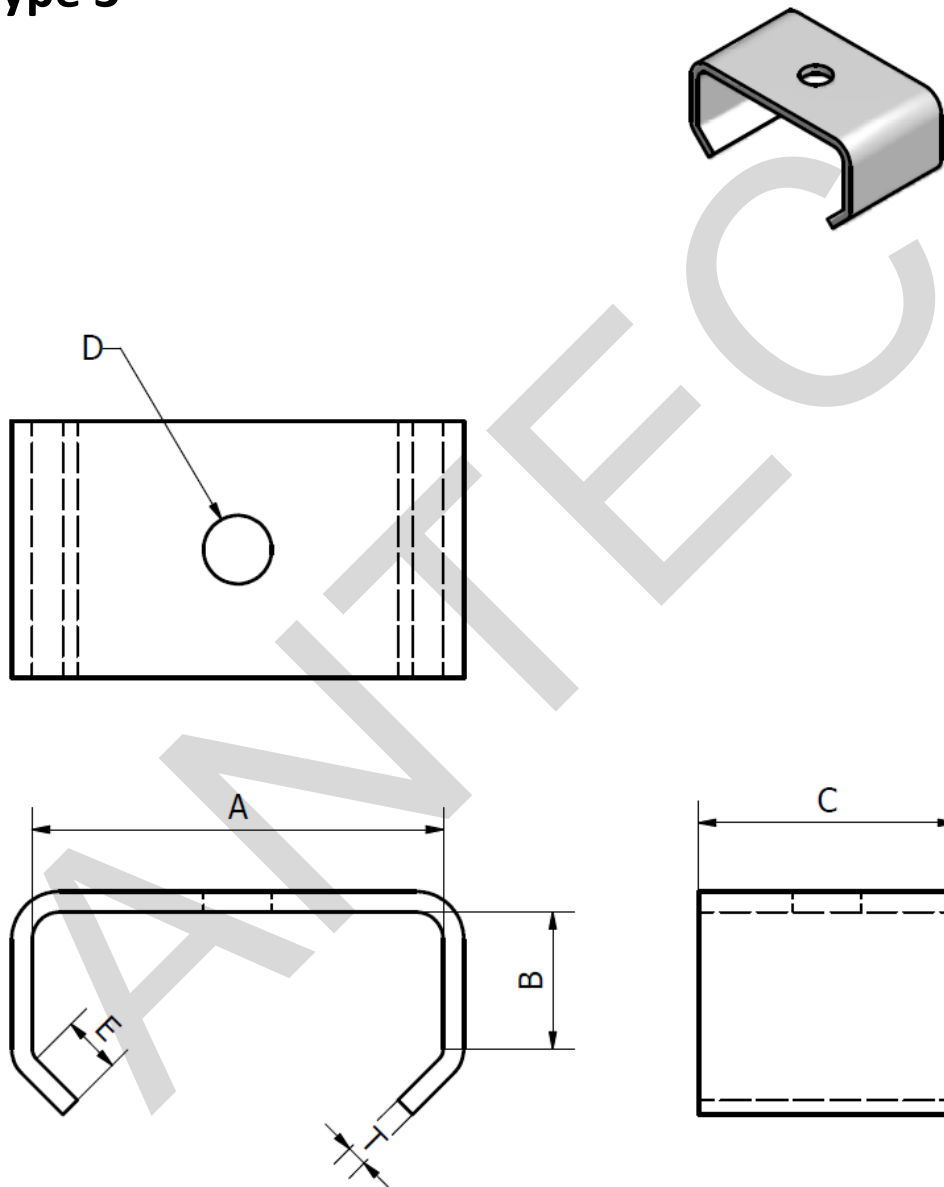

All items can be manufactured in various alloy steels.

Note: Anchor brick type to be specified at time of order.

Tolerances:

+/- 3mm on Dimensional

+/- 3° on Angular Dimensions

Unless otherwise noted.

T = 6mm TYP.

This drawing is the property of Antec Group Pty Ltd and is supplied on the understanding it is not to be used for any purpose, copied or communicated to any other person without written permission of the proprietor. All rights are reserved for product design concept. Antec products are guaranteed to conform within normal commercial tolerance of the applicable description furnished and to be manufactured from material as specified. No other guarantees or warranty, including warranty for fitness of products for in service operating condition shall exist in connection with sale of Antec products. Heat treatment after manufacture is not included unless specified.

Refractory Anchors

AN 39

C Clip Type 4

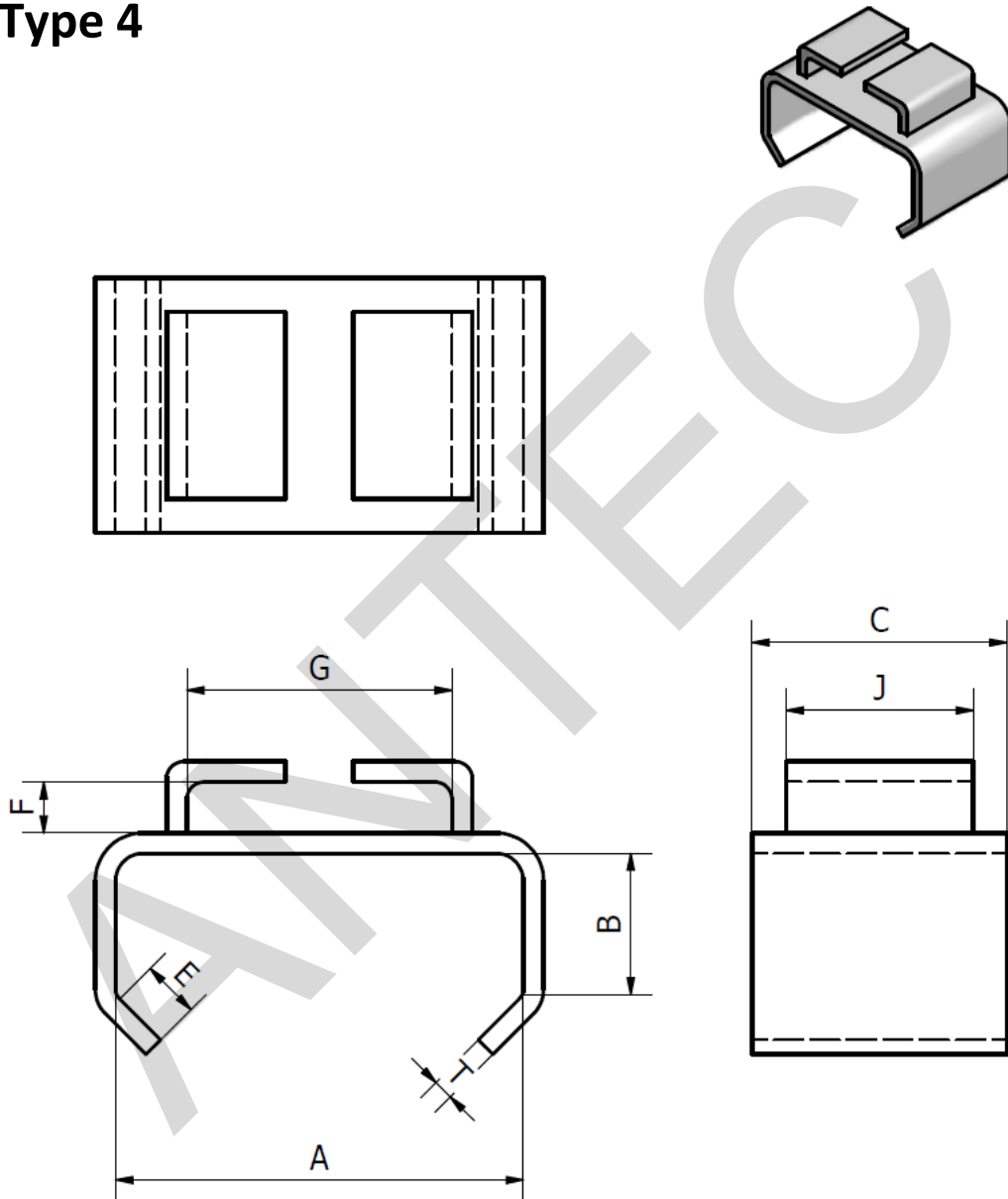

All items can be manufactured in various alloy steels.

Note: Anchor brick type to be specified at time of order.

Tolerances:

+/- 3mm on Dimensional

+/- 3° on Angular Dimensions

Unless otherwise noted.

T = 6mm TYP.

This drawing is the property of Antec Group Pty Ltd and is supplied on the understanding it is not to be used for any purpose, copied or communicated to any other person without written permission of the proprietor. All rights are reserved for product design concept. Antec products are guaranteed to conform within normal commercial tolerance of the applicable description furnished and to be manufactured from material as specified. No other guarantees or warranty, including warranty for fitness of products for in service operating condition shall exist in connection with sale of Antec products. Heat treatment after manufacture is not included unless specified.

Refractory Anchors

AN 40

S Bar Anchor

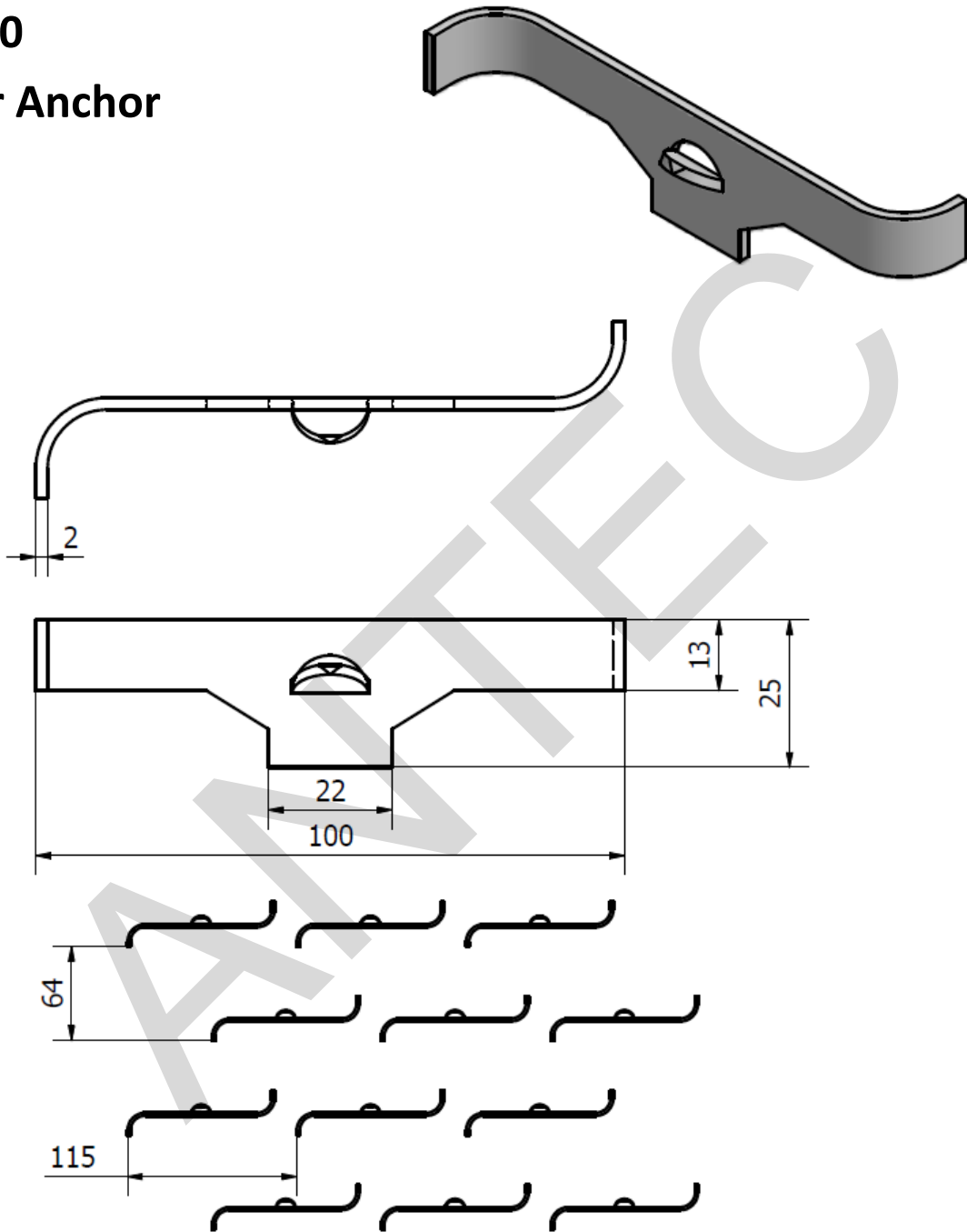

All items can be manufactured in various alloy steels.

Tolerances:

+/- 3mm on Dimensional

+/- 3° on Angular Dimensions

Unless otherwise noted.

Common height dimensions can be 19, 25 or 50 mm but can be altered to suit project requirements.

This drawing is the property of Antec Group Pty Ltd and is supplied on the understanding it is not to be used for any purpose, copied or communicated to any other person without written permission of the proprietor. All rights are reserved for product design concept. Antec products are guaranteed to conform within normal commercial tolerance of the applicable description furnished and to be manufactured from material as specified. No other guarantees or warranty, including warranty for fitness of products for in service operating condition shall exist in connection with sale of Antec products. Heat treatment after manufacture is not included unless specified.

Refractory Anchors

AN 40M

Mini S Bar Anchor

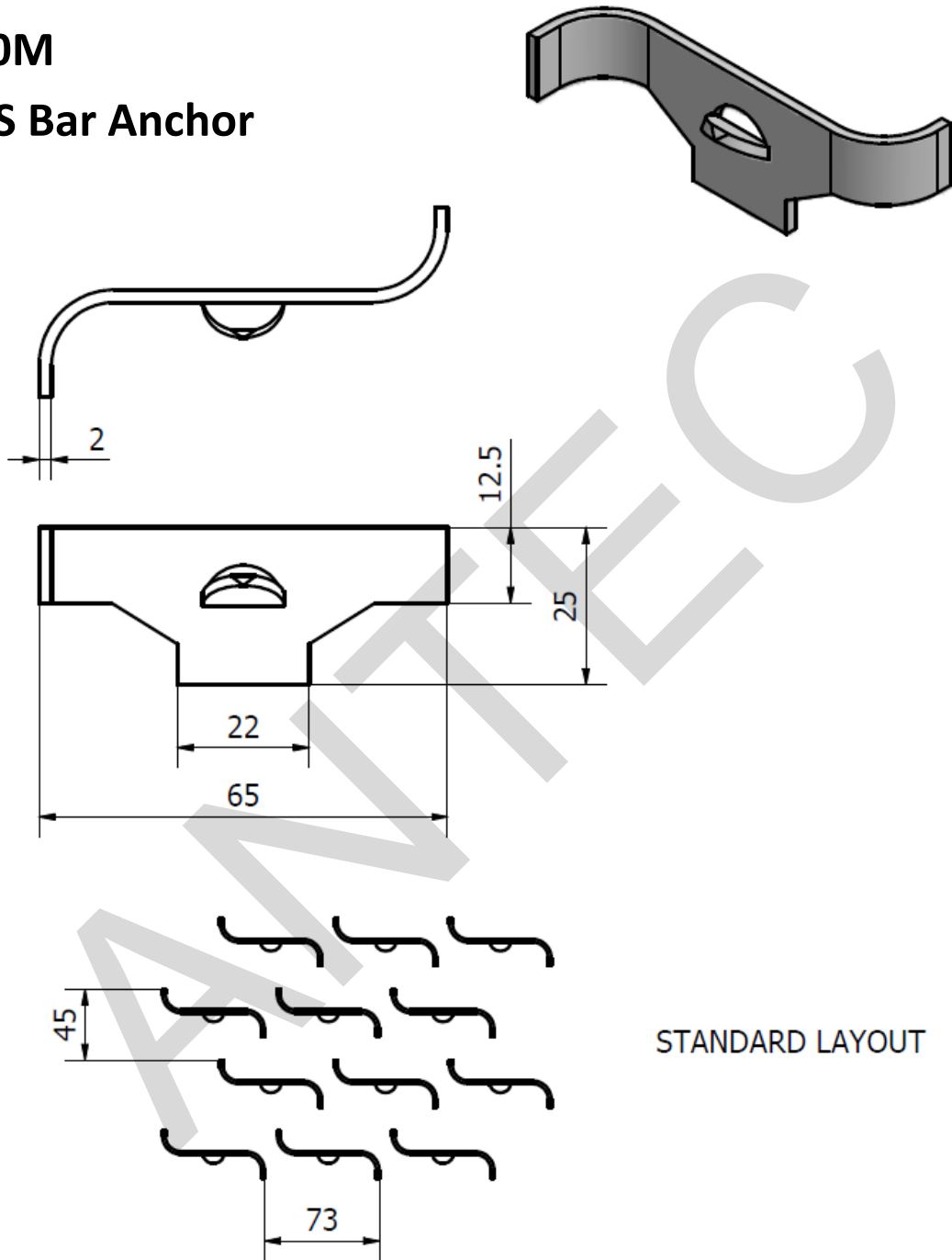

All items can be manufactured in various alloy steels.

Tolerances:

+/- 3mm on Dimensional

+/- 3° on Angular Dimensions

Unless otherwise noted.

Common height dimensions can be 19, 25 or 50 mm but can be altered to suit project requirements.

This drawing is the property of Antec Group Pty Ltd and is supplied on the understanding it is not to be used for any purpose, copied or communicated to any other person without written permission of the proprietor. All rights are reserved for product design concept. Antec products are guaranteed to conform within normal commercial tolerance of the applicable description furnished and to be manufactured from material as specified. No other guarantees or warranty, including warranty for fitness of products for in service operating condition shall exist in connection with sale of Antec products. Heat treatment after manufacture is not included unless specified.

Refractory Anchors

AN 41 – A2

CFF Pin & Washer

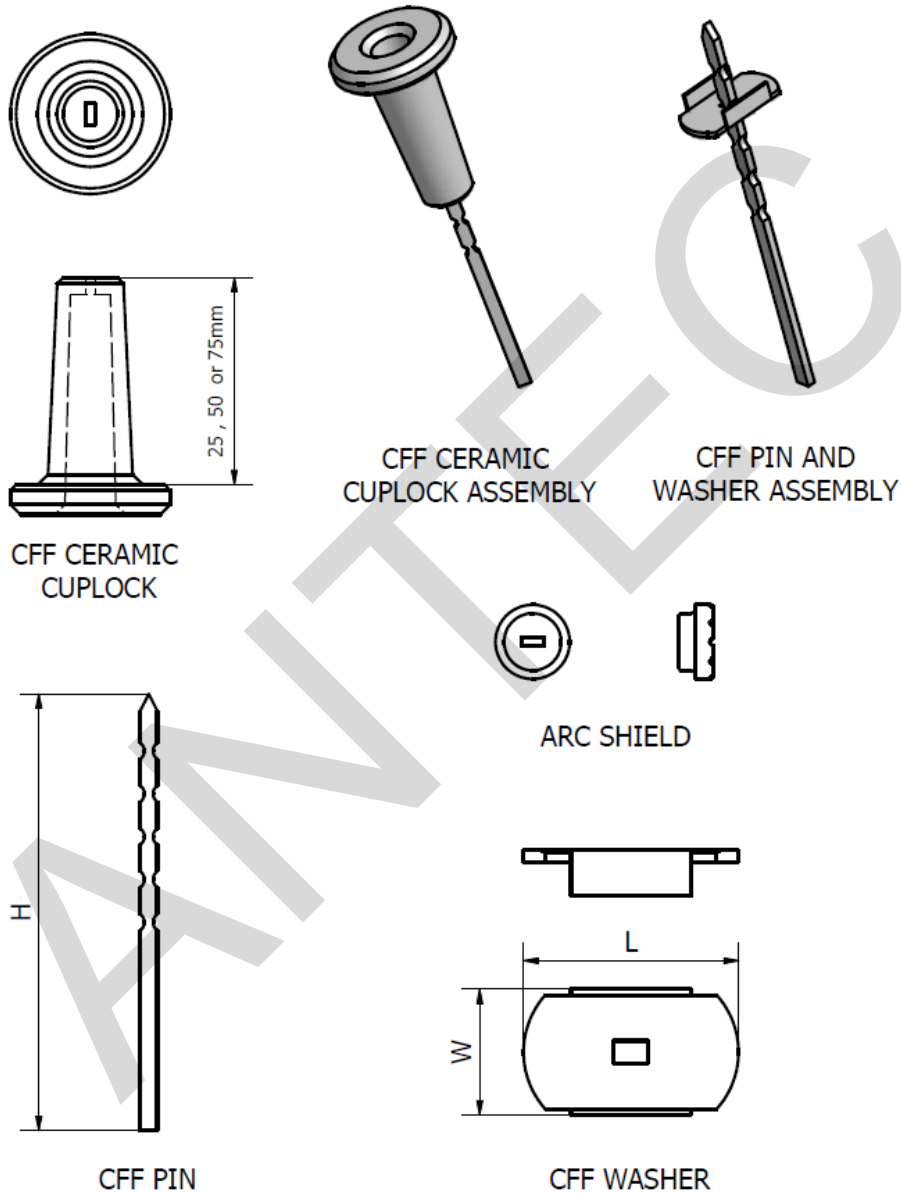

CERAMIC FIBRE ANCHORING SYSTEM

All items can be manufactured in various alloy steels.

Tolerances:

+/- 3mm on Dimensional

+/- 3° on Angular Dimensions

Unless otherwise noted.

This drawing is the property of Antec Group Pty Ltd and is supplied on the understanding it is not to be used for any purpose, copied or communicated to any other person without written permission of the proprietor. All rights are reserved for product design concept. Antec products are guaranteed to conform within normal commercial tolerance of the applicable description furnished and to be manufactured from material as specified. No other guarantees or warranty, including warranty for fitness of products for in service operating condition shall exist in connection with sale of Antec products. Heat treatment after manufacture is not included unless specified.

Refractory Anchors

AN 41C Speedclip

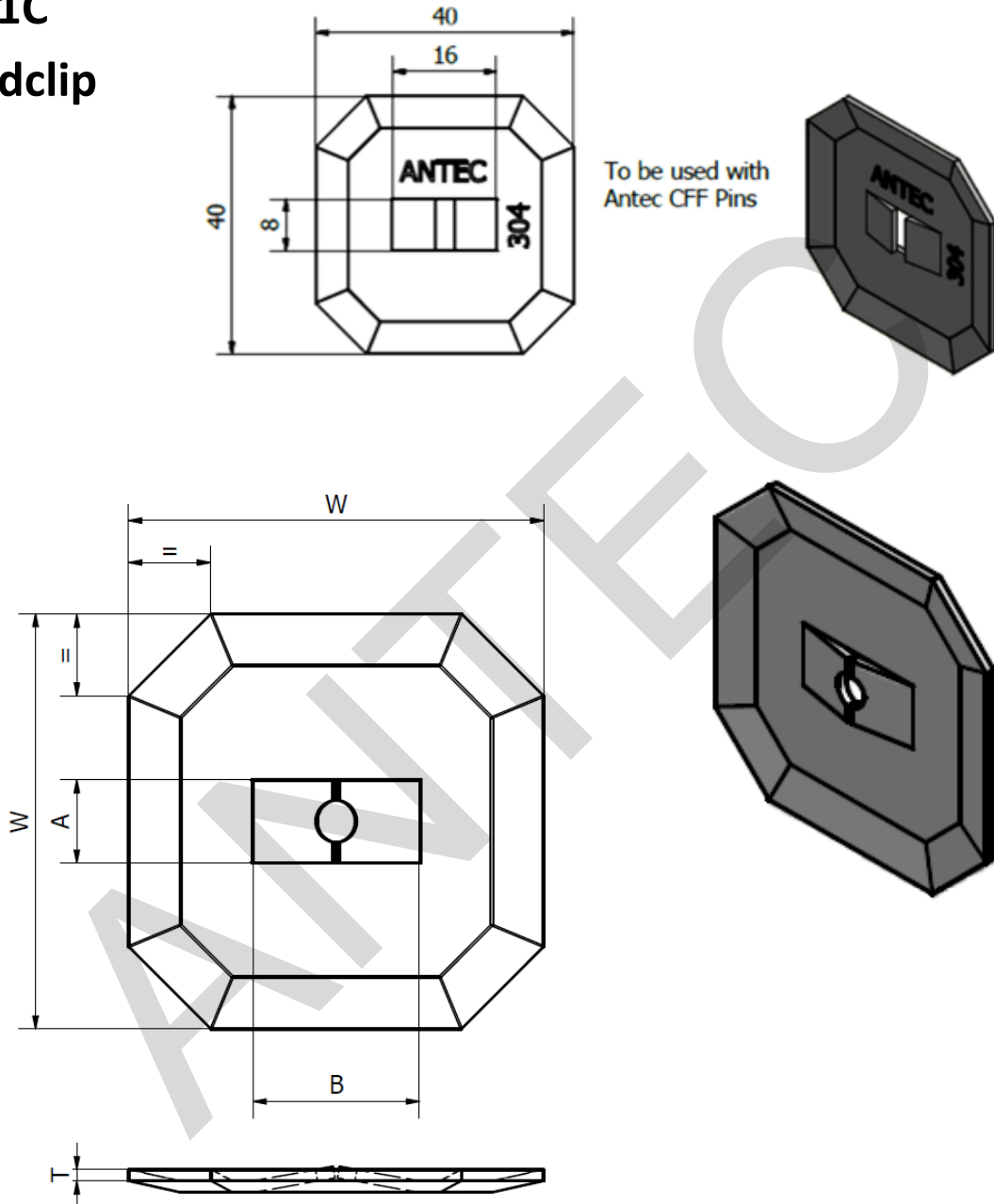

Speedclips are available in carbon steel 304, 310 & other grades upon request. Clips can be made to suit 3, 5, or 6 mm diameter pins and Antec CFF (Flat) Pins.

Tolerances:

+/- 3mm on Dimensional

+/- 3° on Angular Dimensions

Unless otherwise noted.

Typical Thickness T = 0.55 mm.

This drawing is the property of Antec Group Pty Ltd and is supplied on the understanding it is not to be used for any purpose, copied or communicated to any other person without written permission of the proprietor. All rights are reserved for product design concept. Antec products are guaranteed to conform within normal commercial tolerance of the applicable description furnished and to be manufactured from material as specified. No other guarantees or warranty, including warranty for fitness of products for in service operating condition shall exist in connection with sale of Antec products. Heat treatment after manufacture is not included unless specified.

Refractory Anchors

AN 42A

Wireform Spearlock

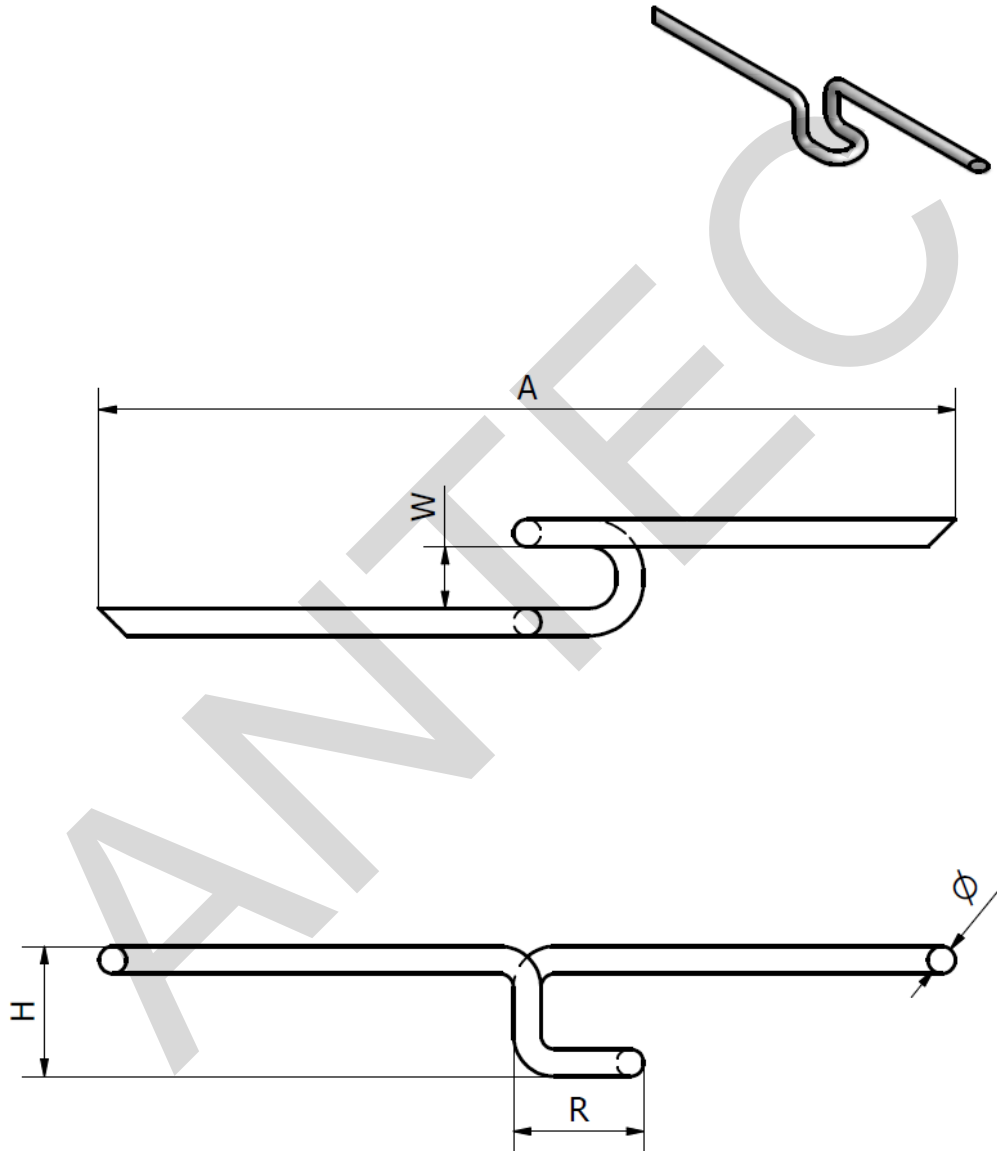

All items can be manufactured in various alloy steels.

Tolerances:

+/- 3mm on Dimensional

+/- 3° on Angular Dimensions

Unless otherwise noted.

This drawing is the property of Antec Group Pty Ltd and is supplied on the understanding it is not to be used for any purpose, copied or communicated to any other person without written permission of the proprietor. All rights are reserved for product design concept. Antec products are guaranteed to conform within normal commercial tolerance of the applicable description furnished and to be manufactured from material as specified. No other guarantees or warranty, including warranty for fitness of products for in service operating condition shall exist in connection with sale of Antec products. Heat treatment after manufacture is not included unless specified.

Refractory Anchors

AN 43

Threaded Snap Tie

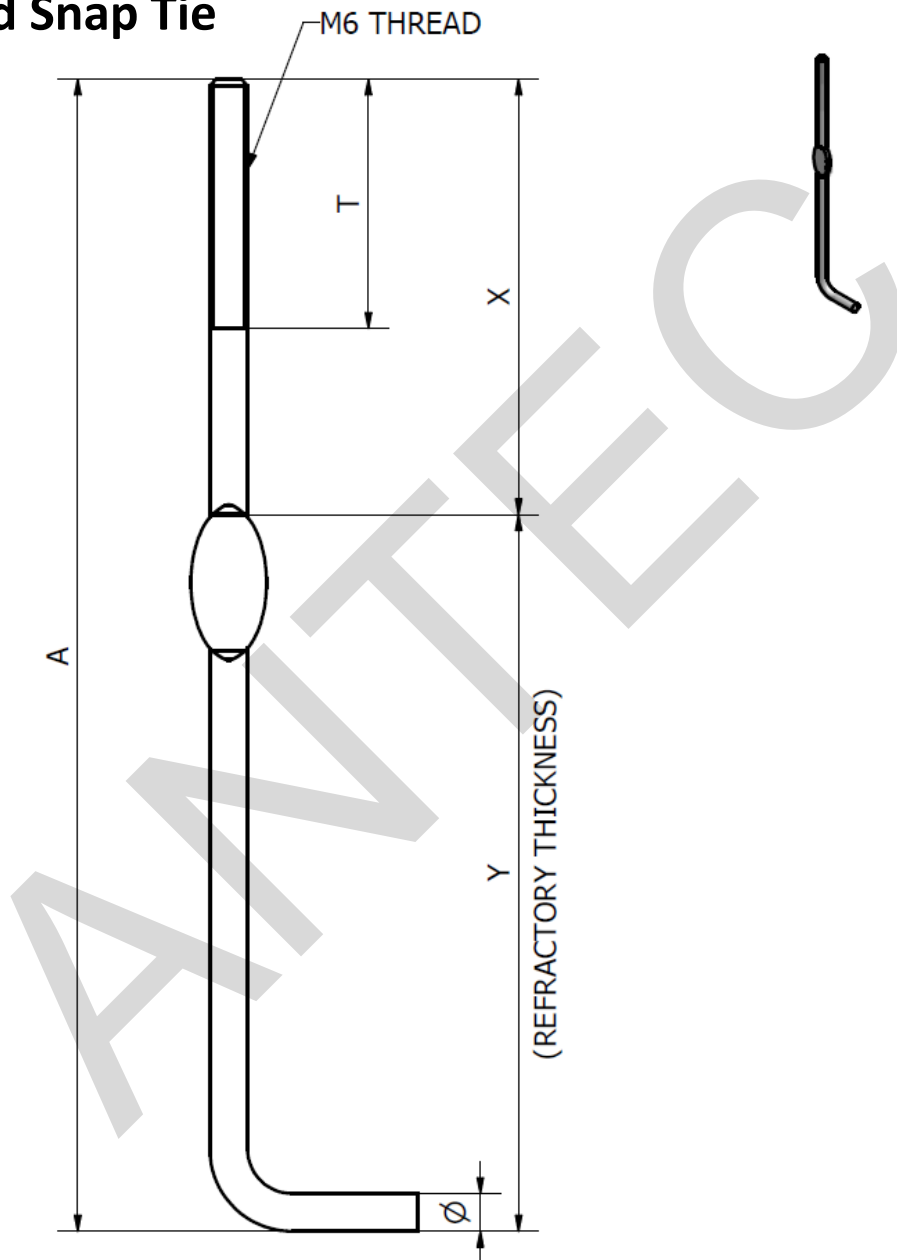

All items can be manufactured in various alloy steels.

Note: Maximum thread length 40mm M6.

Tolerances:

+/- 3mm on Dimensional

+/- 3° on Angular Dimensions

Unless otherwise noted.

This drawing is the property of Antec Group Pty Ltd and is supplied on the understanding it is not to be used for any purpose, copied or communicated to any other person without written permission of the proprietor. All rights are reserved for product design concept. Antec products are guaranteed to conform within normal commercial tolerance of the applicable description furnished and to be manufactured from material as specified. No other guarantees or warranty, including warranty for fitness of products for in service operating condition shall exist in connection with sale of Antec products. Heat treatment after manufacture is not included unless specified.

Refractory Anchors

AN 43A

Snap Tie (Capped)

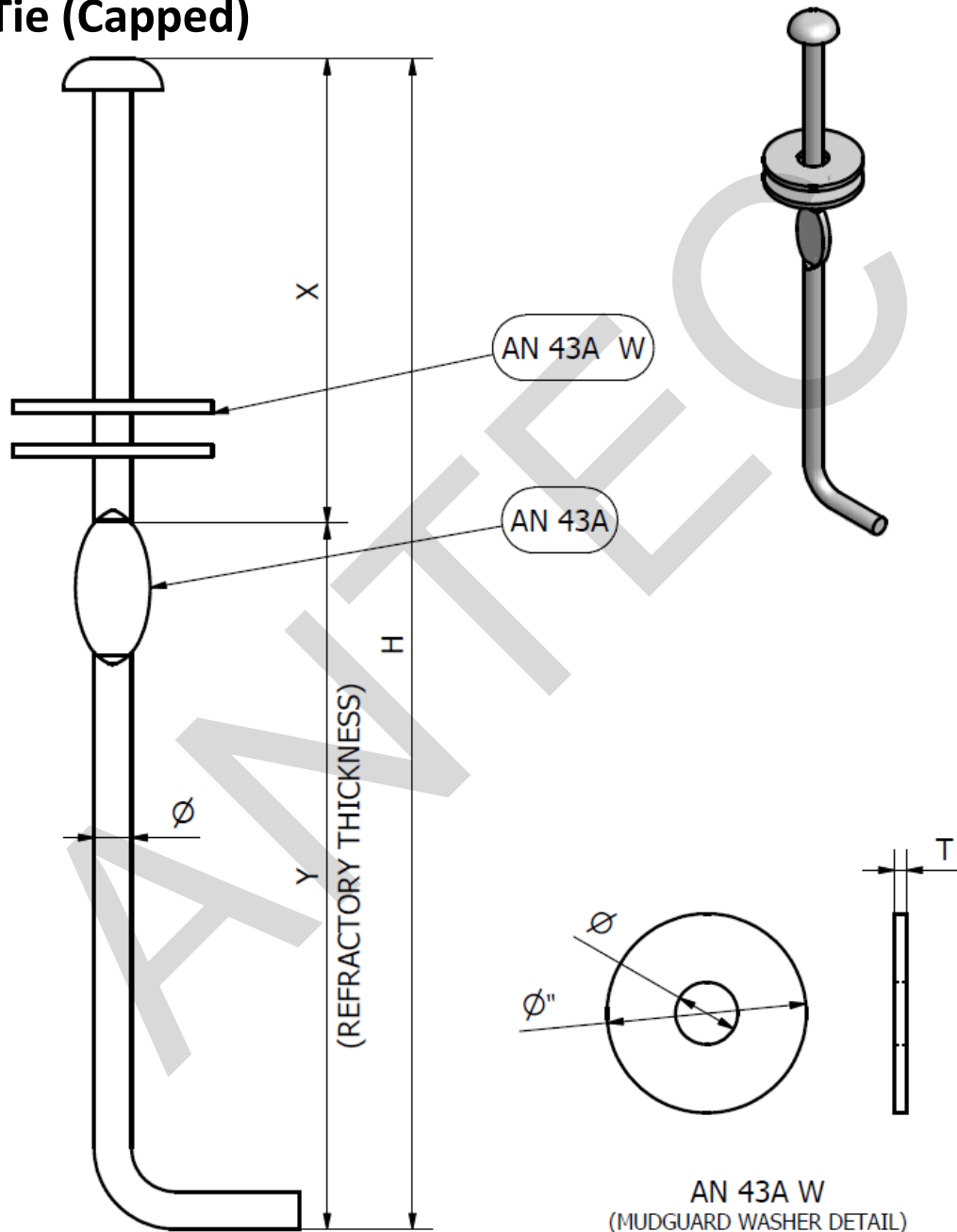

All items can be manufactured in various alloy steels.

Tolerances:

+/- 3mm on Dimensional

+/- 3° on Angular Dimensions

Unless otherwise noted.

This drawing is the property of Antec Group Pty Ltd and is supplied on the understanding it is not to be used for any purpose, copied or communicated to any other person without written permission of the proprietor. All rights are reserved for product design concept. Antec products are guaranteed to conform within normal commercial tolerance of the applicable description furnished and to be manufactured from material as specified. No other guarantees or warranty, including warranty for fitness of products for in service operating condition shall exist in connection with sale of Antec products. Heat treatment after manufacture is not included unless specified.

Refractory Anchors

AN 44

BT Anchor

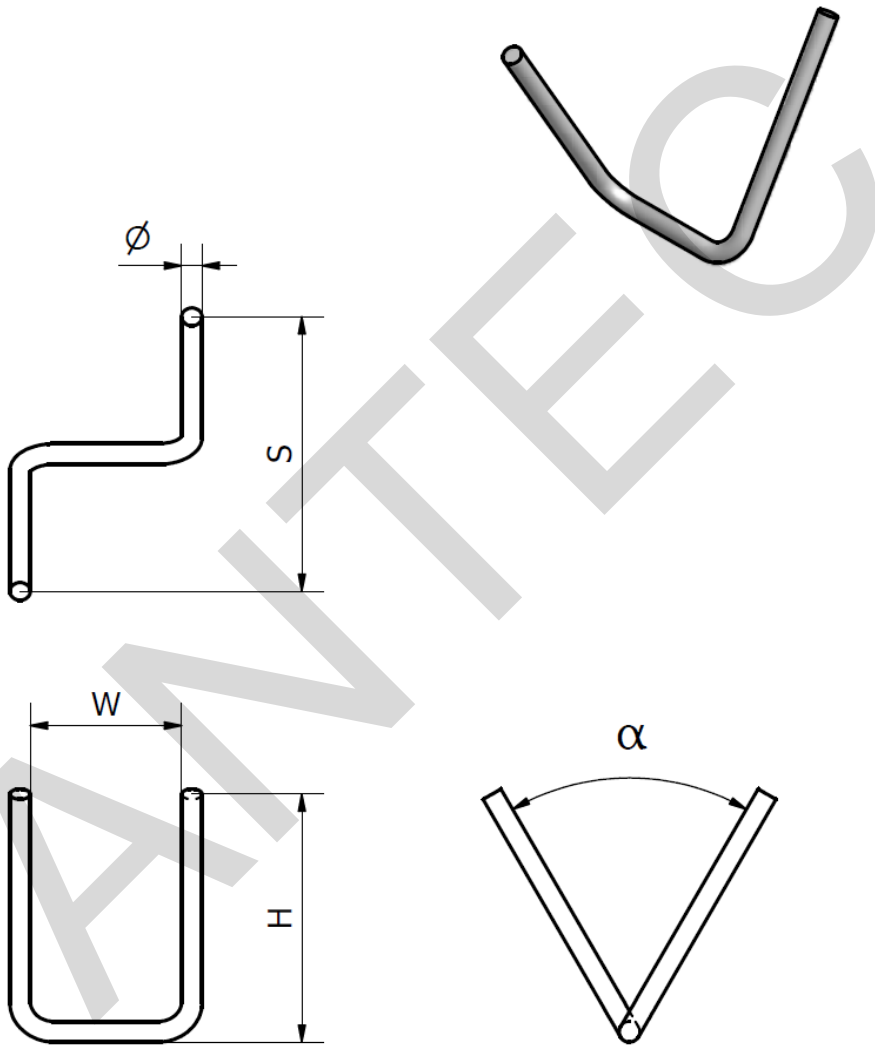

All items can be manufactured in various alloy steels.

Tolerances:

+/- 3mm on Dimensional

+/- 3° on Angular Dimensions

Unless otherwise noted.

This drawing is the property of Antec Group Pty Ltd and is supplied on the understanding it is not to be used for any purpose, copied or communicated to any other person without written permission of the proprietor. All rights are reserved for product design concept. Antec products are guaranteed to conform within normal commercial tolerance of the applicable description furnished and to be manufactured from material as specified. No other guarantees or warranty, including warranty for fitness of products for in service operating condition shall exist in connection with sale of Antec products. Heat treatment after manufacture is not included unless specified.

Refractory Anchors

AN 56

Straplock System

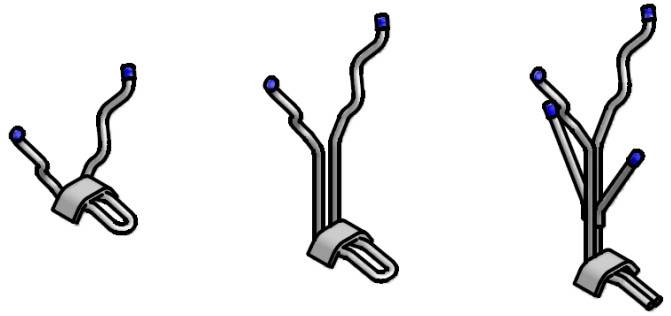

Advantages of the Antec Straplock system:

1. The V anchor is held securely by the Strap or Cleat but also has the ability to move with the lining, reducing stresses in the castable (for reduced crack potential) and stresses on the anchor (for reduced breakage potential).
2. While the V anchor has the ability to move with the lining at the same time it is held securely by the Strap so there is no chance of it collapsing when installing refractory.
3. The Cleat or Strap is welded to the furnace shell before the V anchor is inserted; therefore the V anchor is not subject to damage from foot or equipment traffic in kiln. This overcomes a common issue of re-bending welded V anchors that were bent prior to installation of refractory. Re-bending of welded anchors can also reduce service performance.
4. The Cleat or Strap can be manufactured from a lower grade alloy or carbon steel as it is at the back of the lining. This can result in lower raw material costs and lower welding costs as less expensive, commonly available electrodes can be used.
5. Improves safety for traffic in kiln as the V anchors are only installed just prior to the installation of the lining, thereby avoiding the "forest of anchors". The Antec Straplock also simplifies the handling of prefabricated components.
6. The Antec Straplock has the potential to reuse the bases when repairing or relining, saving on downtime, welded anchor removal, welding time and cost for replacements.
7. The V anchors can be installed into the straps in a directional radial pattern along the kiln. This can facilitate fast demolition as jack hammering can be done along the kiln in the opposite direction so that the anchor easily comes out of the strap and no angle grinding is required.

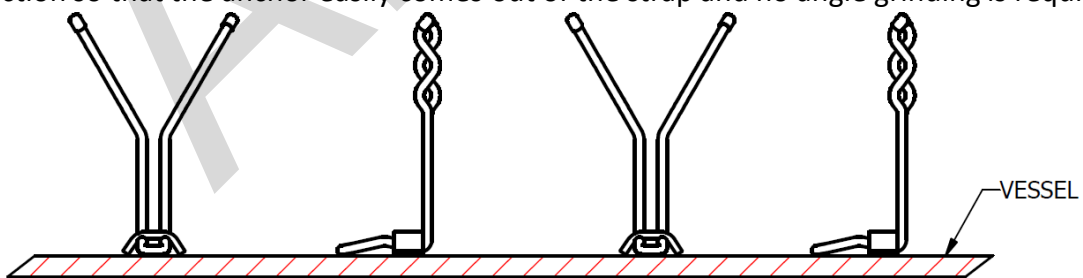

8. The straps can be reused after demolition. This anchor design utilises a resistance grip, not an interference grip, to hold the V anchor in place allowing anchors to be replaced without the need to replace the strap.
9. Utilising a YDX anchor increases cross sectional area to resist stresses and horizontal forces. For thicker linings it also enables extra prongs to be welded to the closed legs for increased anchorage.

Refractory Anchors

AN 56A

YD2X with Cleat or Strap

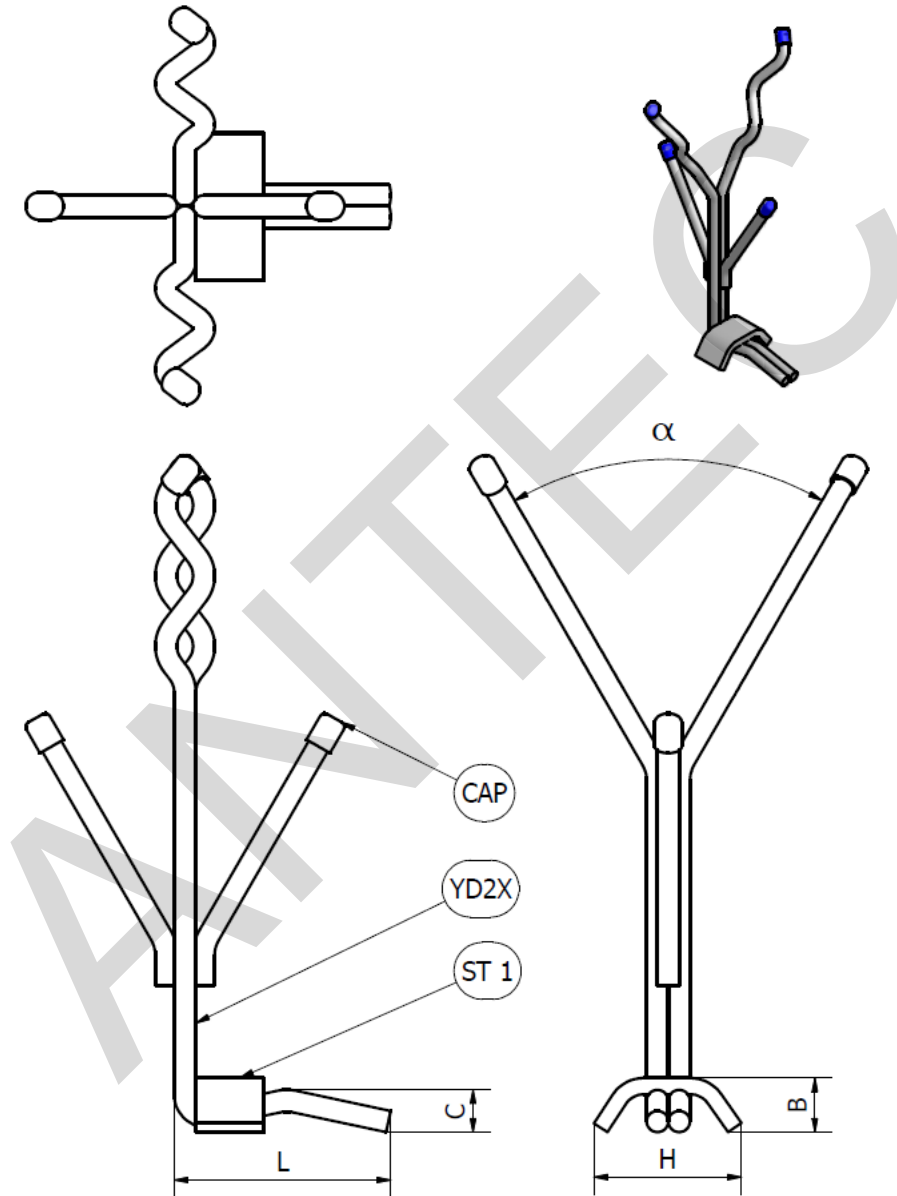

All items can be manufactured in various alloy steels.

Tolerances:

+/- 3mm on Dimensional

+/- 3° on Angular Dimensions

Unless otherwise noted.

Caps can be supplied if requested.

This drawing is the property of Antec Group Pty Ltd and is supplied on the understanding it is not to be used for any purpose, copied or communicated to any other person without written permission of the proprietor. All rights are reserved for product design concept. Antec products are guaranteed to conform within normal commercial tolerance of the applicable description furnished and to be manufactured from material as specified. No other guarantees or warranty, including warranty for fitness of products for in service operating condition shall exist in connection with sale of Antec products. Heat treatment after manufacture is not included unless specified.

Refractory Anchors

AN 56B

YCL with Cleat or Strap

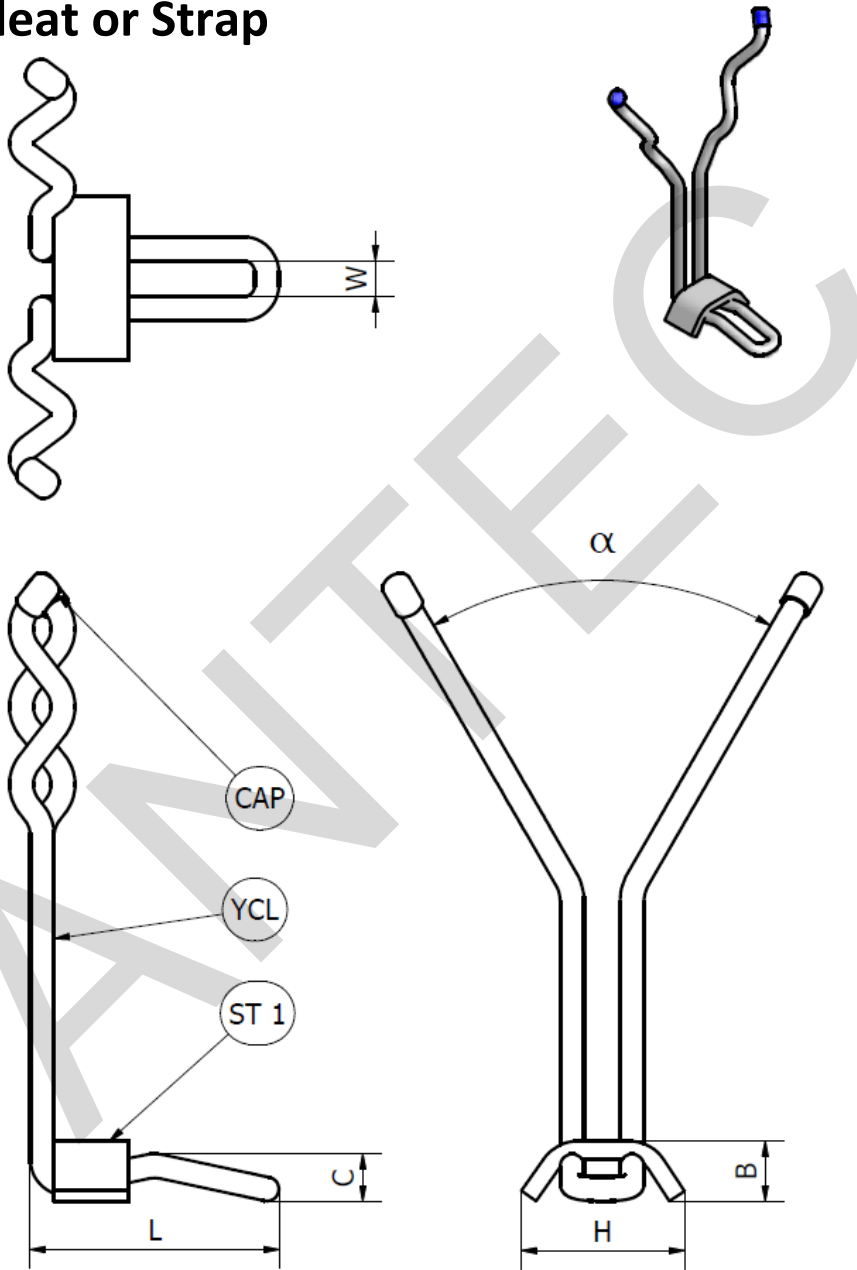

All items can be manufactured in various alloy steels.

Tolerances:

+/- 3mm on Dimensional

+/- 3° on Angular Dimensions

Unless otherwise noted.

Caps can be supplied if requested.

This drawing is the property of Antec Group Pty Ltd and is supplied on the understanding it is not to be used for any purpose, copied or communicated to any other person without written permission of the proprietor. All rights are reserved for product design concept. Antec products are guaranteed to conform within normal commercial tolerance of the applicable description furnished and to be manufactured from material as specified. No other guarantees or warranty, including warranty for fitness of products for in service operating condition shall exist in connection with sale of Antec products. Heat treatment after manufacture is not included unless specified.

Refractory Anchors

AN 56C

VCL with Cleat or Strap

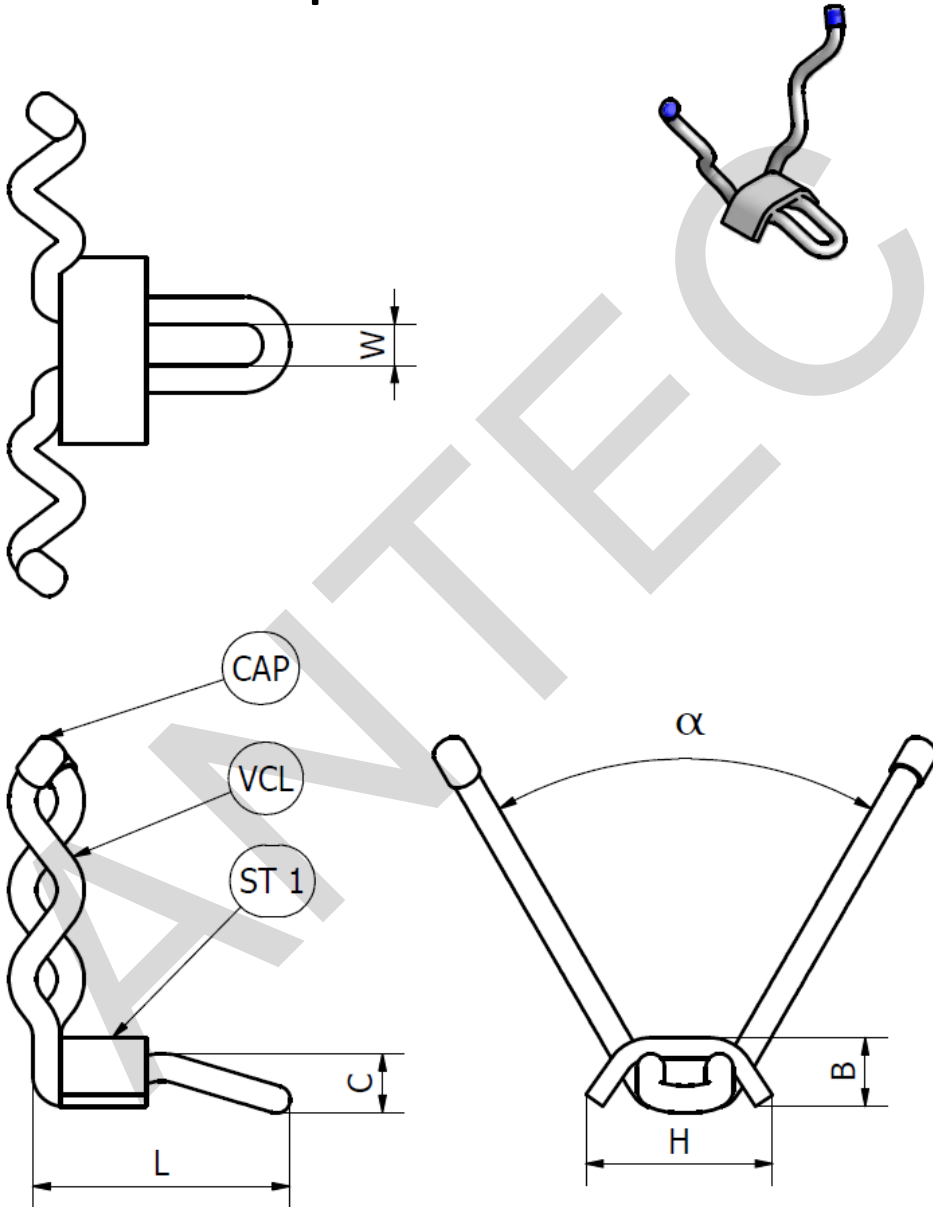

All items can be manufactured in various alloy steels.

Tolerances:

+/- 3mm on Dimensional

+/- 3° on Angular Dimensions

Unless otherwise noted.

Caps can be supplied if requested.

This drawing is the property of Antec Group Pty Ltd and is supplied on the understanding it is not to be used for any purpose, copied or communicated to any other person without written permission of the proprietor. All rights are reserved for product design concept. Antec products are guaranteed to conform within normal commercial tolerance of the applicable description furnished and to be manufactured from material as specified. No other guarantees or warranty, including warranty for fitness of products for in service operating condition shall exist in connection with sale of Antec products. Heat treatment after manufacture is not included unless specified.

Refractory Anchors

AN 56D

Strap

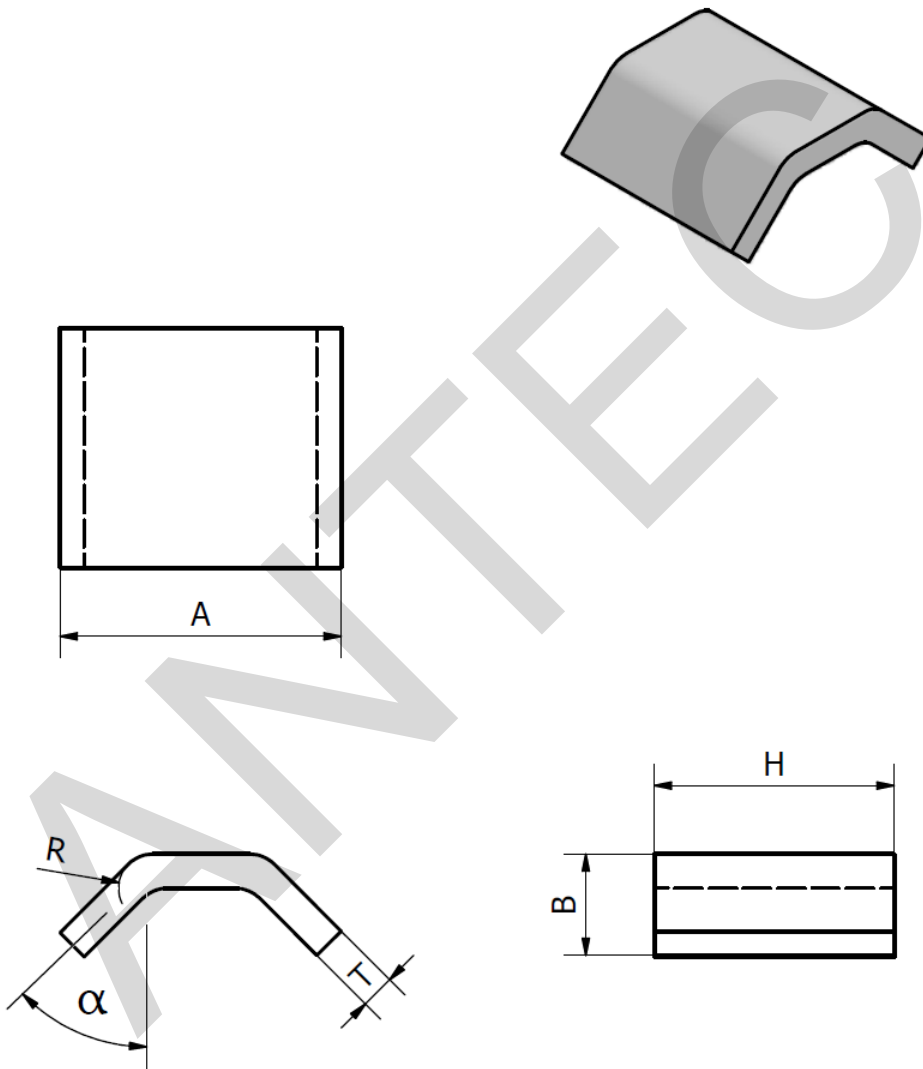

All items can be manufactured in various alloy steels.

Tolerances:

+/- 3mm on Dimensional

+/- 3° on Angular Dimensions

Unless otherwise noted.

This drawing is the property of Antec Group Pty Ltd and is supplied on the understanding it is not to be used for any purpose, copied or communicated to any other person without written permission of the proprietor. All rights are reserved for product design concept. Antec products are guaranteed to conform within normal commercial tolerance of the applicable description furnished and to be manufactured from material as specified. No other guarantees or warranty, including warranty for fitness of products for in service operating condition shall exist in connection with sale of Antec products. Heat treatment after manufacture is not included unless specified.

Refractory Anchors

AN 68

Plate Hook

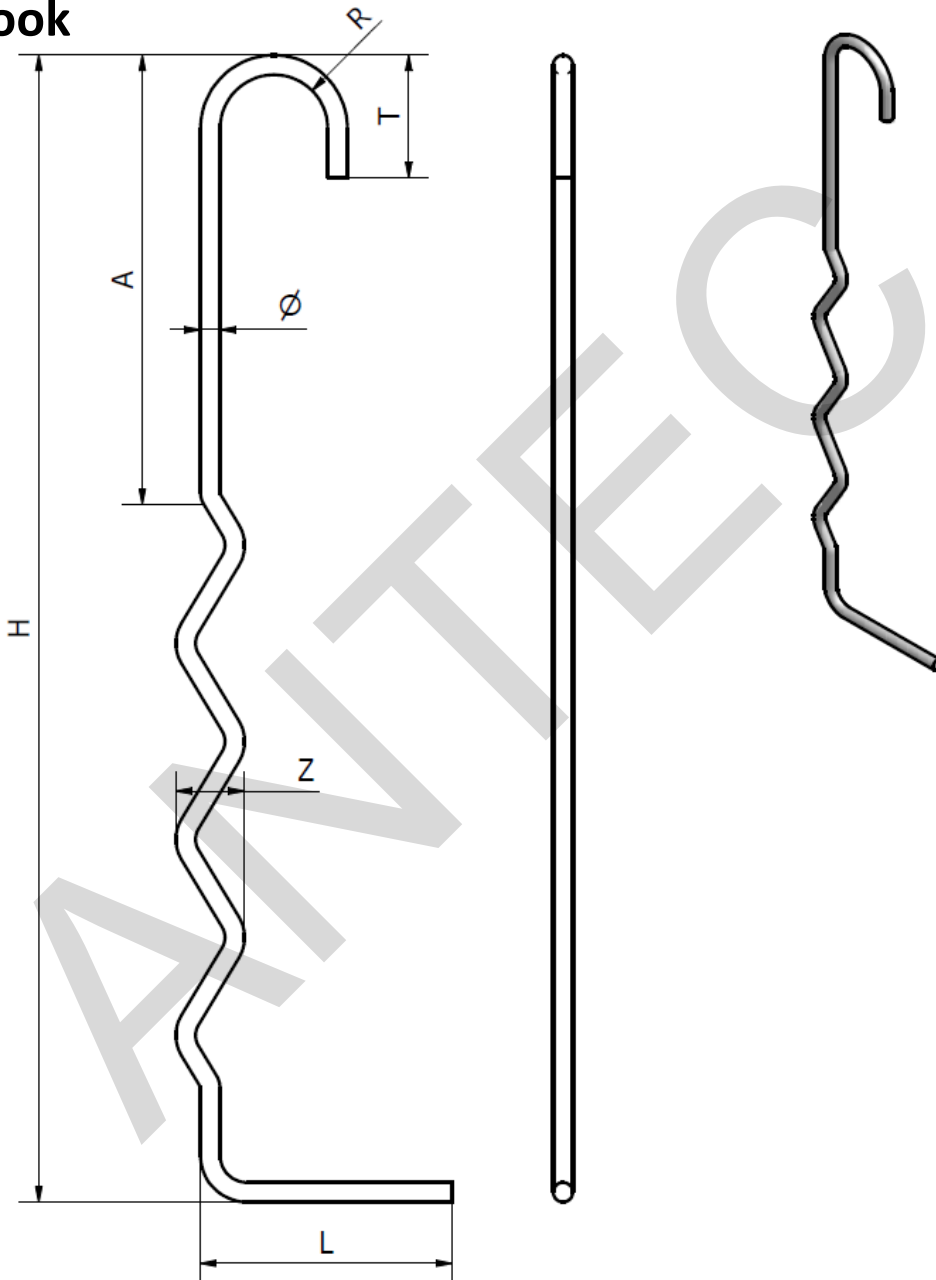

All items can be manufactured in various alloy steels.

Tolerances:

+/- 3mm on Dimensional

+/- 3° on Angular Dimensions

Unless otherwise noted

Corrugation as drawn is diagrammatic only.

This drawing is the property of Antec Group Pty Ltd and is supplied on the understanding it is not to be used for any purpose, copied or communicated to any other person without written permission of the proprietor. All rights are reserved for product design concept. Antec products are guaranteed to conform within normal commercial tolerance of the applicable description furnished and to be manufactured from material as specified. No other guarantees or warranty, including warranty for fitness of products for in service operating condition shall exist in connection with sale of Antec products. Heat treatment after manufacture is not included unless specified.

Refractory Anchors

AN 74

Looped Base Hair Pin

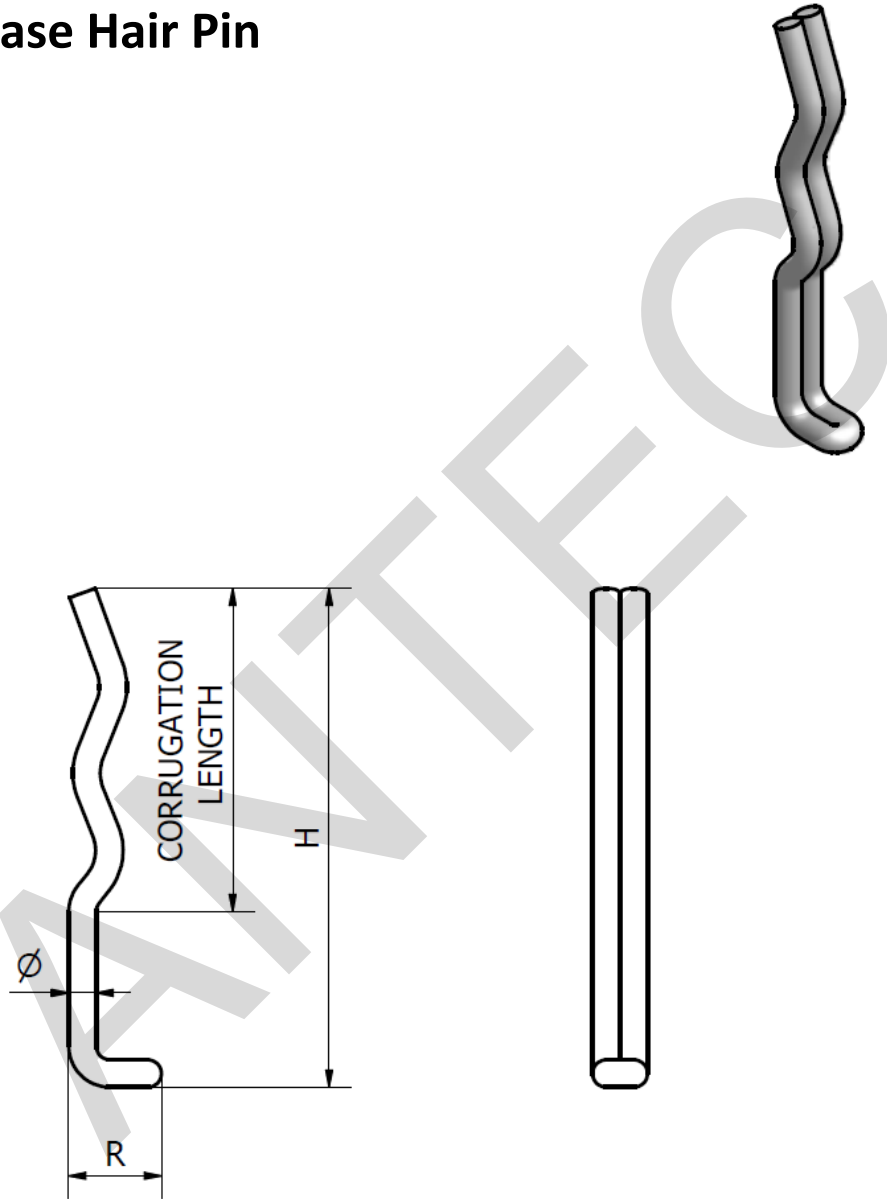

All items can be manufactured in various alloy steels.
All dimensions are to be specified by the customer at time.

Tolerances:

- +/- 3mm on Dimensional
- +/- 3° on Angular Dimensions
- Unless otherwise noted

Corrugation as drawn is diagrammatic only.
Typical wire diameters are 6 and 8 mm.

This drawing is the property of Antec Group Pty Ltd and is supplied on the understanding it is not to be used for any purpose, copied or communicated to any other person without written permission of the proprietor. All rights are reserved for product design concept. Antec products are guaranteed to conform within normal commercial tolerance of the applicable description furnished and to be manufactured from material as specified. No other guarantees or warranty, including warranty for fitness of products for in service operating condition shall exist in connection with sale of Antec products. Heat treatment after manufacture is not included unless specified.

Refractory Anchors

AN 75

Hook (Threaded)

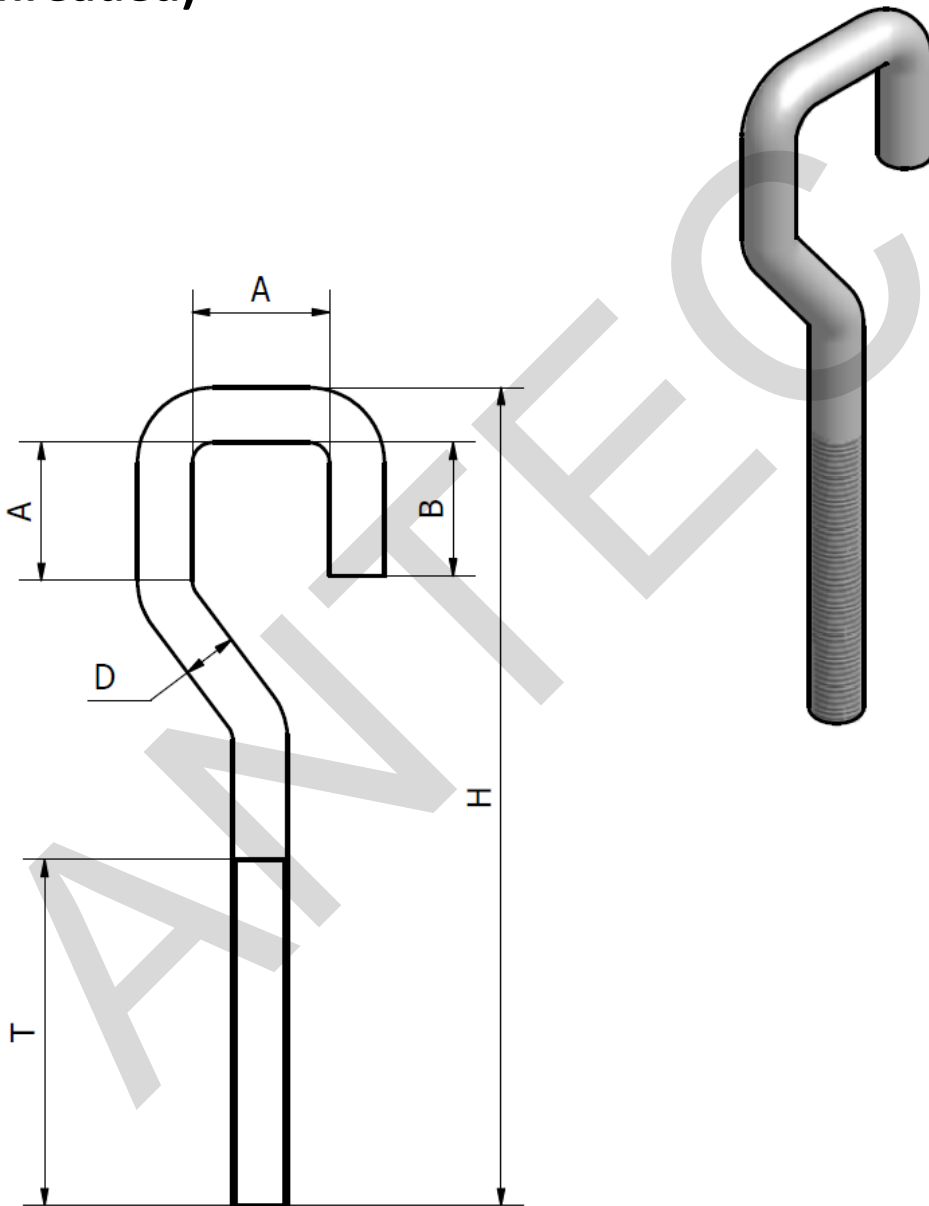

All items can be manufactured in various alloy steels.

Tolerances:

+/- 3mm on Dimensional

+/- 3° on Angular Dimensions

Unless otherwise noted.

This drawing is the property of Antec Group Pty Ltd and is supplied on the understanding it is not to be used for any purpose, copied or communicated to any other person without written permission of the proprietor. All rights are reserved for product design concept. Antec products are guaranteed to conform within normal commercial tolerance of the applicable description furnished and to be manufactured from material as specified. No other guarantees or warranty, including warranty for fitness of products for in service operating condition shall exist in connection with sale of Antec products. Heat treatment after manufacture is not included unless specified.

Refractory Anchors

DAS 1

Das Strips

Patent Design

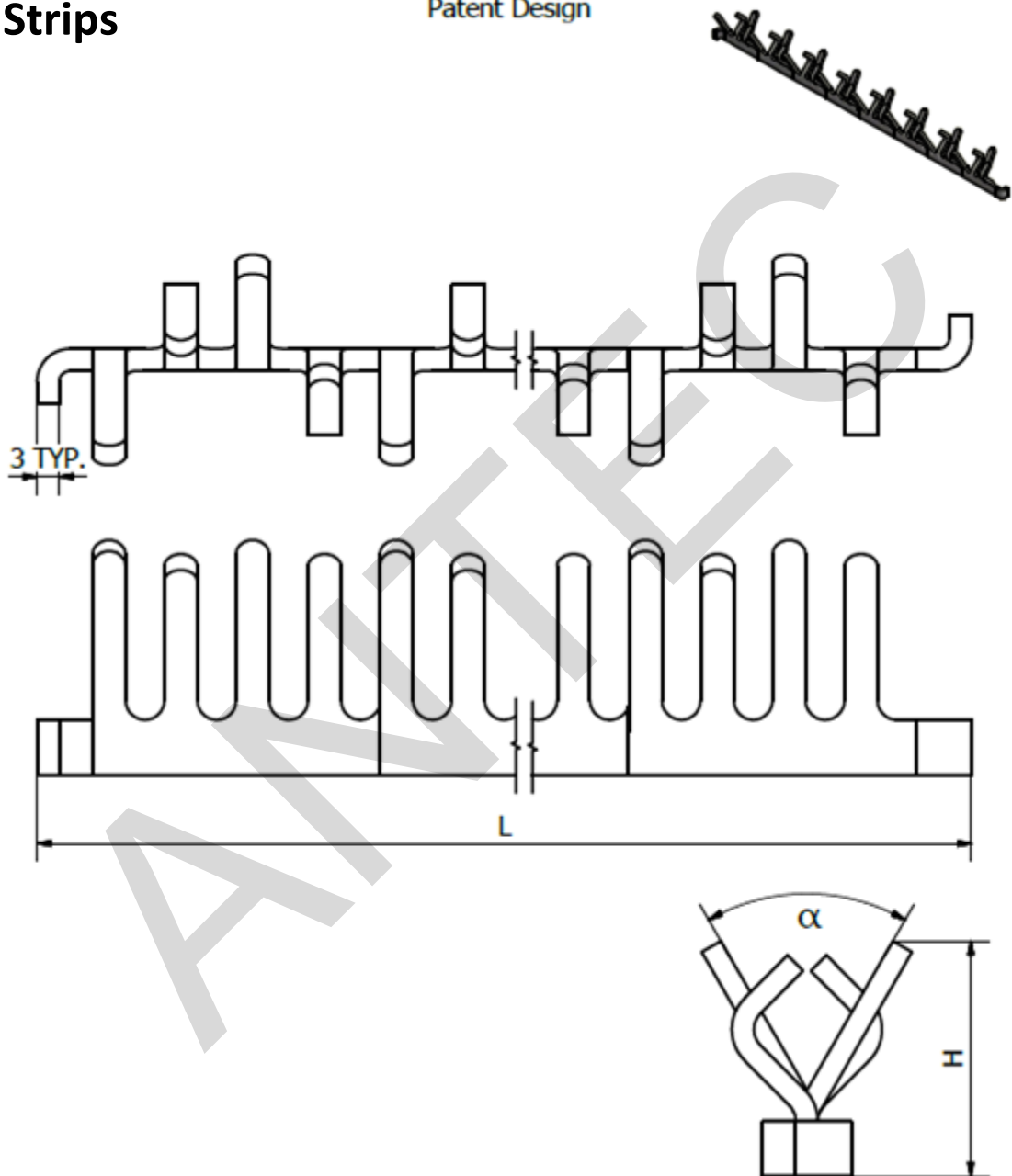

All items can be manufactured in various alloy steels.

Tolerances:

+/- 3mm on Dimensional

+/- 3° on Angular Dimensions

Unless otherwise noted.

This drawing is the property of Antec Group Pty Ltd and is supplied on the understanding it is not to be used for any purpose, copied or communicated to any other person without written permission of the proprietor. All rights are reserved for product design concept. Antec products are guaranteed to conform within normal commercial tolerance of the applicable description furnished and to be manufactured from material as specified. No other guarantees or warranty, including warranty for fitness of products for in service operating condition shall exist in connection with sale of Antec products. Heat treatment after manufacture is not included unless specified.

Refractory Anchors

DAS 2

Circular Das

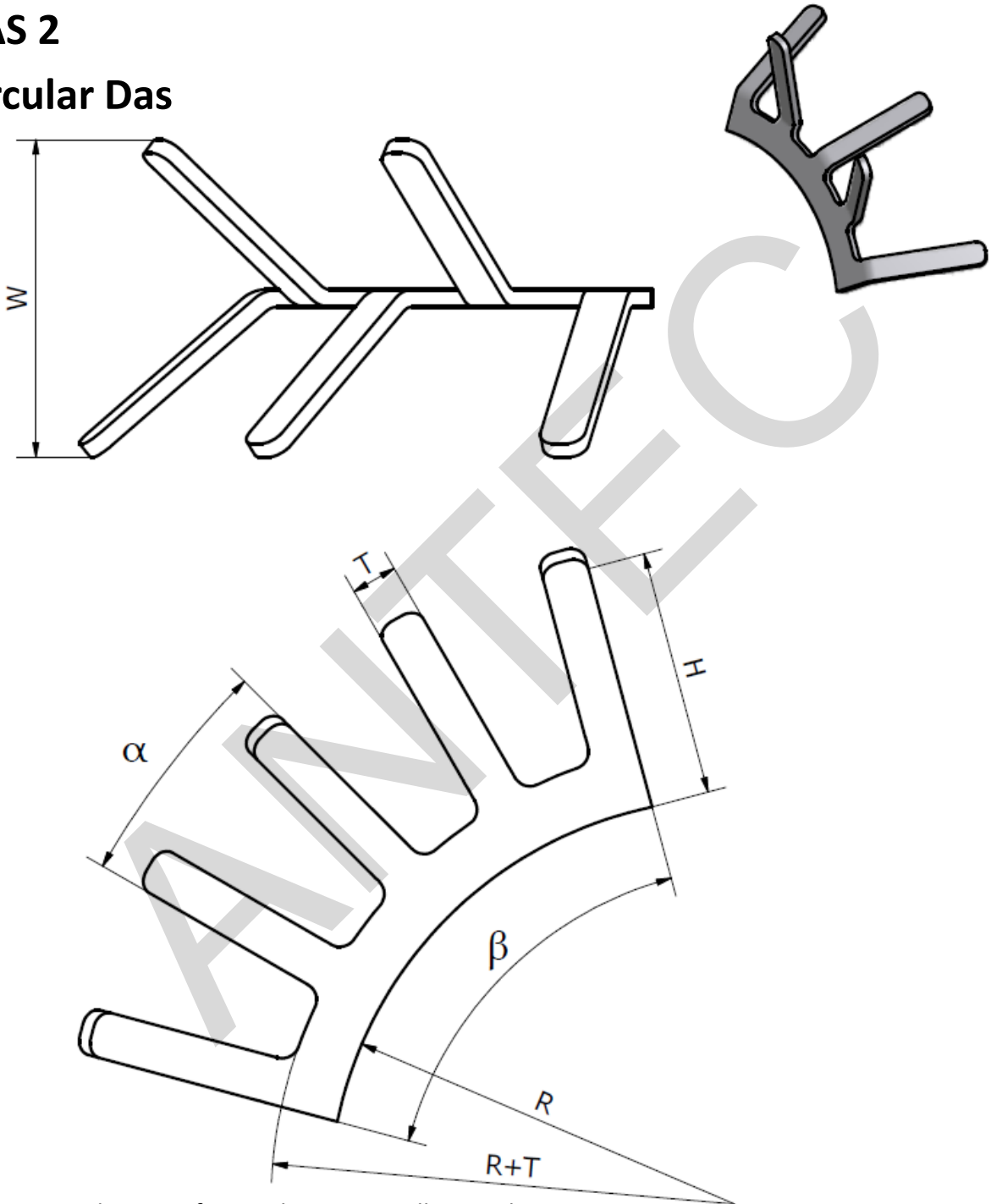

All items can be manufactured in various alloy steels.

Tolerances:

+/- 3mm on Dimensional

+/- 3° on Angular Dimensions

Unless otherwise noted.

This drawing is the property of Antec Group Pty Ltd and is supplied on the understanding it is not to be used for any purpose, copied or communicated to any other person without written permission of the proprietor. All rights are reserved for product design concept. Antec products are guaranteed to conform within normal commercial tolerance of the applicable description furnished and to be manufactured from material as specified. No other guarantees or warranty, including warranty for fitness of products for in service operating condition shall exist in connection with sale of Antec products. Heat treatment after manufacture is not included unless specified.

Refractory Anchors

SB 1

Shelf Bracket (Long)

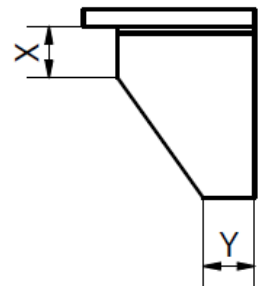
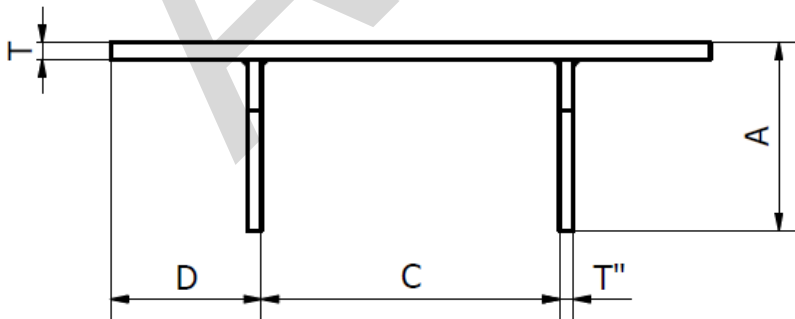
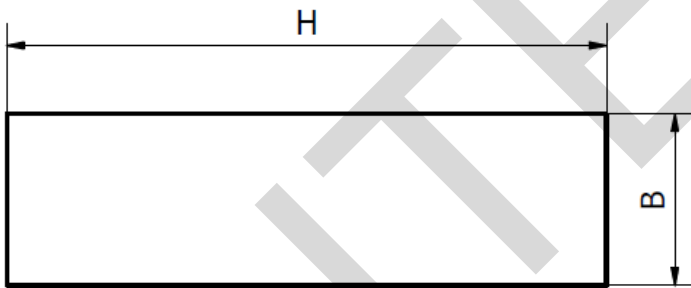
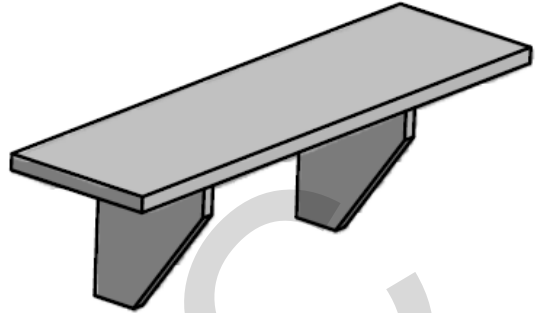

All items can be manufactured in various alloy steels.

Tolerances:

+/- 3mm on Dimensional

+/- 3° on Angular Dimensions

Unless otherwise noted.

This drawing is the property of Antec Group Pty Ltd and is supplied on the understanding it is not to be used for any purpose, copied or communicated to any other person without written permission of the proprietor. All rights are reserved for product design concept. Antec products are guaranteed to conform within normal commercial tolerance of the applicable description furnished and to be manufactured from material as specified. No other guarantees or warranty, including warranty for fitness of products for in service operating condition shall exist in connection with sale of Antec products. Heat treatment after manufacture is not included unless specified.

Refractory Anchors

SB 2

Shelf Bracket (Single)

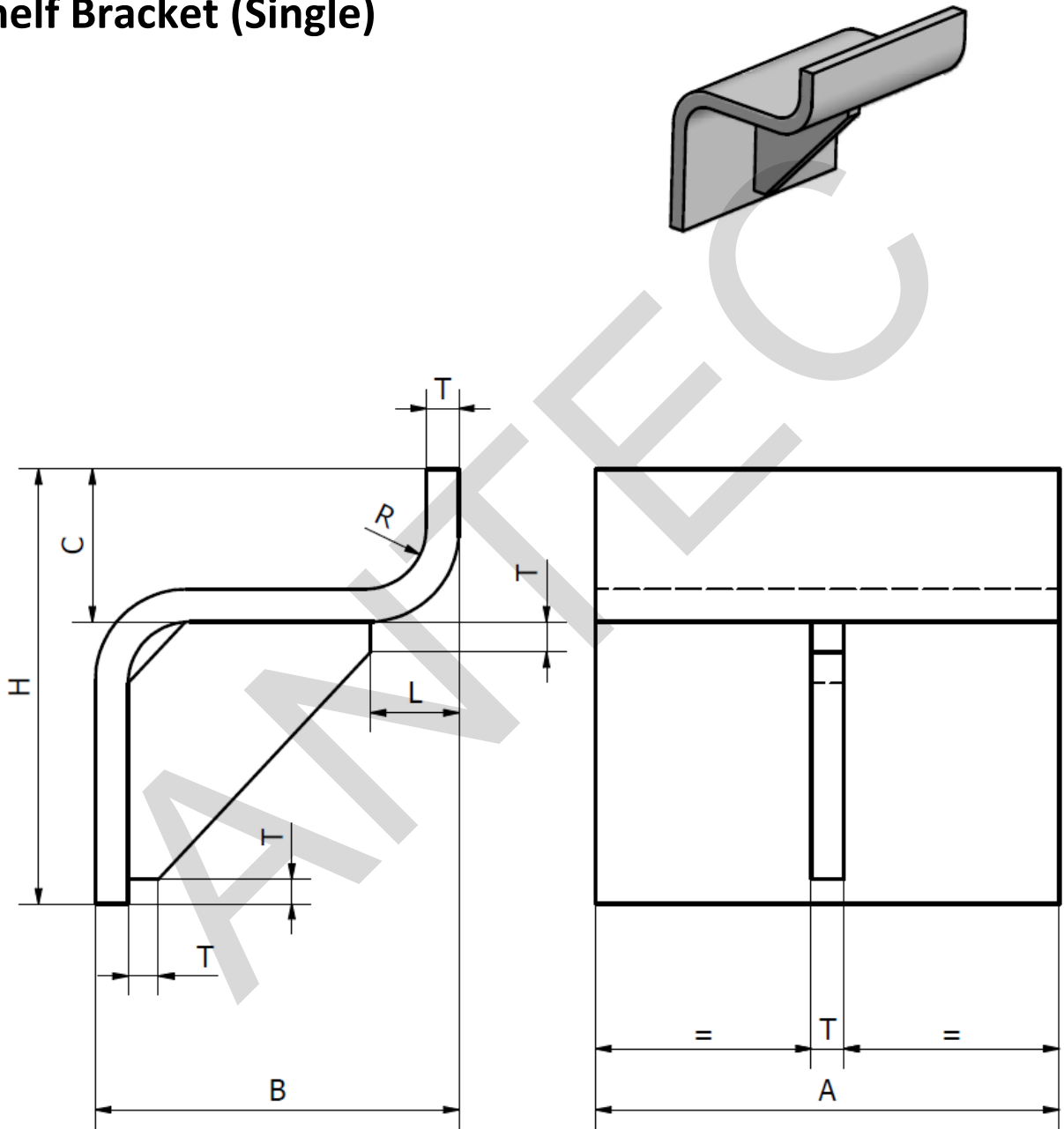

All items can be manufactured in various alloy steels.

Tolerances:

+/- 3mm on Dimensional

+/- 3° on Angular Dimensions

Unless otherwise noted.

This drawing is the property of Antec Group Pty Ltd and is supplied on the understanding it is not to be used for any purpose, copied or communicated to any other person without written permission of the proprietor. All rights are reserved for product design concept. Antec products are guaranteed to conform within normal commercial tolerance of the applicable description furnished and to be manufactured from material as specified. No other guarantees or warranty, including warranty for fitness of products for in service operating condition shall exist in connection with sale of Antec products. Heat treatment after manufacture is not included unless specified.

Hex Mesh & Punch Tabs

Hexmesh

Antec has been manufacturing hexagonal mesh for more than two decades, so we understand the strict performance and technical requirements that exist across a range of industries, including the major oil companies.

Whether you need standard size panels, custom-shapes or rolled products, Antec has the equipment, expertise and experience to meet your needs quickly and cost-effectively.

- Automated laser cut production facilities for speed and consistency
- Extensive selection of common shapes and sizes in stock including punch tabs
- Full in-house design and manufacturing for fast turnarounds on custom designs
- Range of stainless steel and carbon steel in stock and ready to go including alloy 304, 310, 253MA. Other materials can be supplied on request.
- Flexibility to deliver many specialty applications such as wear resistant materials
- Contact us for detailed drawings and specifications on our range

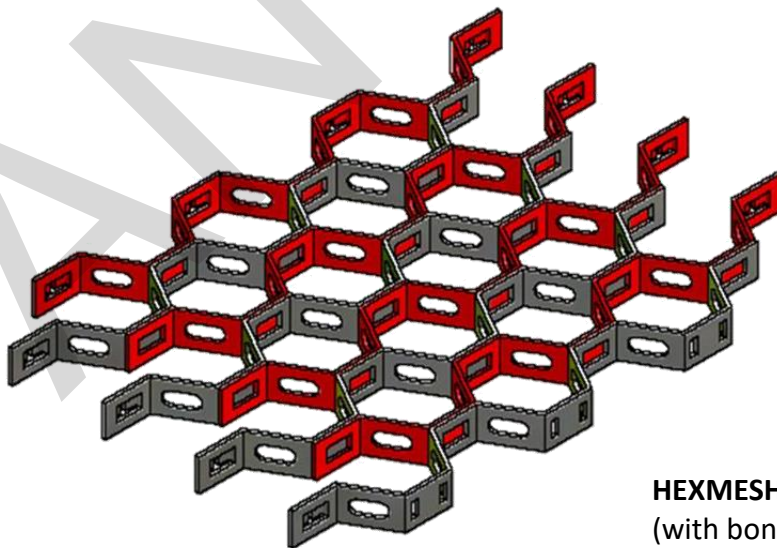

HEXMESH H TYPE
(with bonding holes)

This drawing is the property of Antec Group Pty Ltd and is supplied on the understanding it is not to be used for any purpose, copied or communicated to any other person without written permission of the proprietor. All rights are reserved for product design concept. Antec products are guaranteed to conform within normal commercial tolerance of the applicable description furnished and to be manufactured from material as specified. No other guarantees or warranty, including warranty for fitness of products for in service operating condition shall exist in connection with sale of Antec products. Heat treatment after manufacture is not included unless specified.



Hex Mesh & Punch Tabs

HEX 1

Antec Hexagonal Mesh

Unless specifically requested, all hexagonal mesh supplied by Antec will be manufactured with the stronger double clenched joining system as described below. An older style, using independent rivets to join the hex together is available, but must be specifically requested. Information on this older style can be supplied separately if needed.

All comments below are based on the doubled clenched joining system type. Hexmetal is manufactured in depths of 19mm, 25mm or 50mm with two different styles available:

1) Lance tab (L type) - this style has lance tabs protruding from the walls of the hexagonal cell to act as anchorage for the refractory. If the refractory is being gun applied the lances may cause a shadow effect with a void forming behind the lances.

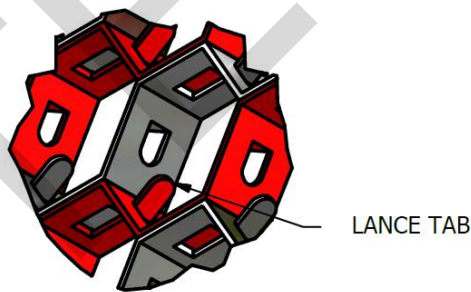
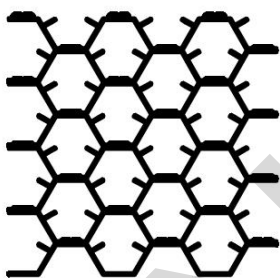

2) Bonding hole (H type) - instead of lance tabs, holes are punched through the walls of the hexmetal cell. Refractory can then flow through these holes to achieve a bond from one cell to another.

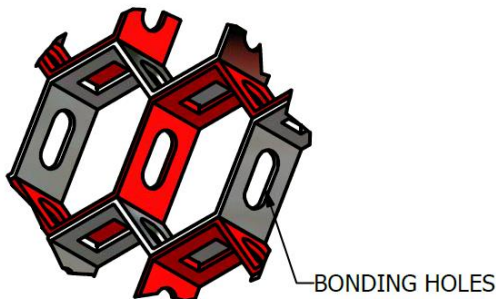
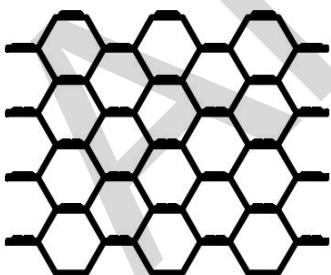

All hexmetal except 19mm is available as an offset or stepped type construction. The stepped type hexmetal has a shorter depth rib joining the full depth rib. Whilst both ribs are flush at the top surface, the shorter rib forms a gap on the back face. This gap at the back of the hexmetal allows the refractory to flow through it and hence creates a strong refractory bond between adjoining cells.

The 50mm deep hexmetal is only manufactured as stepped constructions.

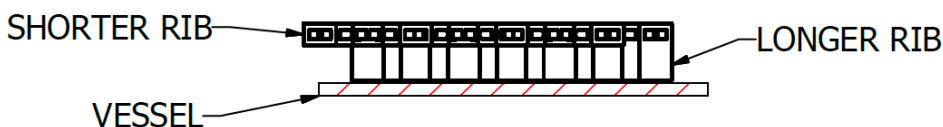

This drawing is the property of Antec Group Pty Ltd and is supplied on the understanding it is not to be used for any purpose, copied or communicated to any other person without written permission of the proprietor. All rights are reserved for product design concept. Antec products are guaranteed to conform within normal commercial tolerance of the applicable description furnished and to be manufactured from material as specified. No other guarantees or warranty, including warranty for fitness of products for in service operating condition shall exist in connection with sale of Antec products. Heat treatment after manufacture is not included unless specified.

Hex Mesh & Punch Tabs

HEX 2

Double Clench Joining System

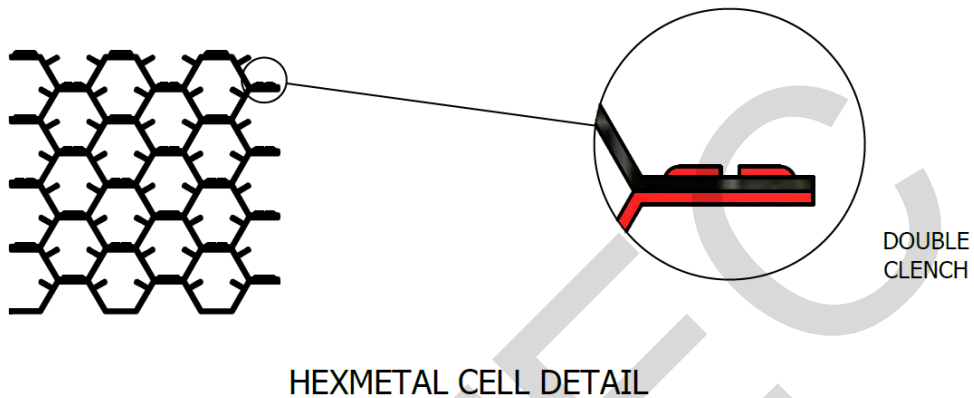

The most frequently supplied hexagonal mesh that Antec provides, is bonded by the unique double clenched holding system shown above. This type of bonding is widely recognised as providing a higher strength hexmetal.

A strong hex makes for a superior refractory lining.

A strong hexmetal keeps gaps between the adjoining hex rib to a minimum and also holds the panels of the hexmetal together more tightly when rolling to shape. Any small gaps (such as occur when rolling) cannot be adequately filled with refractory concrete. The non consolidated gap is then subject to ingress from the abrasive medium in the gas flow. The abrasive medium can ultimately track in behind the refractory/ hexmetal lining causing failure.

If hexagonal mesh is not tight and secure under operating conditions, the hex can "chatter" from vibration or any movement. This in turn can cause the refractory to crack or dislodge from the hexagonal cells.

When exposed to operating temperatures, the strength of the steel is significantly reduced. Therefore any additional strength incorporated into the fundamental design at ambient temperature will be of a greater benefit under the hot operating conditions.

Hex Mesh & Punch Tabs

HEX 3

Hexagonal Mesh Types

LANCE TAB TYPE	
L 19	Constant 19mm Rib Thickness
L 25	Constant 25mm Rib Thickness
L 25/19 (1:1)	25mm Stepped Hex with Every Alternate Rib 19mm
L 25/19 (1:3)	25mm Stepped Hex with 1 Rib x25mm then 3 x19mm
L 50/25 (1:1)	50mm Stepped Hex with Every Alternate Rib 25mm
L 50/25 (1:3)	50mm Stepped Hex with 1 Rib x50mm then 3 x25mm

BONDING HOLE TYPE	
H 19	Constant 19mm Rib Thickness
H 25	Constant 25mm Rib Thickness
H 25/19 (1:1)	25mm Stepped Hex with Every Alternate Rib 19mm
H 25/19 (1:3)	25mm Stepped Hex with 1 Rib x25mm then 3 x19mm
H 50/25 (1:1)	50mm Stepped Hex with Every Alternate Rib 25mm
H 50/25 (1:3)	50mm Stepped Hex with 1 Rib x50mm then 3 x25mm

Ratios and configurations can be varied to suit customers requirements.

Hex Mesh & Punch Tabs

HEX 4

Hexmesh Layout & Fixing Details

WELD FREQUENCY OF EVERY SECOND CELL, EVERY SECOND ROW

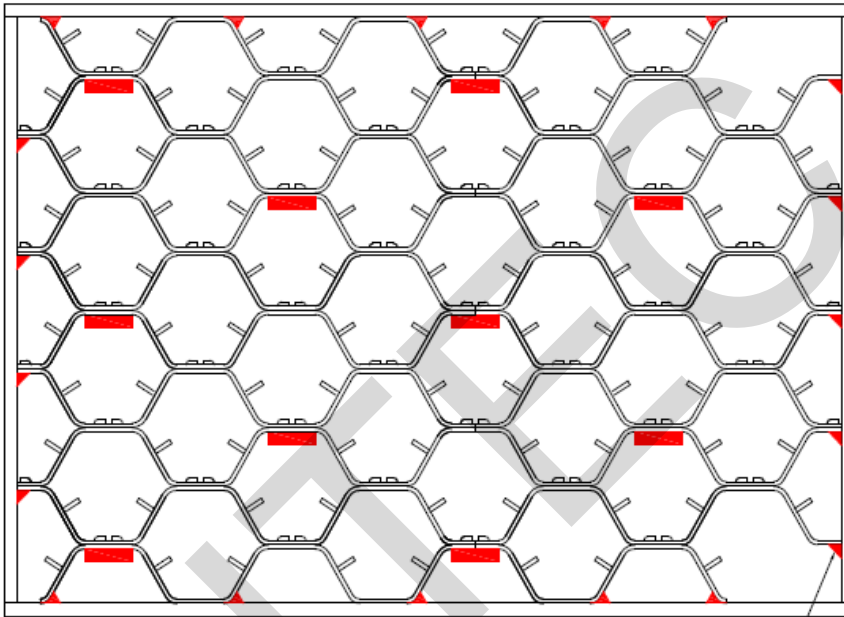

NOTE: IN ALL CIRCUMSTANCES THERE SHOULD NOT BE LESS THAN HALF A CELL AND NO GREATER THAN ONE & A HALF CELLS.

EVERY
END-RIB
WELDED

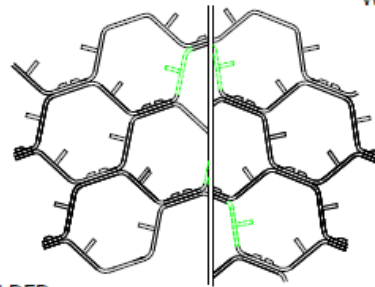
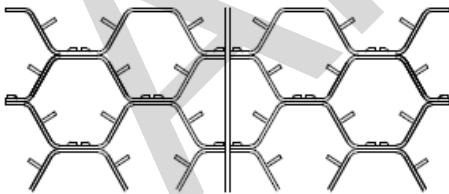

EVERY END-RIB WELDED

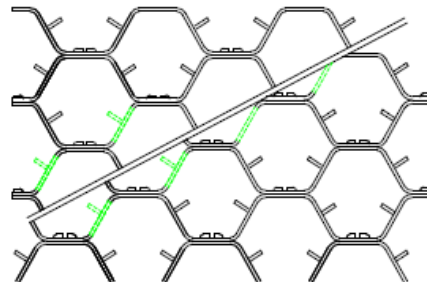
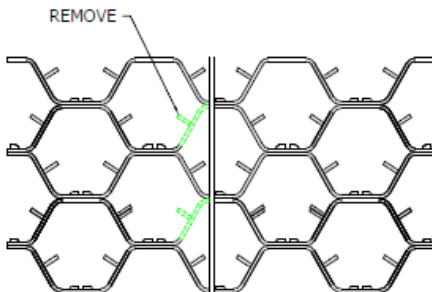

This drawing is the property of Antec Group Pty Ltd and is supplied on the understanding it is not to be used for any purpose, copied or communicated to any other person without written permission of the proprietor. All rights are reserved for product design concept. Antec products are guaranteed to conform within normal commercial tolerance of the applicable description furnished and to be manufactured from material as specified. No other guarantees or warranty, including warranty for fitness of products for in service operating condition shall exist in connection with sale of Antec products. Heat treatment after manufacture is not included unless specified.

Hex Mesh & Punch Tabs

HEX 5

Rolled Hex Section

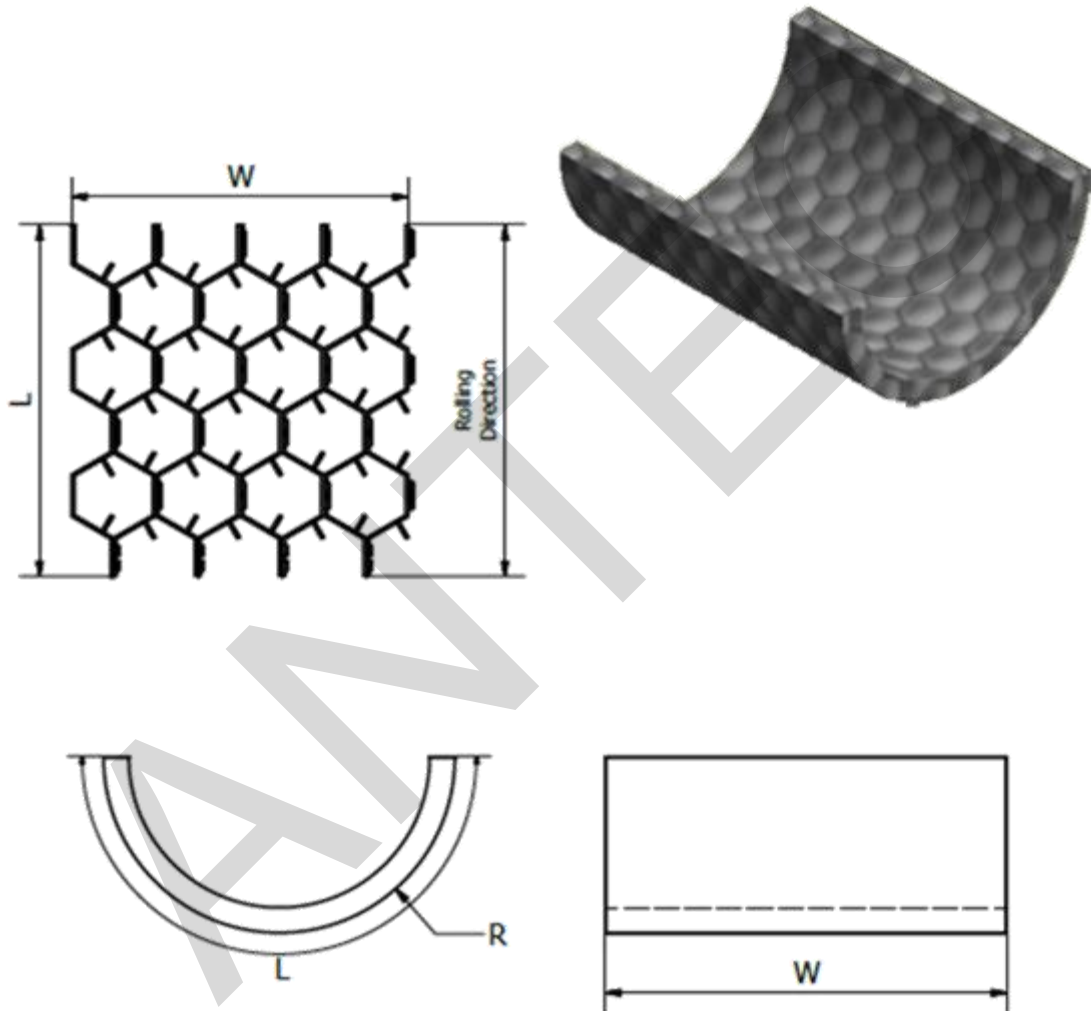

All items can be manufactured in various alloy steels.

Tolerances:

+/- 3mm on Dimensional

+/- 3° on Angular Dimensions

Unless otherwise noted.

This drawing is the property of Antec Group Pty Ltd and is supplied on the understanding it is not to be used for any purpose, copied or communicated to any other person without written permission of the proprietor. All rights are reserved for product design concept. Antec products are guaranteed to conform within normal commercial tolerance of the applicable description furnished and to be manufactured from material as specified. No other guarantees or warranty, including warranty for fitness of products for in service operating condition shall exist in connection with sale of Antec products. Heat treatment after manufacture is not included unless specified.

Hex Mesh & Punch Tabs

HEX 6

Rolled Cone Section

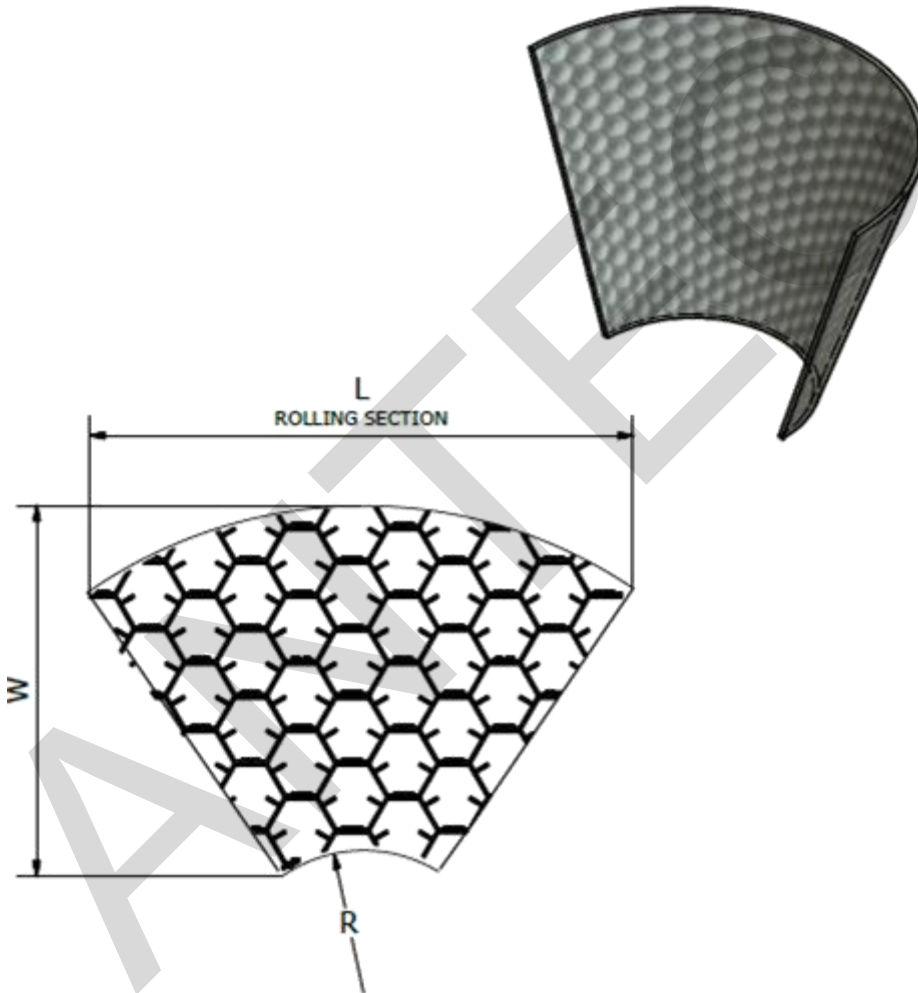

All items can be manufactured in various alloy steels.

Tolerances:

+/- 3mm on Dimensional

+/- 3° on Angular Dimensions

Unless otherwise noted.

This drawing is the property of Antec Group Pty Ltd and is supplied on the understanding it is not to be used for any purpose, copied or communicated to any other person without written permission of the proprietor. All rights are reserved for product design concept. Antec products are guaranteed to conform within normal commercial tolerance of the applicable description furnished and to be manufactured from material as specified. No other guarantees or warranty, including warranty for fitness of products for in service operating condition shall exist in connection with sale of Antec products. Heat treatment after manufacture is not included unless specified.

Hex Mesh & Punch Tabs

HEX 7

Rolled Dome Section

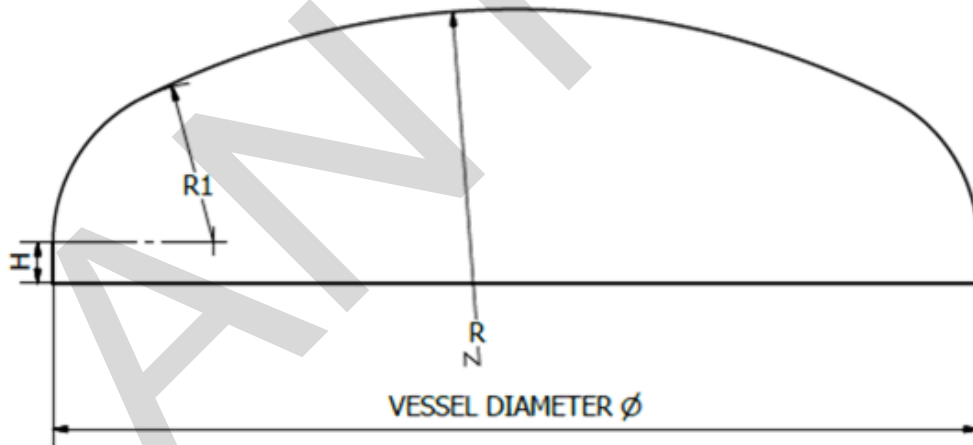

All items can be manufactured in various alloy steels.

Tolerances:

+/- 3mm on Dimensional

+/- 3° on Angular Dimensions

Unless otherwise noted.

This drawing is the property of Antec Group Pty Ltd and is supplied on the understanding it is not to be used for any purpose, copied or communicated to any other person without written permission of the proprietor. All rights are reserved for product design concept. Antec products are guaranteed to conform within normal commercial tolerance of the applicable description furnished and to be manufactured from material as specified. No other guarantees or warranty, including warranty for fitness of products for in service operating condition shall exist in connection with sale of Antec products. Heat treatment after manufacture is not included unless specified.

Hex Mesh & Punch Tabs

L 19

Hexmesh 19mm with Lance Tabs

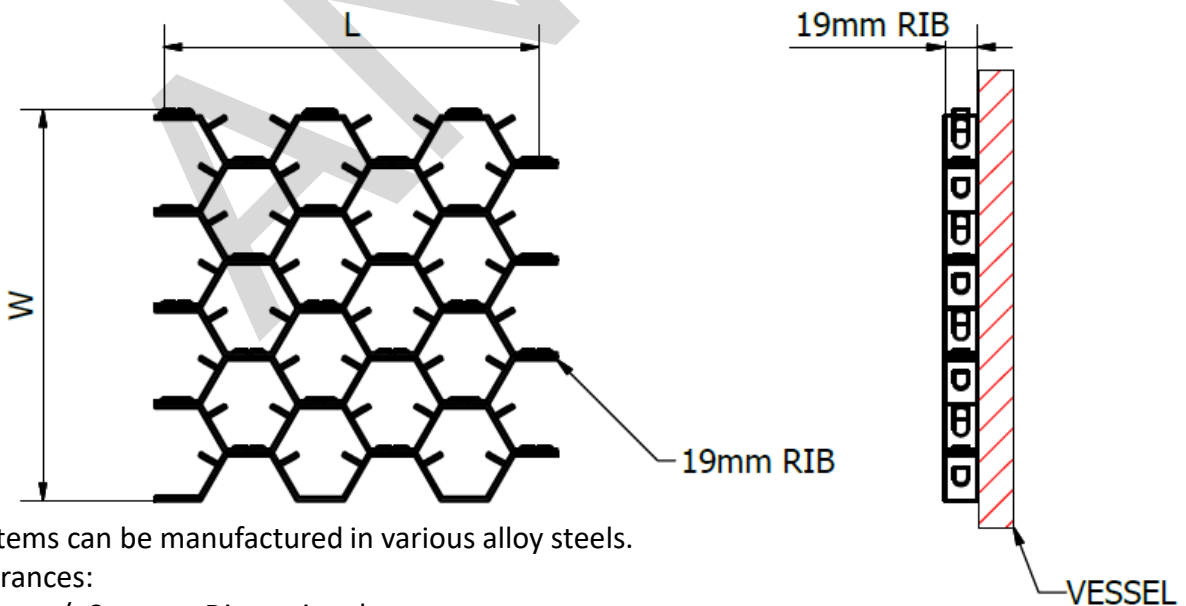
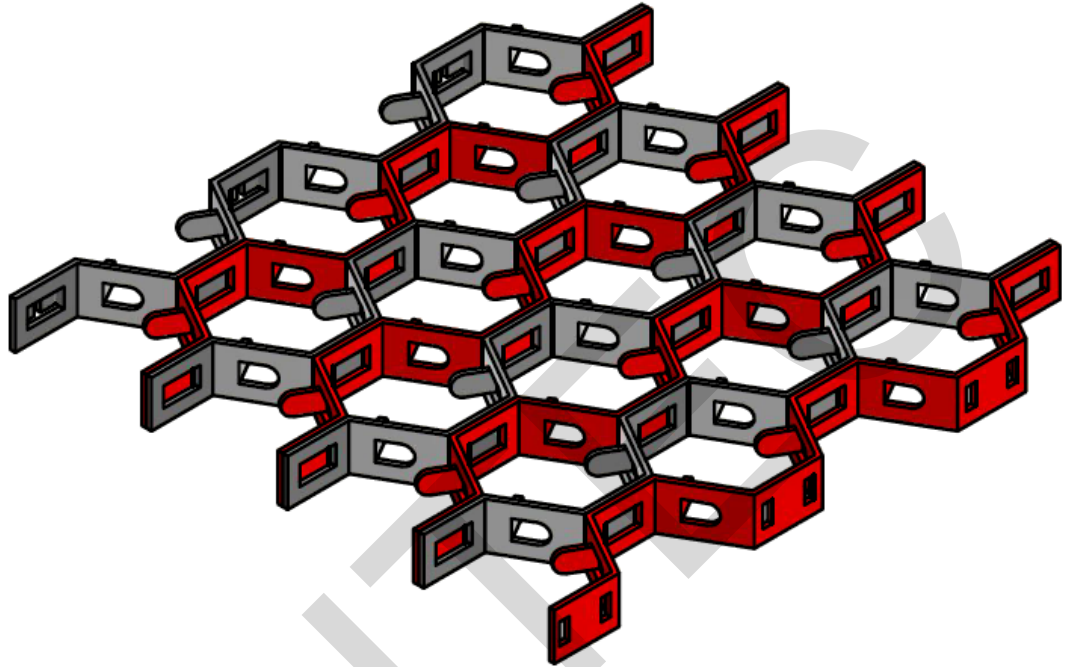

All items can be manufactured in various alloy steels.

Tolerances:

+/- 3mm on Dimensional

+/- 3° on Angular Dimensions

Unless otherwise noted.

This drawing is the property of Antec Group Pty Ltd and is supplied on the understanding it is not to be used for any purpose, copied or communicated to any other person without written permission of the proprietor. All rights are reserved for product design concept. Antec products are guaranteed to conform within normal commercial tolerance of the applicable description furnished and to be manufactured from material as specified. No other guarantees or warranty, including warranty for fitness of products for in service operating condition shall exist in connection with sale of Antec products. Heat treatment after manufacture is not included unless specified.

Hex Mesh & Punch Tabs

L 25

Hexmesh 25mm with Lance Tabs

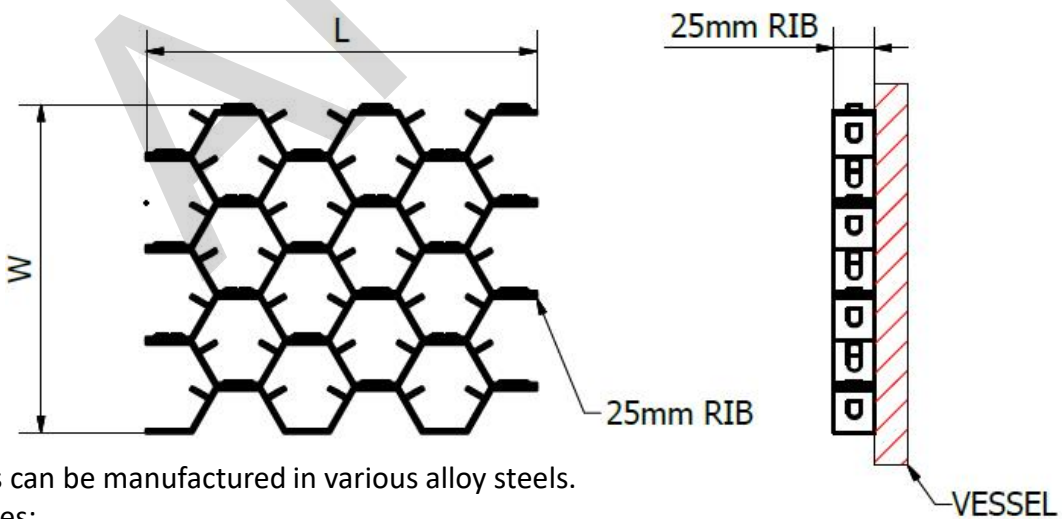
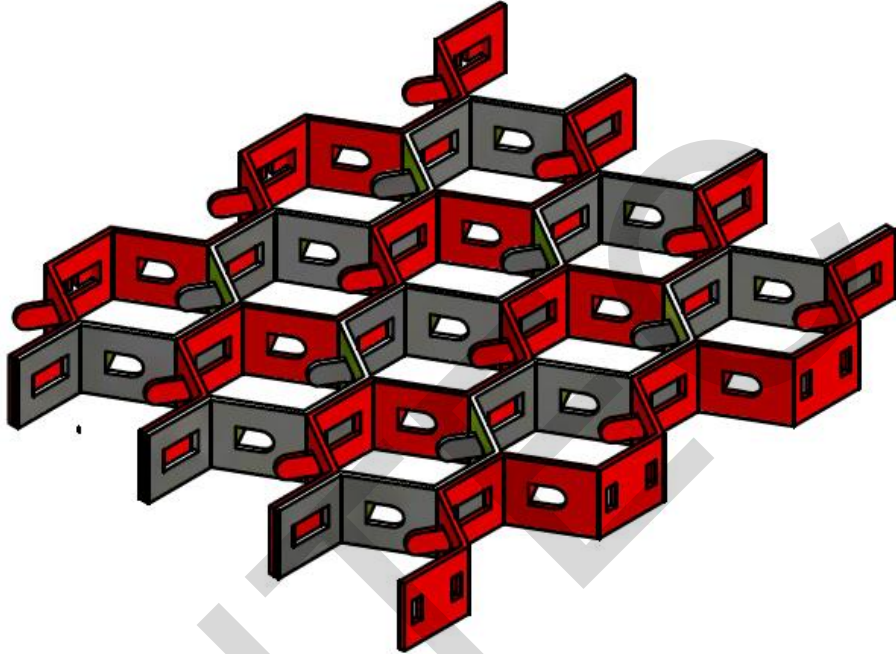

All items can be manufactured in various alloy steels.

Tolerances:

+/- 3mm on Dimensional

+/- 3° on Angular Dimensions

Unless otherwise noted.

This drawing is the property of Antec Group Pty Ltd and is supplied on the understanding it is not to be used for any purpose, copied or communicated to any other person without written permission of the proprietor. All rights are reserved for product design concept. Antec products are guaranteed to conform within normal commercial tolerance of the applicable description furnished and to be manufactured from material as specified. No other guarantees or warranty, including warranty for fitness of products for in service operating condition shall exist in connection with sale of Antec products. Heat treatment after manufacture is not included unless specified.

Hex Mesh & Punch Tabs

L 25-19

Step Hexmesh 25-19mm with Lance Tabs

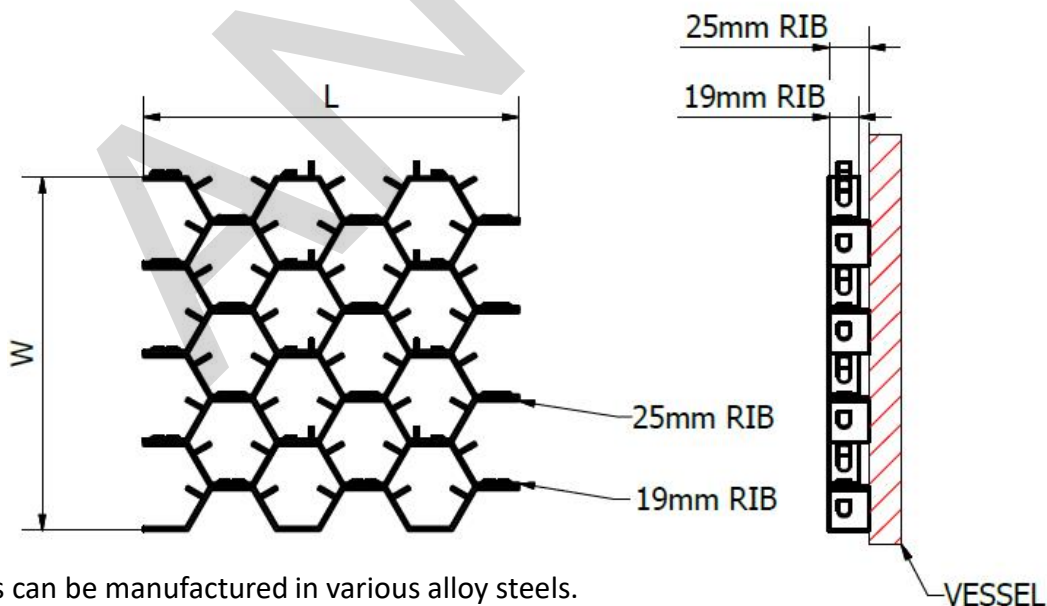

All items can be manufactured in various alloy steels.

Tolerances:

+/- 3mm on Dimensional

+/- 3° on Angular Dimensions

Unless otherwise noted.

This drawing is the property of Antec Group Pty Ltd and is supplied on the understanding it is not to be used for any purpose, copied or communicated to any other person without written permission of the proprietor. All rights are reserved for product design concept. Antec products are guaranteed to conform within normal commercial tolerance of the applicable description furnished and to be manufactured from material as specified. No other guarantees or warranty, including warranty for fitness of products for in service operating condition shall exist in connection with sale of Antec products. Heat treatment after manufacture is not included unless specified.

Hex Mesh & Punch Tabs

H 19

Hexmesh 19mm with Bonding Holes

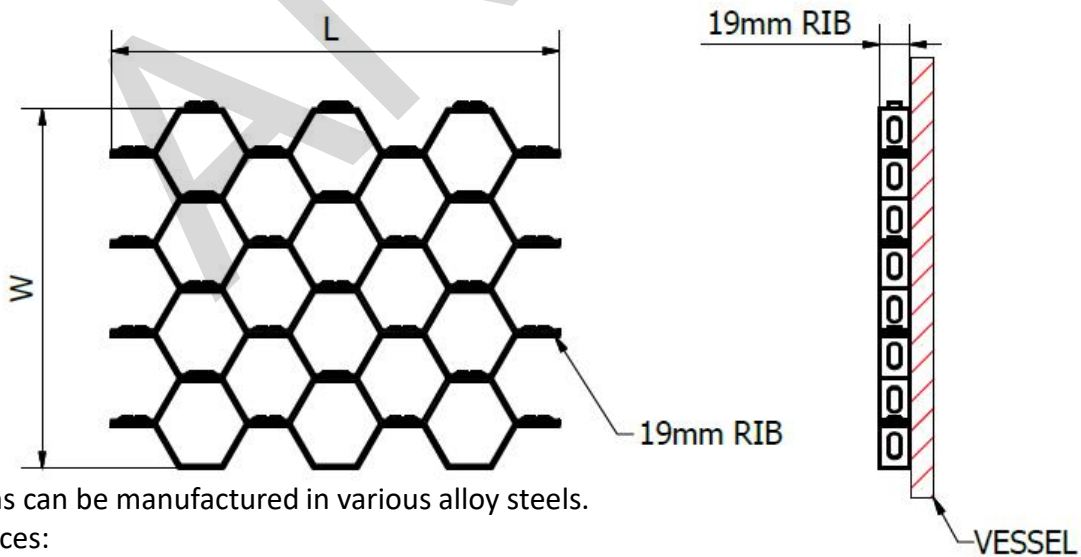
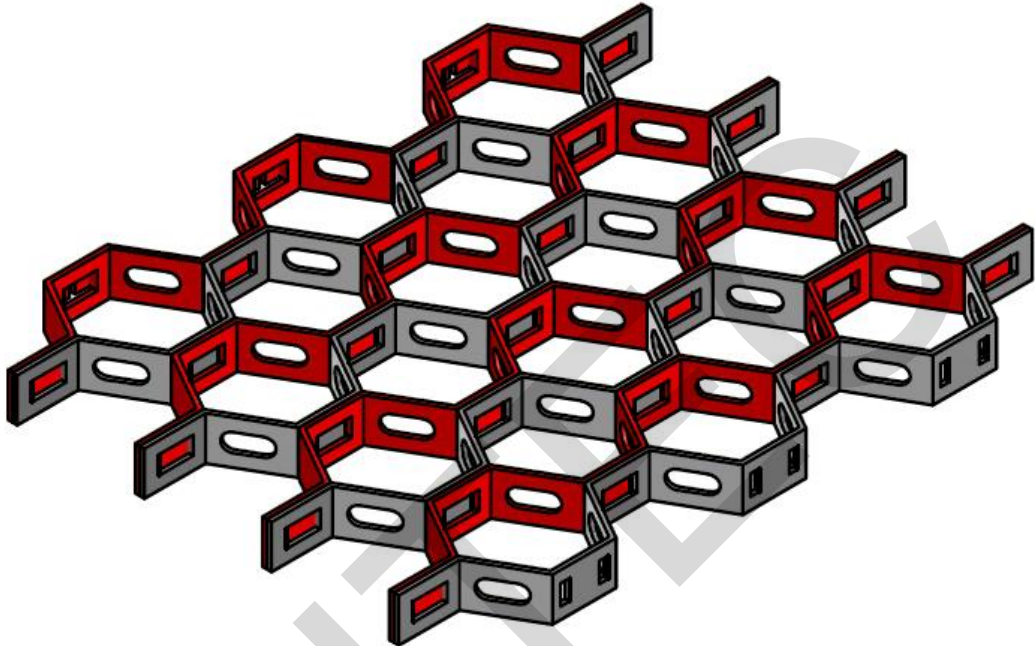

All items can be manufactured in various alloy steels.

Tolerances:

+/- 3mm on Dimensional

+/- 3° on Angular Dimensions

Unless otherwise noted.

This drawing is the property of Antec Group Pty Ltd and is supplied on the understanding it is not to be used for any purpose, copied or communicated to any other person without written permission of the proprietor. All rights are reserved for product design concept. Antec products are guaranteed to conform within normal commercial tolerance of the applicable description furnished and to be manufactured from material as specified. No other guarantees or warranty, including warranty for fitness of products for in service operating condition shall exist in connection with sale of Antec products. Heat treatment after manufacture is not included unless specified.

Hex Mesh & Punch Tabs

H 25

Hexmesh 25mm with Bonding Holes

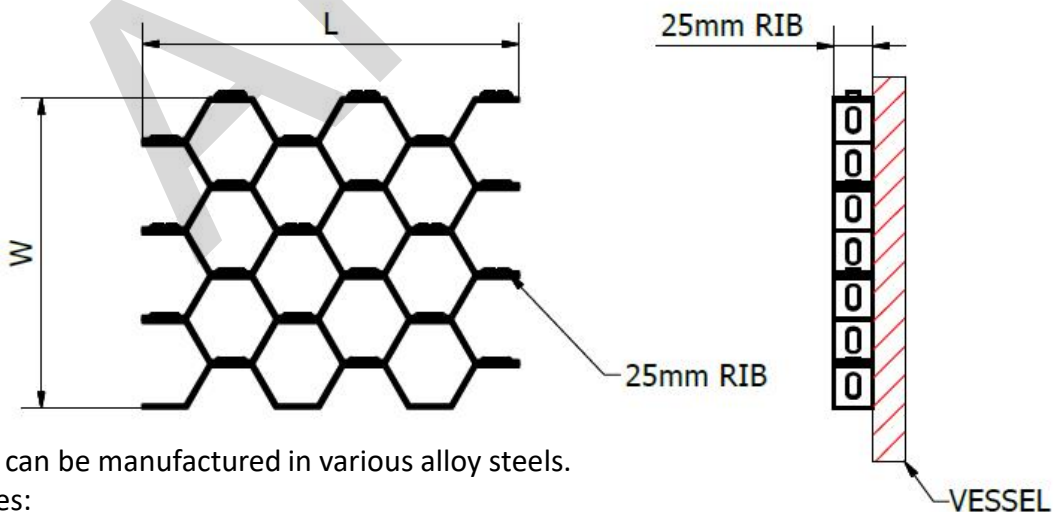
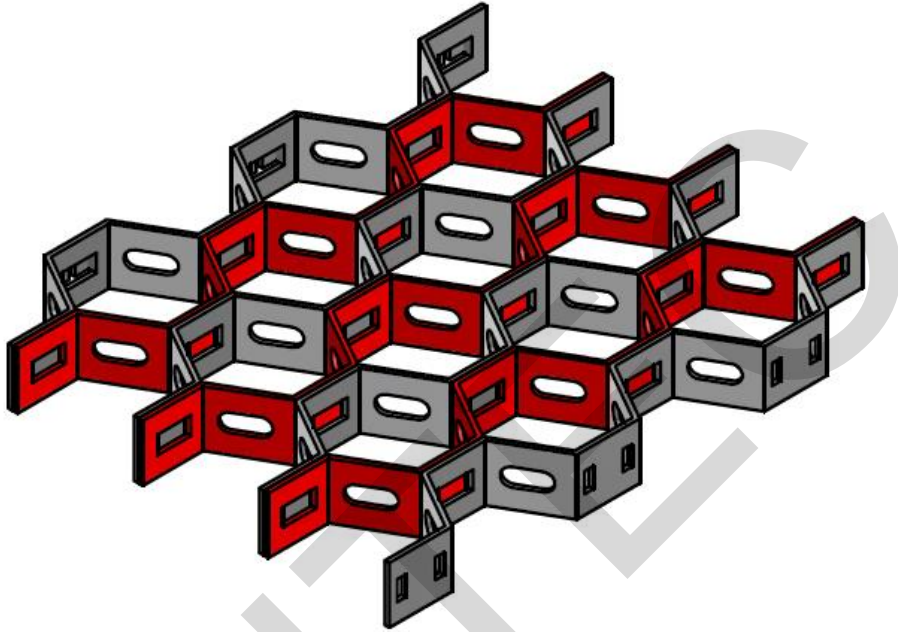

All items can be manufactured in various alloy steels.

Tolerances:

+/- 3mm on Dimensional

+/- 3° on Angular Dimensions

Unless otherwise noted.

This drawing is the property of Antec Group Pty Ltd and is supplied on the understanding it is not to be used for any purpose, copied or communicated to any other person without written permission of the proprietor. All rights are reserved for product design concept. Antec products are guaranteed to conform within normal commercial tolerance of the applicable description furnished and to be manufactured from material as specified. No other guarantees or warranty, including warranty for fitness of products for in service operating condition shall exist in connection with sale of Antec products. Heat treatment after manufacture is not included unless specified.

Hex Mesh & Punch Tabs

H 25-19

Hexmesh 25-19mm with Bonding Holes

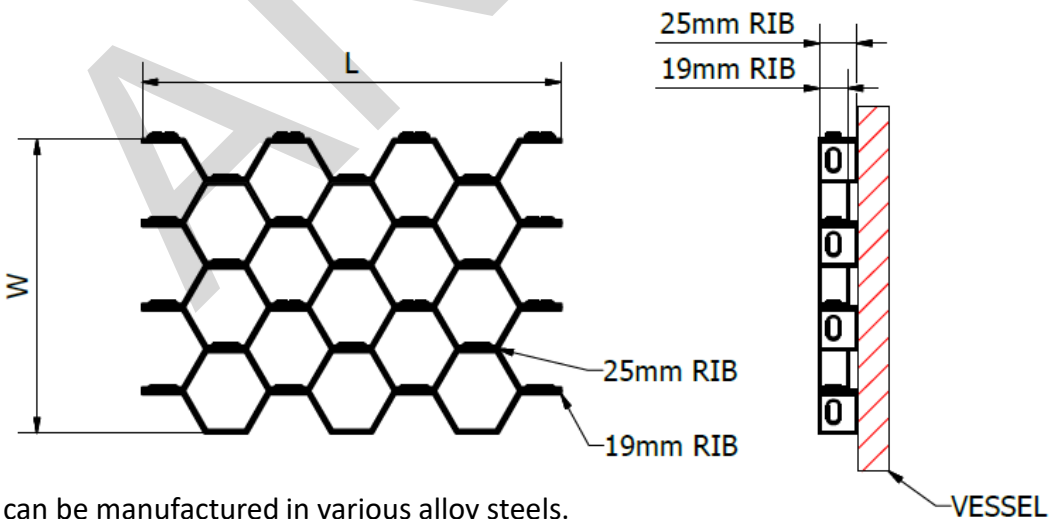
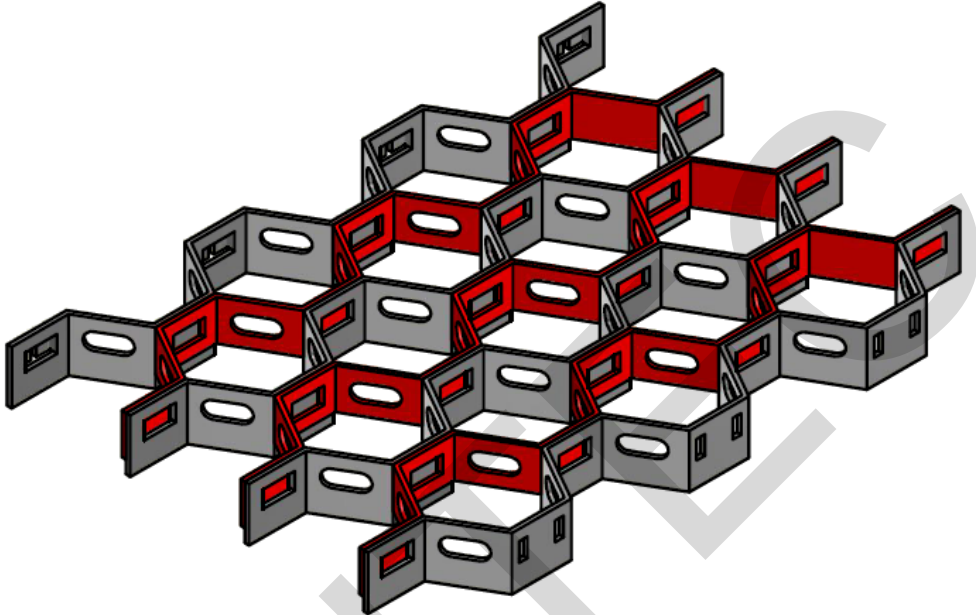

All items can be manufactured in various alloy steels.

Tolerances:

+/- 3mm on Dimensional

+/- 3° on Angular Dimensions

Unless otherwise noted.

This drawing is the property of Antec Group Pty Ltd and is supplied on the understanding it is not to be used for any purpose, copied or communicated to any other person without written permission of the proprietor. All rights are reserved for product design concept. Antec products are guaranteed to conform within normal commercial tolerance of the applicable description furnished and to be manufactured from material as specified. No other guarantees or warranty, including warranty for fitness of products for in service operating condition shall exist in connection with sale of Antec products. Heat treatment after manufacture is not included unless specified.

Hex Mesh & Punch Tabs

H 50

Hexmesh 50mm with Bonding Holes

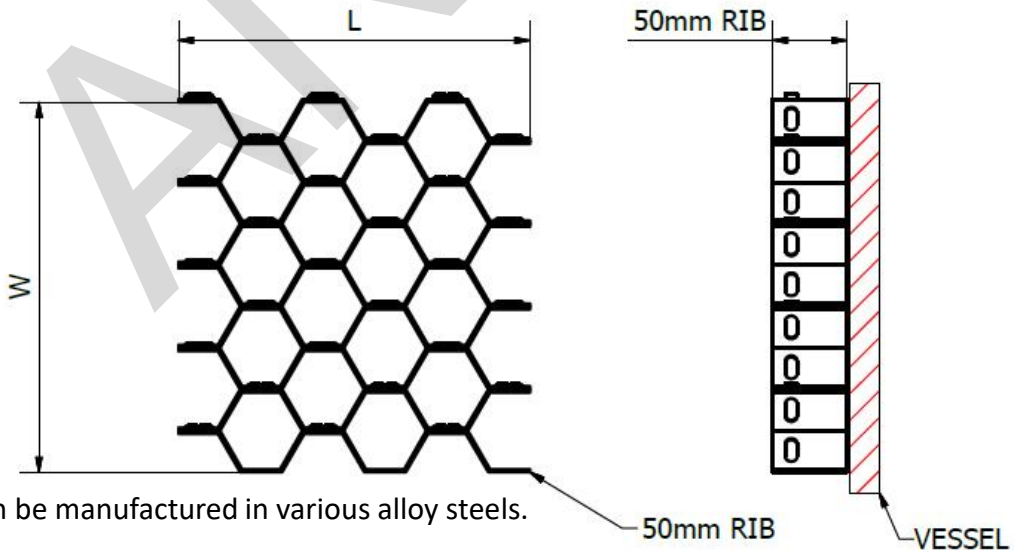
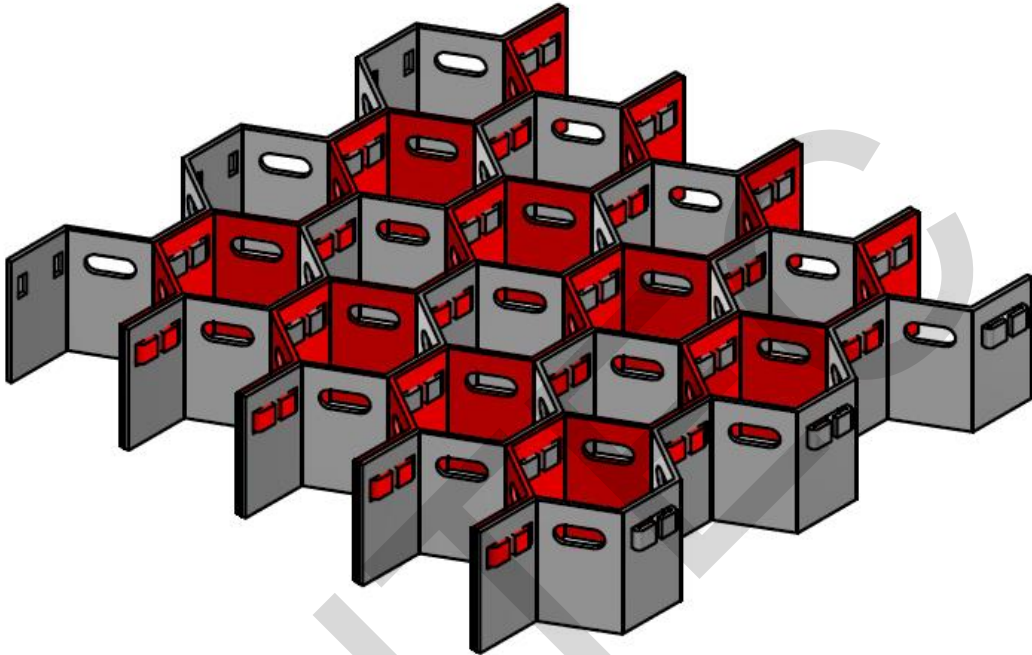

All items can be manufactured in various alloy steels.

Tolerances:

+/- 3mm on Dimensional

+/- 3° on Angular Dimensions

Unless otherwise noted.

This drawing is the property of Antec Group Pty Ltd and is supplied on the understanding it is not to be used for any purpose, copied or communicated to any other person without written permission of the proprietor. All rights are reserved for product design concept. Antec products are guaranteed to conform within normal commercial tolerance of the applicable description furnished and to be manufactured from material as specified. No other guarantees or warranty, including warranty for fitness of products for in service operating condition shall exist in connection with sale of Antec products. Heat treatment after manufacture is not included unless specified.

Hex Mesh & Punch Tabs

H 50-25

Step Hexmesh 50-25mm with Bonding Holes (1:1)

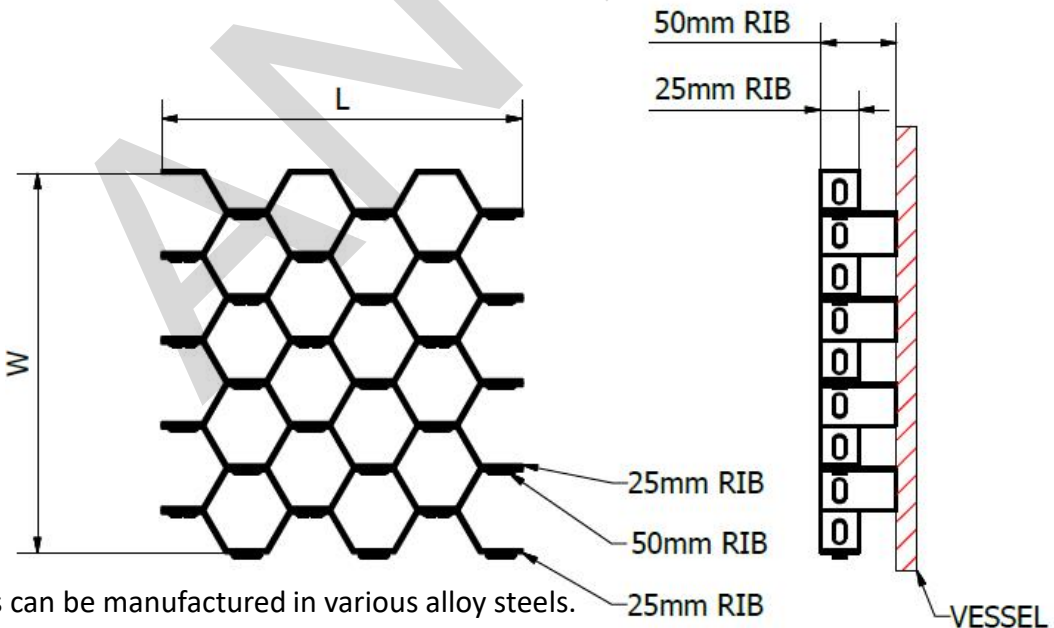
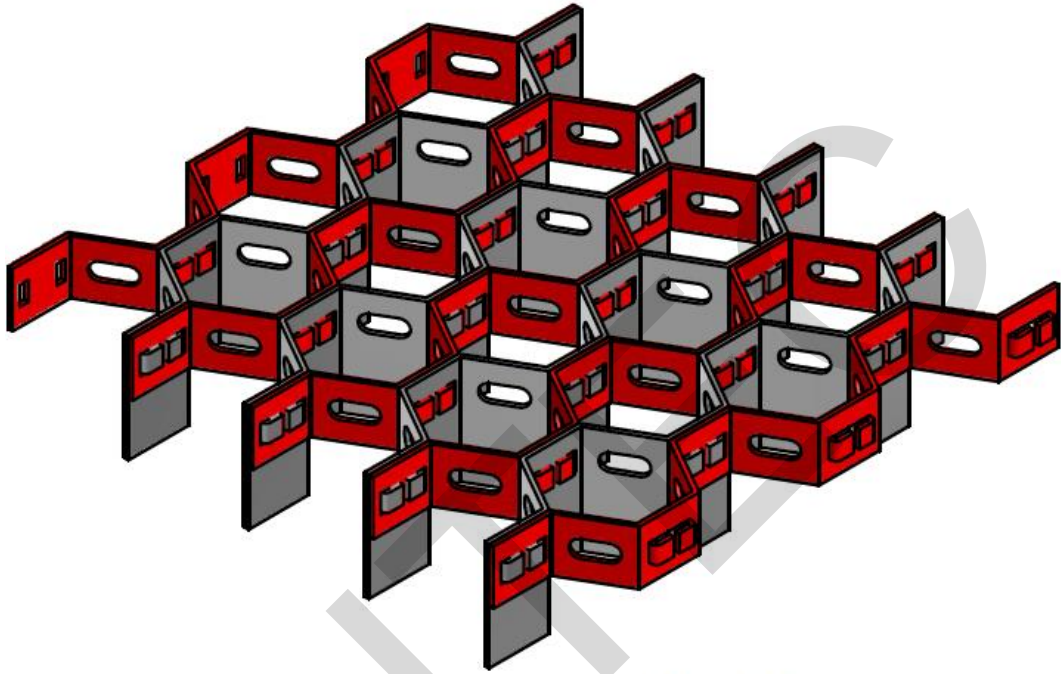

All items can be manufactured in various alloy steels.

Tolerances:

+/- 3mm on Dimensional

+/- 3° on Angular Dimensions

Unless otherwise noted.

This drawing is the property of Antec Group Pty Ltd and is supplied on the understanding it is not to be used for any purpose, copied or communicated to any other person without written permission of the proprietor. All rights are reserved for product design concept. Antec products are guaranteed to conform within normal commercial tolerance of the applicable description furnished and to be manufactured from material as specified. No other guarantees or warranty, including warranty for fitness of products for in service operating condition shall exist in connection with sale of Antec products. Heat treatment after manufacture is not included unless specified.

Hex Mesh & Punch Tabs

H 50-25

Step Hexmesh 50-25mm with Bonding Holes (1:3)

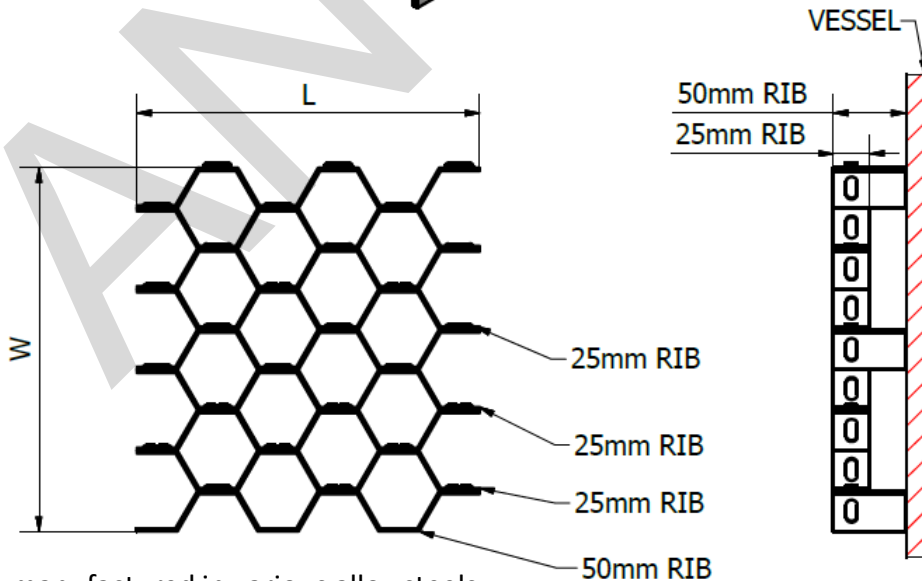
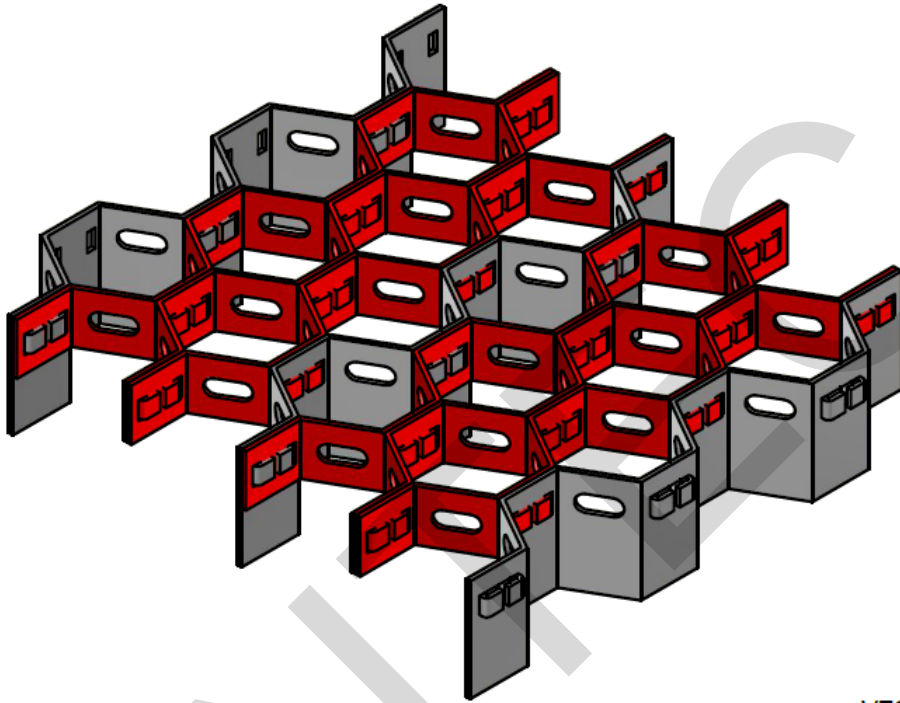

All items can be manufactured in various alloy steels.

Tolerances:

+/- 3mm on Dimensional

+/- 3° on Angular Dimensions

Unless otherwise noted.

This drawing is the property of Antec Group Pty Ltd and is supplied on the understanding it is not to be used for any purpose, copied or communicated to any other person without written permission of the proprietor. All rights are reserved for product design concept. Antec products are guaranteed to conform within normal commercial tolerance of the applicable description furnished and to be manufactured from material as specified. No other guarantees or warranty, including warranty for fitness of products for in service operating condition shall exist in connection with sale of Antec products. Heat treatment after manufacture is not included unless specified.

Hex Mesh & Punch Tabs

PT 1

Punch Tabs

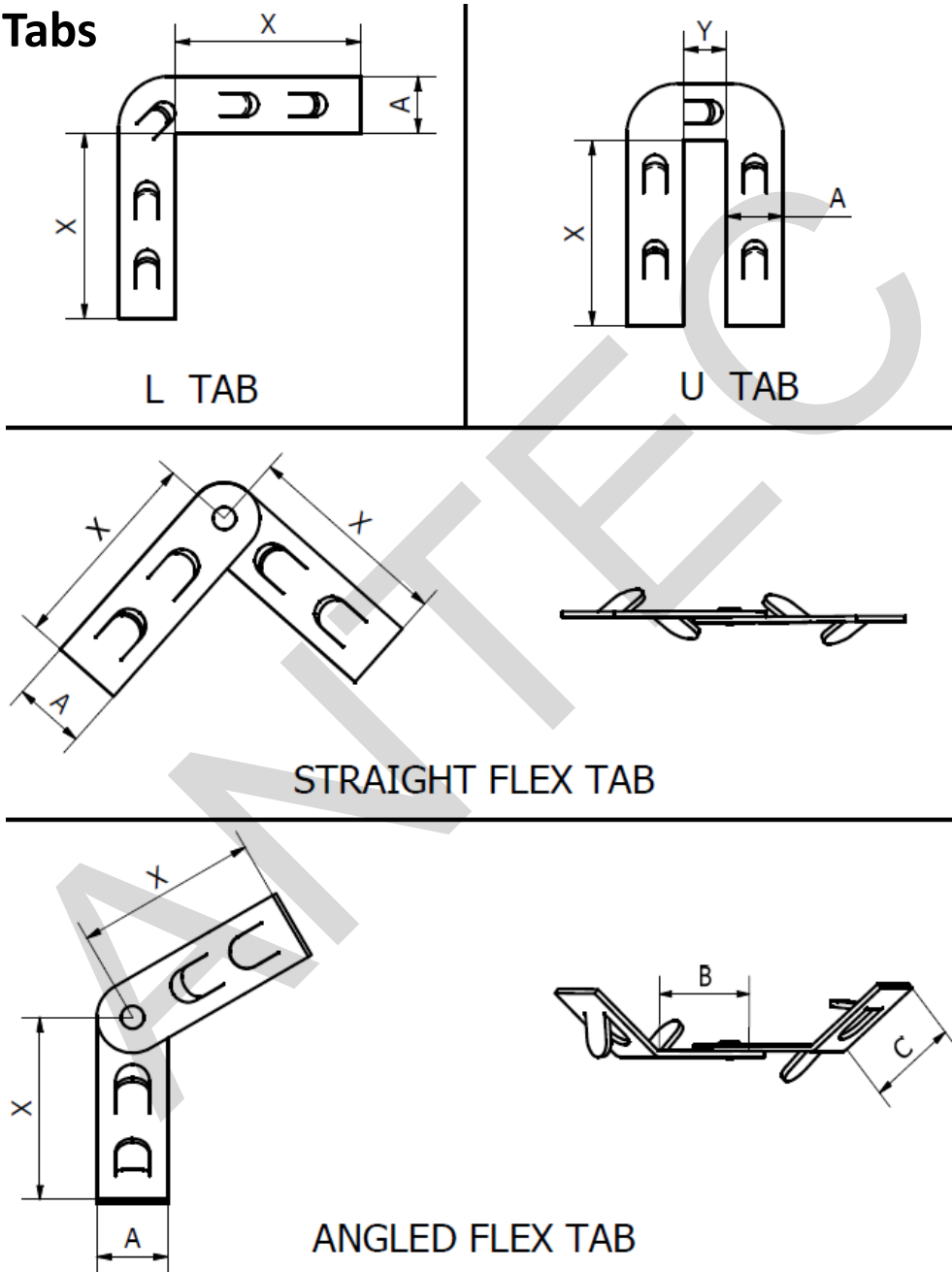

All items can be manufactured in various alloy steels.

Tolerances:

+/- 3mm on Dimensional

+/- 3° on Angular Dimensions

Unless otherwise noted.

This drawing is the property of Antec Group Pty Ltd and is supplied on the understanding it is not to be used for any purpose, copied or communicated to any other person without written permission of the proprietor. All rights are reserved for product design concept. Antec products are guaranteed to conform within normal commercial tolerance of the applicable description furnished and to be manufactured from material as specified. No other guarantees or warranty, including warranty for fitness of products for in service operating condition shall exist in connection with sale of Antec products. Heat treatment after manufacture is not included unless specified.

Hex Mesh & Punch Tabs

PT 2

Typical Hexmetal Corner Details

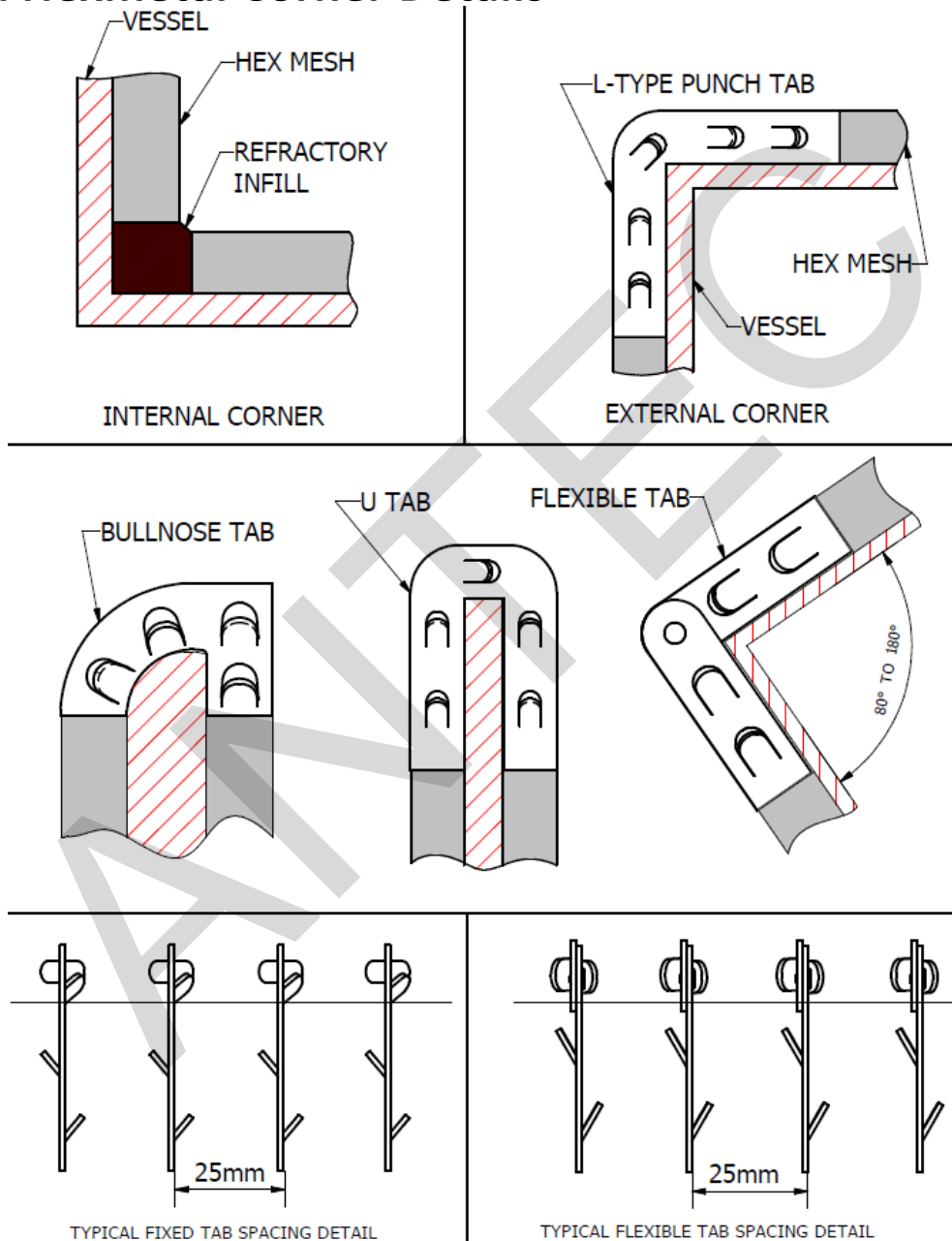

All items can be manufactured in various alloy steels.

Tolerances:

+/- 3mm on Dimensional

+/- 3° on Angular Dimensions

Unless otherwise noted.

This drawing is the property of Antec Group Pty Ltd and is supplied on the understanding it is not to be used for any purpose, copied or communicated to any other person without written permission of the proprietor. All rights are reserved for product design concept. Antec products are guaranteed to conform within normal commercial tolerance of the applicable description furnished and to be manufactured from material as specified. No other guarantees or warranty, including warranty for fitness of products for in service operating condition shall exist in connection with sale of Antec products. Heat treatment after manufacture is not included unless specified.

Hex Mesh & Punch Tabs

PT 3

Radius Corner Tab

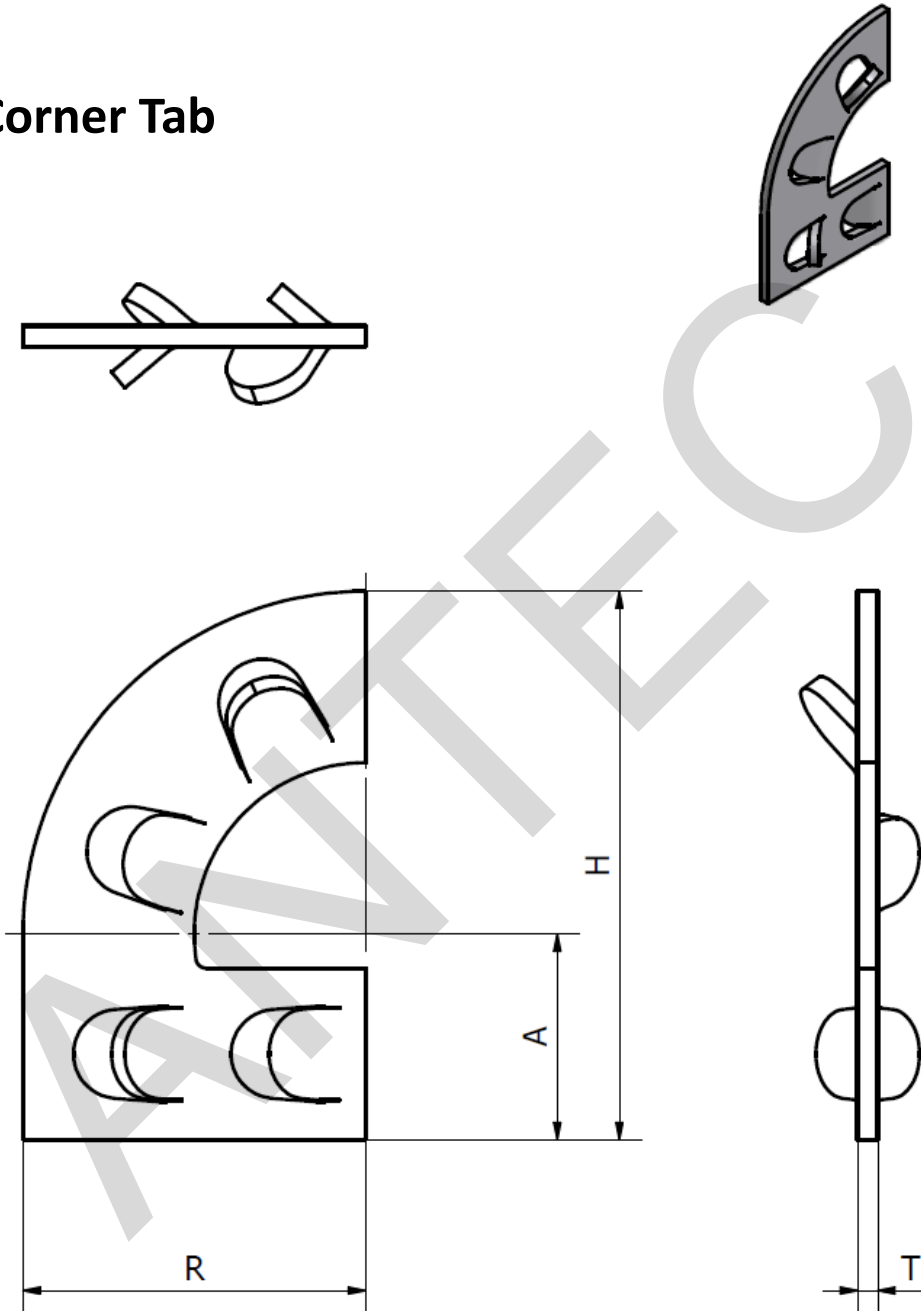

All items can be manufactured in various alloy steels.

Shape, spacing, size and orientation of tabs to be specified by customer.

Tolerances:

+/- 3mm on Dimensional

+/- 3° on Angular Dimensions

Unless otherwise noted.

Tabs as drawn are diagrammatic only.

This drawing is the property of Antec Group Pty Ltd and is supplied on the understanding it is not to be used for any purpose, copied or communicated to any other person without written permission of the proprietor. All rights are reserved for product design concept. Antec products are guaranteed to conform within normal commercial tolerance of the applicable description furnished and to be manufactured from material as specified. No other guarantees or warranty, including warranty for fitness of products for in service operating condition shall exist in connection with sale of Antec products. Heat treatment after manufacture is not included unless specified.

Hex Mesh & Punch Tabs

PT 4

Corner Tab

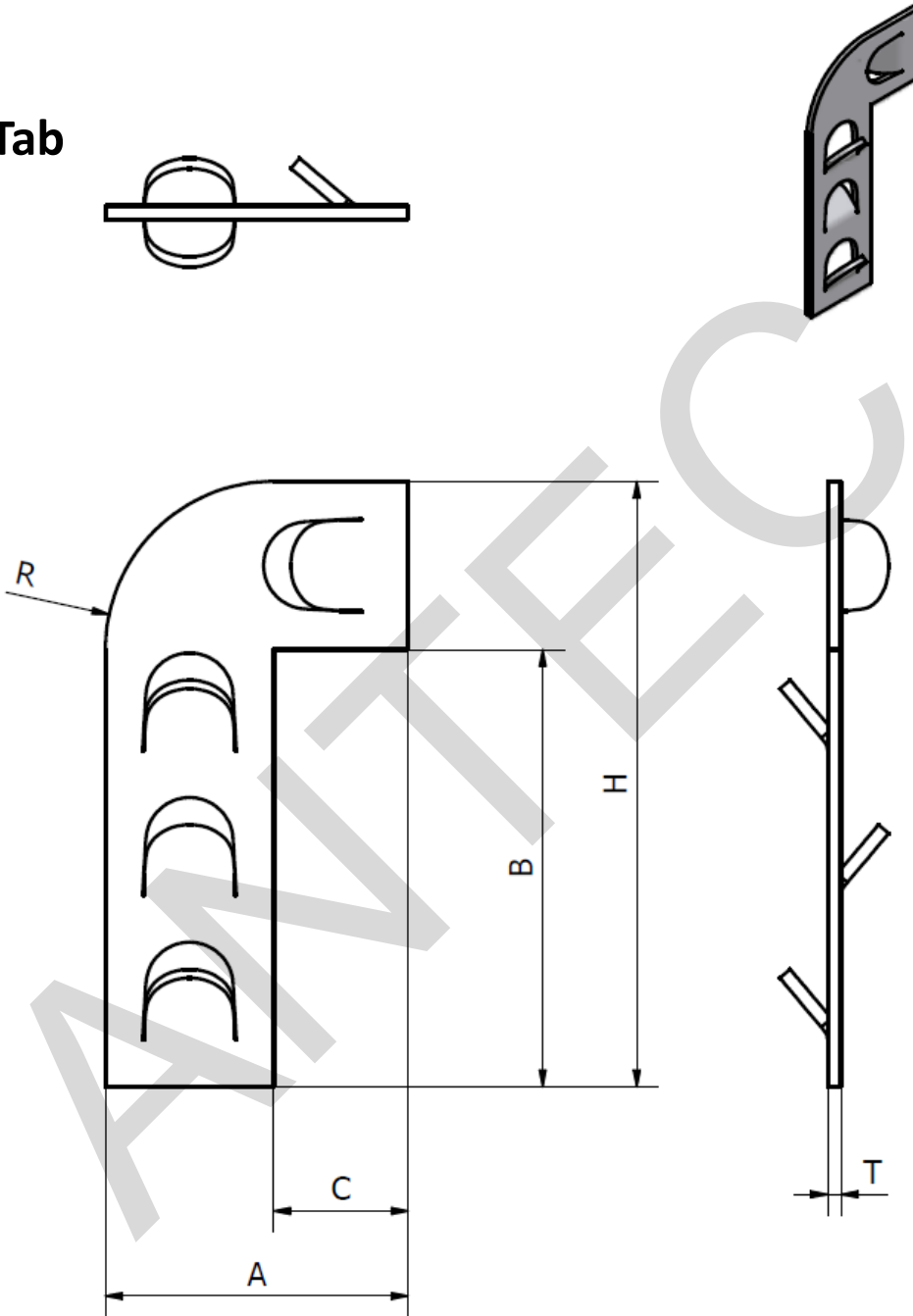

All items can be manufactured in various alloy steels.

Shape, spacing, size and orientation of tabs to be specified by customer.

Tolerances:

+/- 3mm on Dimensional

+/- 3° on Angular Dimensions

Unless otherwise noted.

Tabs as drawn are diagrammatic only.

This drawing is the property of Antec Group Pty Ltd and is supplied on the understanding it is not to be used for any purpose, copied or communicated to any other person without written permission of the proprietor. All rights are reserved for product design concept. Antec products are guaranteed to conform within normal commercial tolerance of the applicable description furnished and to be manufactured from material as specified. No other guarantees or warranty, including warranty for fitness of products for in service operating condition shall exist in connection with sale of Antec products. Heat treatment after manufacture is not included unless specified.

Hex Mesh & Punch Tabs

PT 5

Raised Corner Tab

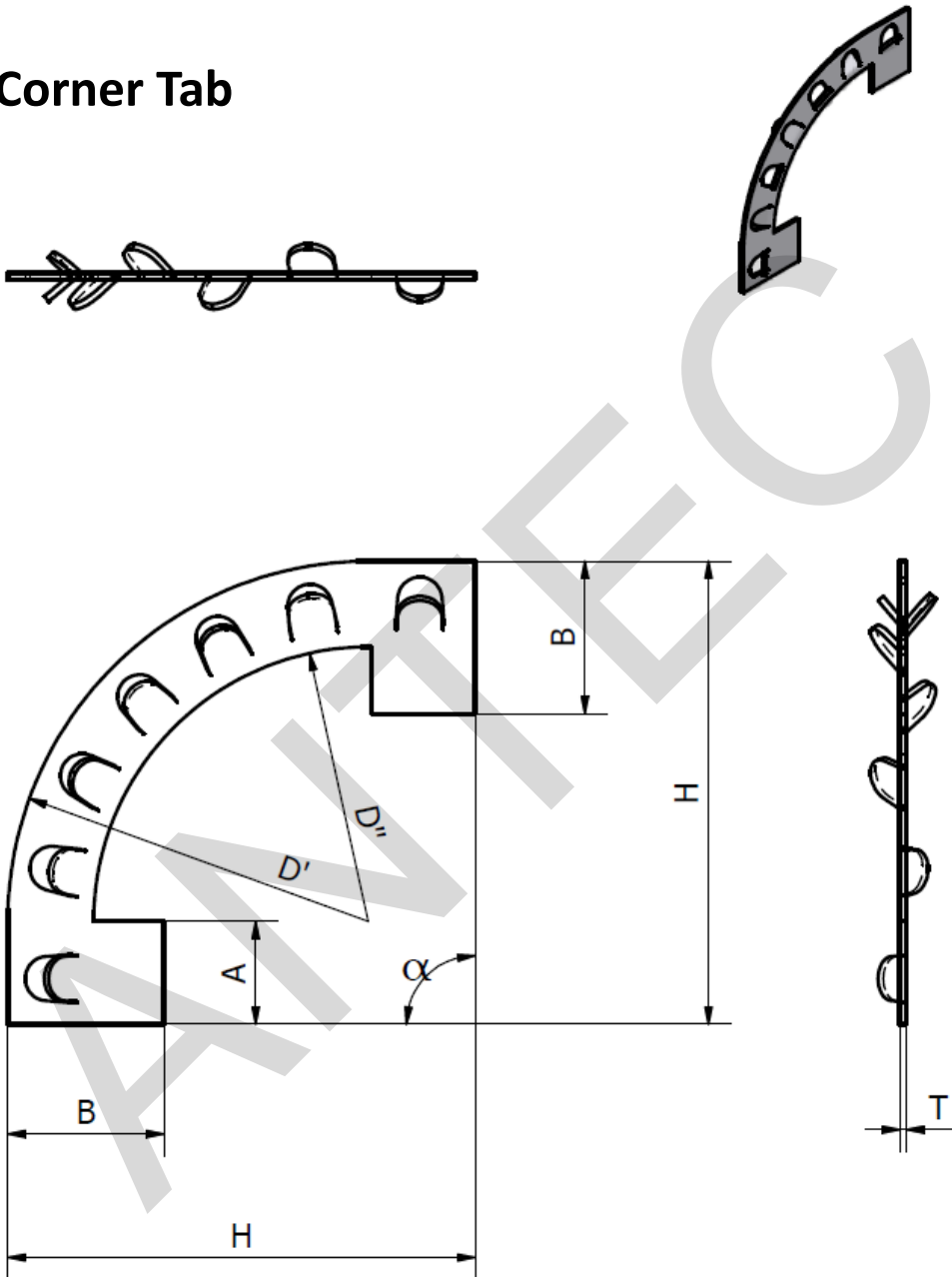

All items can be manufactured in various alloy steels.

Shape, spacing, size and orientation of tabs to be specified by customer.

Tolerances:

+/- 3mm on Dimensional

+/- 3° on Angular Dimensions

Unless otherwise noted.

Tabs as drawn are diagrammatic only.

This drawing is the property of Antec Group Pty Ltd and is supplied on the understanding it is not to be used for any purpose, copied or communicated to any other person without written permission of the proprietor. All rights are reserved for product design concept. Antec products are guaranteed to conform within normal commercial tolerance of the applicable description furnished and to be manufactured from material as specified. No other guarantees or warranty, including warranty for fitness of products for in service operating condition shall exist in connection with sale of Antec products. Heat treatment after manufacture is not included unless specified.

Hex Mesh & Punch Tabs

PT 6

Pipe Tab

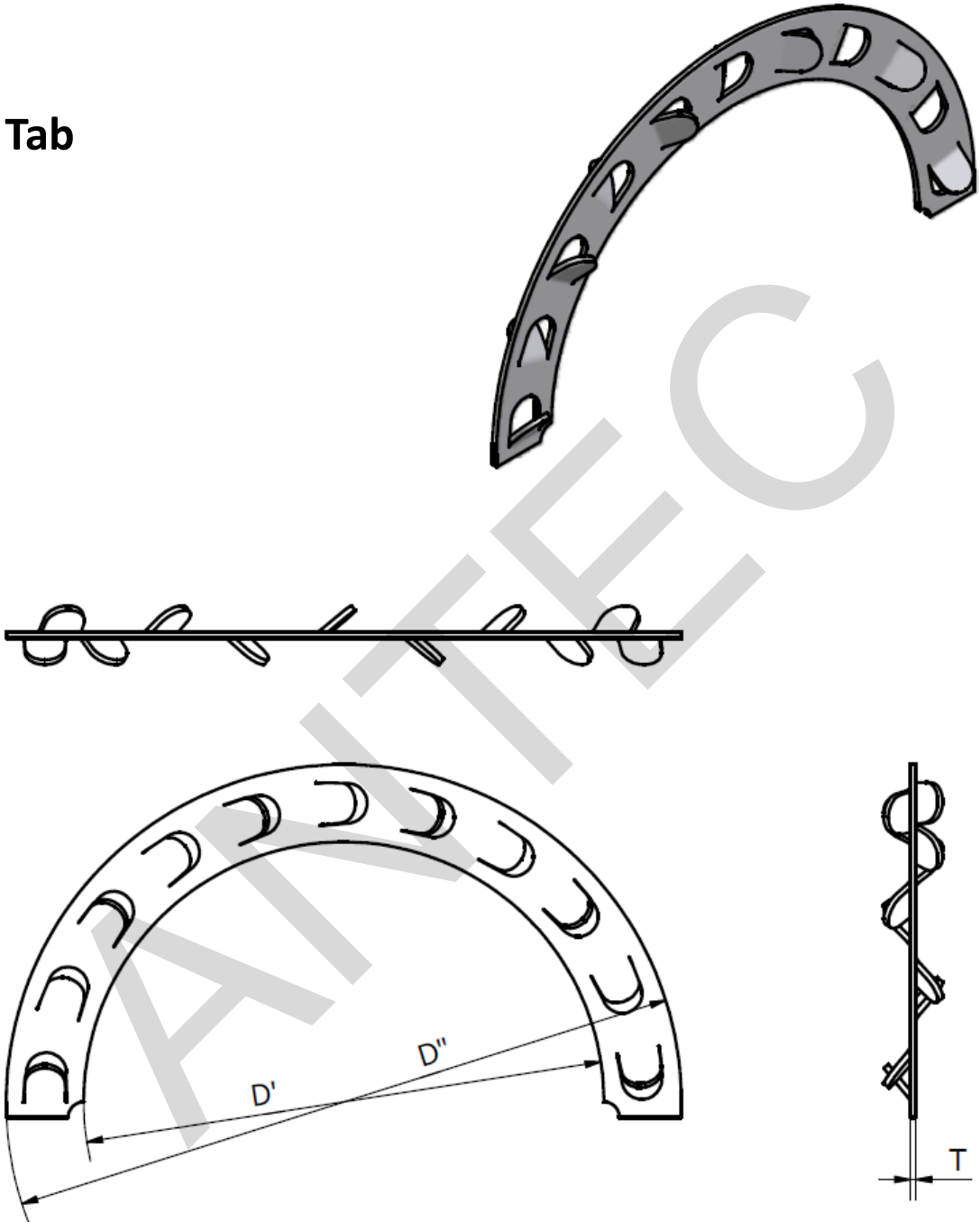

All items can be manufactured in various alloy steels.

Shape, spacing, size, diameter and orientation of tabs to be specified by customer.

Tolerances:

+/- 3mm on Dimensional

+/- 3° on Angular Dimensions

Unless otherwise noted.

Tabs as drawn are diagrammatic only.

This drawing is the property of Antec Group Pty Ltd and is supplied on the understanding it is not to be used for any purpose, copied or communicated to any other person without written permission of the proprietor. All rights are reserved for product design concept. Antec products are guaranteed to conform within normal commercial tolerance of the applicable description furnished and to be manufactured from material as specified. No other guarantees or warranty, including warranty for fitness of products for in service operating condition shall exist in connection with sale of Antec products. Heat treatment after manufacture is not included unless specified.

Hex Mesh & Punch Tabs

CB 1

C Bar 25mm C - BAR (STANDARD TYPE)

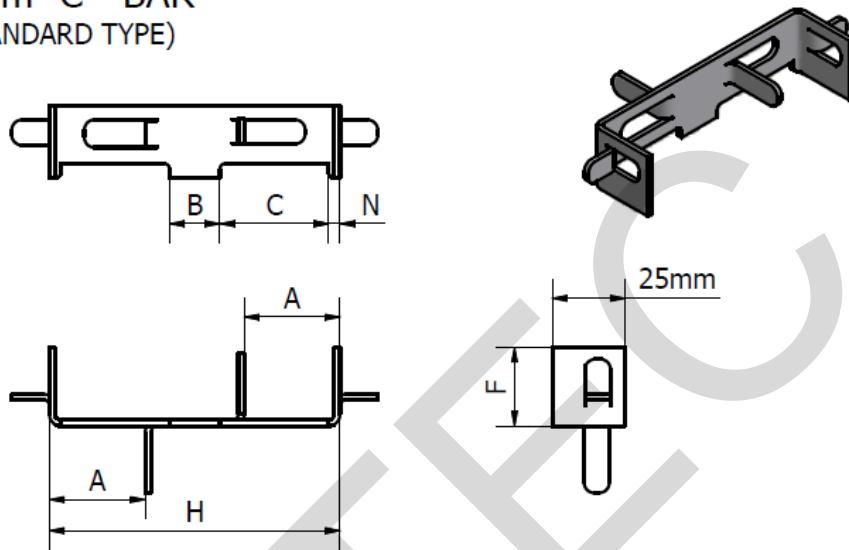

19mm C - BAR (LOWER TYPE)

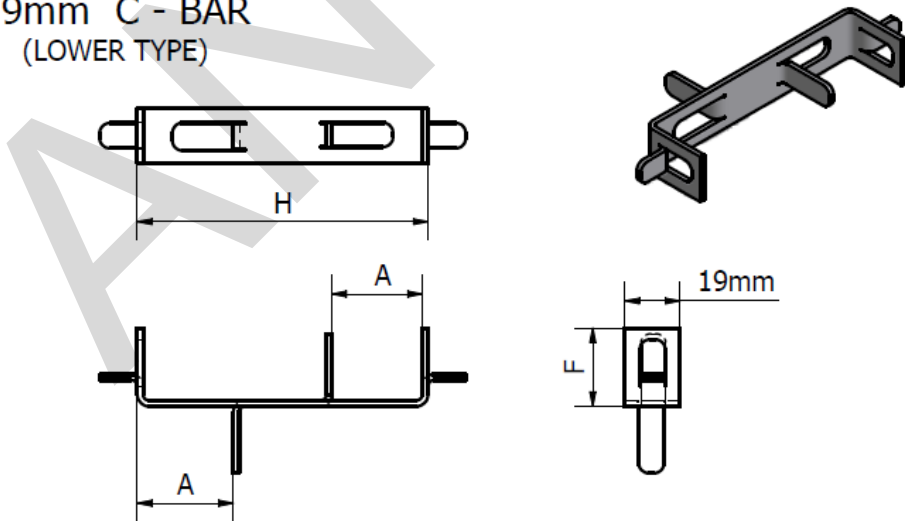

All items can be manufactured in various alloy steels.

Tolerances:

+/- 3mm on Dimensional

+/- 3° on Angular Dimensions

Unless otherwise noted.

This drawing is the property of Antec Group Pty Ltd and is supplied on the understanding it is not to be used for any purpose, copied or communicated to any other person without written permission of the proprietor. All rights are reserved for product design concept. Antec products are guaranteed to conform within normal commercial tolerance of the applicable description furnished and to be manufactured from material as specified. No other guarantees or warranty, including warranty for fitness of products for in service operating condition shall exist in connection with sale of Antec products. Heat treatment after manufacture is not included unless specified.

Hex Mesh & Punch Tabs

SH 1

Single Hex Anchor

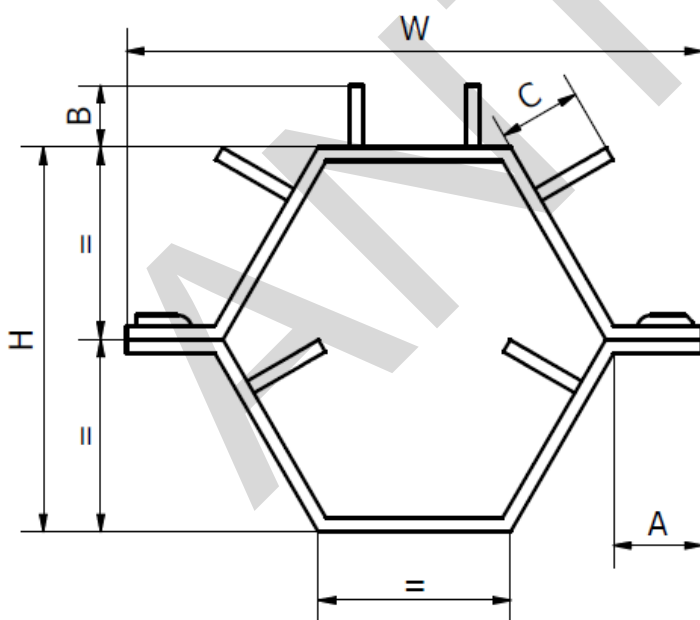
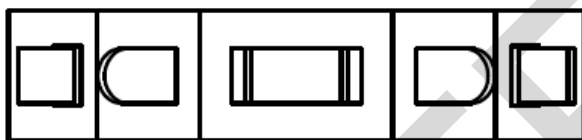
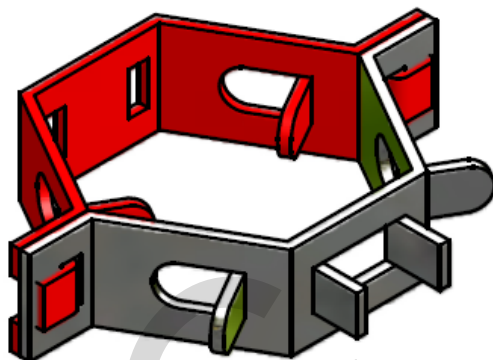

All items can be manufactured in various alloy steels.

Tolerances:

+/- 3mm on Dimensional

+/- 3° on Angular Dimensions

Unless otherwise noted.

Standard sizes for X are 19 and 25 mm.

This drawing is the property of Antec Group Pty Ltd and is supplied on the understanding it is not to be used for any purpose, copied or communicated to any other person without written permission of the proprietor. All rights are reserved for product design concept. Antec products are guaranteed to conform within normal commercial tolerance of the applicable description furnished and to be manufactured from material as specified. No other guarantees or warranty, including warranty for fitness of products for in service operating condition shall exist in connection with sale of Antec products. Heat treatment after manufacture is not included unless specified.

Hex Mesh & Punch Tabs

SH 2

Single Hex Spacing Details

Spacing Pattern 1 – The typical layout shown is for general applications and where the refractory can be installed downhand. In severe service conditions or applications where refractory cannot be installed downhand, a closer spacing should be considered. Layout as shown below requires approximately 115 cells per m².

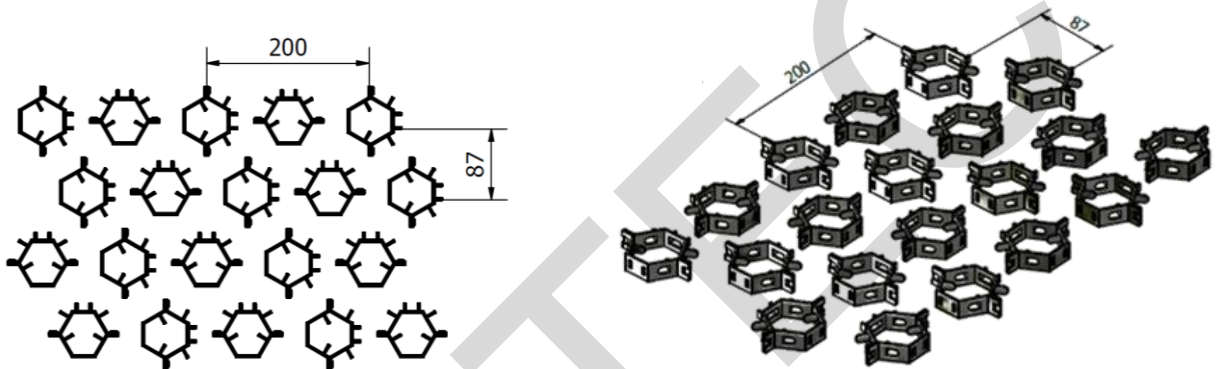

Spacing Pattern 2 – Alternative spacing used for more severe service conditions or where additional retention is preferred during refractory installation (such as a non downhand application). Layout as shown below requires approximately 145 cells per m².

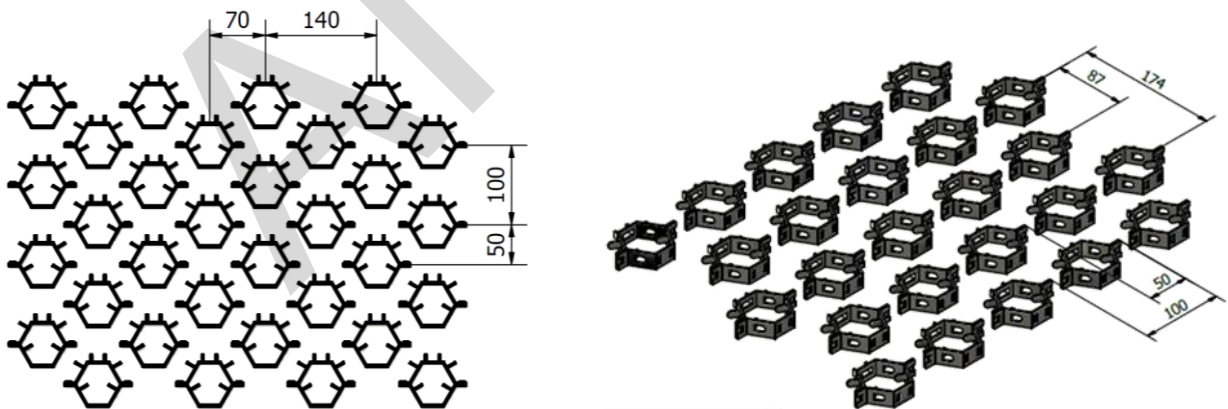

All items can be manufactured in various alloy steels.

Tolerances:

+/- 3mm on Dimensional

+/- 3° on Angular Dimensions

Unless otherwise noted.

This drawing is the property of Antec Group Pty Ltd and is supplied on the understanding it is not to be used for any purpose, copied or communicated to any other person without written permission of the proprietor. All rights are reserved for product design concept. Antec products are guaranteed to conform within normal commercial tolerance of the applicable description furnished and to be manufactured from material as specified. No other guarantees or warranty, including warranty for fitness of products for in service operating condition shall exist in connection with sale of Antec products. Heat treatment after manufacture is not included unless specified.

Hex Mesh & Punch Tabs

SH 3

Half Hex Anchor

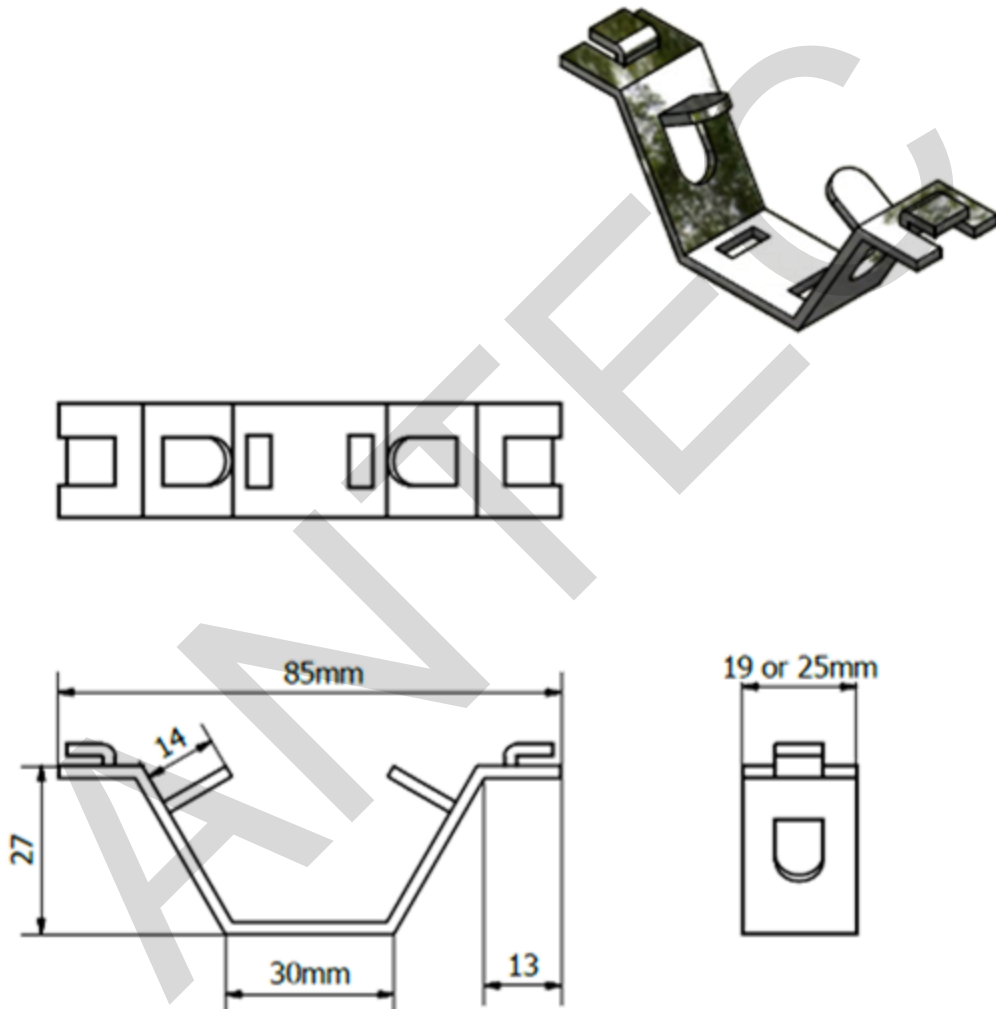

All items can be manufactured in various alloy steels.

Tolerances:

+/- 3mm on Dimensional

+/- 3° on Angular Dimensions

Unless otherwise noted.

This drawing is the property of Antec Group Pty Ltd and is supplied on the understanding it is not to be used for any purpose, copied or communicated to any other person without written permission of the proprietor. All rights are reserved for product design concept. Antec products are guaranteed to conform within normal commercial tolerance of the applicable description furnished and to be manufactured from material as specified. No other guarantees or warranty, including warranty for fitness of products for in service operating condition shall exist in connection with sale of Antec products. Heat treatment after manufacture is not included unless specified.

Stainless Steel Fibres

Fibrex HT Stainless Steel Fibres reinforce monolithic refractory against thermal and mechanical shock by reducing cracking and spalling susceptibility. Fibrex HT is a new proprietary product research and developed by Fibre Technology as an enhanced alternative to 446 and 430 steel fibres.



Fibrex HT performs best in refractory operating in the following conditions:

- Thermal cycling to 1600°C*
- Continuous soaking to 1200°C
- Moderate-High mechanical shock
- Oxidising, Sulphur, Reducing, Hydrogen Atmospheres

* Dependant on the insulation properties of the refractory

Fibrex HT Plus can be used in refractory operating conditions of:

- Moderate thermal cycling
- Continuous fibre soaking temperature up to 1100°C
- Moderate mechanical shock
- High temperature corrosive atmospheres (sulphidation, chlorination etc)

Fibrex HT – Stainless Steel Fibres

These fibres can be used in refractory operating conditions of:

- Thermal cycling to 1600°C (dependent on the insulation properties of the refractory)
- Continuous soaking to 1200°C
- Moderate - High mechanical shock
- Oxidising, Sulphur, Reducing, Hydrogen Atmospheres

Chemical Composition (maximum unless stated):

C	Si	Mn	P	S	Cr	Ni	Others	Fe
0.20	3.5	2.0	0.050	0.03	17.0-21.0	0.5	2.0-6.0	balance

Melting Temperature: 1425-1510°C

Critical Oxidation Temperature:

Cyclic Heating (in a refractory):	1600°C
Continuous Service (in a refractory):	1200°C
Cyclic Heating	1100°C

Tensile Strength:

20°C	740 MPa
870°C	63 Mpa

Modulus of Elasticity (870°C): 90-100 Gpa

Coefficient of Thermal Expansion (870°C): 12.1 @ 10⁻⁶ / °C

Thermal Conductivity (540°C): 24.6 W/m²K

ME Fibre – Typical Dimensions & Aspect Ratios

Fibre Length ¹	Typical Equivalent Dia ²	Typical Aspect Ratio ³	Typical No / kg
6mm	0.18mm	33	839,000
12mm	0.34mm	35	118,000
20mm	0.47mm	43	37,000
25mm	0.50mm	50	26,000
35mm	0.64mm	56	12,000
50mm	0.83mm	60	5,000

1. Other fibre lengths can be manufactured on request
2. Other fibre diameters can be manufactured on request
3. Aspect ratio is calculated as fibre length + diameter

Fibre HT Plus – Stainless Steel Fibres

These fibres can be used in refractory operating conditions of:

- Moderate thermal cycling
- Continuous fibre soaking temperature up to 1100°C in the refractory
- Moderate mechanical shock
- High temperature corrosive atmospheres (sulphidation, chlorination etc)

Chemical Composition (maximum unless stated):							
C	Si	Mn	P	S	Cr	Ni	Others
0.50	3.5	2.0	0.050	0.10	16.0-20.0	4.0-6.0	-
Melting Temperature:						1400-1455°C	
Critical Oxidation Temperature:							
Cyclic Heating:						870°C	
Continuous Service:						1100°C	
Tensile Strength:							
20°C						515MPa	
870°C						124MPa	
Modulus of Elasticity (870°C):						124GPa	
Coefficient of Thermal Expansion (870°C):						20.2 @ 10 ⁻⁶ / °C	
Thermal Conductivity (540°C):						21.5 W/m ² K	

ME Fibre – Typical Dimensions & Aspect Ratios

Fibre Length ¹	Typical Equivalent Dia ²	Typical Aspect Ratio ³	Typical No / kg
6mm	0.18mm	33	839,000
12mm	0.34mm	35	118,000
20mm	0.47mm	43	37,000
25mm	0.50mm	50	26,000
35mm	0.64mm	56	12,000
50mm	0.83mm	60	5,000

1. Other fibre lengths can be manufactured on request
2. Other fibre diameters can be manufactured on request
3. Aspect ratio is calculated as fibre length + diameter

ME 446 – Stainless Steel Fibres

These fibres can be used in refractory operating conditions of:

- High thermal cycling or
- Continuous fibre soaking temperature up to 1100°C in refractory
- Moderate mechanical shock
- High temperature oxidation resistance

Chemical Composition (maximum unless stated):

C	Si	Mn	P	S	Cr	Ni	Others
0.40	3.5	2.0	0.050	0.10	23.0-27.0	0	-

Melting Temperature:

1425-1510°C

Critical Oxidation Temperature:

Cyclic Heating:

1205°C

Continuous Service:

1100°C

Tensile Strength:

870°C

53 MPa

Modulus of Elasticity (870°C):

97 GPa

Coefficient of Thermal Expansion (870°C):

13.1 @ 10⁻⁶ / °C

Thermal Conductivity (540°C):

24.8 W/m²K

ME Fibre – Typical Dimensions & Aspect Ratios

Fibre Length ¹	Typical Equivalent Dia ²	Typical Aspect Ratio ³	Typical No / kg
6mm	0.18mm	33	839,000
12mm	0.34mm	35	118,000
20mm	0.47mm	43	37,000
25mm	0.50mm	50	26,000
35mm	0.64mm	56	12,000
50mm	0.83mm	60	5,000

1. Other fibre lengths can be manufactured on request
2. Other fibre diameters can be manufactured on request
3. Aspect ratio is calculated as fibre length + diameter

ME 304 – Stainless Steel Fibres

These fibres can be used in refractory operating conditions of:

- Moderate thermal cycling or
- Continuous fibre soaking temperature up to 900°C in refractory
- Moderate mechanical shock
- High temperature corrosive atmospheres (sulphidation, chlorination etc)

Chemical Composition (maximum unless stated):

C	Si	Mn	P	S	Cr	Ni	Others
0.50	3.5	2.0	0.050	0.10	18.0-20.0	8-12	-

Melting Temperature: 1400-1455°C

Critical Oxidation Temperature:

Cyclic Heating: 870°C

Continuous Service: 900°C

Tensile Strength:

870°C 124MPa

Modulus of Elasticity (870°C): 124GPa

Coefficient of Thermal Expansion (870°C): 20.2 @ 10⁻⁶ / °C

Thermal Conductivity (540°C): 20.1 W/m²K

ME Fibre – Typical Dimensions & Aspect Ratios

Fibre Length ¹	Typical Equivalent Dia ²	Typical Aspect Ratio ³	Typical No / kg
6mm	0.18mm	33	839,000
12mm	0.34mm	35	118,000
20mm	0.47mm	43	37,000
25mm	0.50mm	50	26,000
35mm	0.64mm	56	12,000
50mm	0.83mm	60	5,000

1. Other fibre lengths can be manufactured on request
2. Other fibre diameters can be manufactured on request
3. Aspect ratio is calculated as fibre length + diameter

ME 310 – Stainless Steel Fibres

These fibres can be used in refractory operating conditions of:

- Moderate thermal cycling or
- Continuous fibre soaking temperature up to 1150°C in refractory
- Extreme mechanical shock
- Extreme high temperature corrosive atmospheres

Chemical Composition (maximum unless stated):

C	Si	Mn	P	S	Cr	Ni	Others
0.50	3.5	2.0	0.050	0.10	24.0-26.0	19.0-22.0	-

Melting Temperature:

1400-1455°C

Critical Oxidation Temperature:

Cyclic Heating:

1040°C

Continuous Service:

1150°C

Tensile Strength:

870°C

152MPa

Modulus of Elasticity (870°C):

125GPa

Coefficient of Thermal Expansion (870°C):

18.5 @ 10⁻⁶ / °C

Thermal Conductivity (540°C):

18 W/m²K

ME Fibre – Typical Dimensions & Aspect Ratios

Fibre Length ¹	Typical Equivalent Dia ²	Typical Aspect Ratio ³	Typical No / kg
6mm	0.18mm	33	839,000
12mm	0.34mm	35	118,000
20mm	0.47mm	43	37,000
25mm	0.50mm	50	26,000
35mm	0.64mm	56	12,000
50mm	0.83mm	60	5,000

1. Other fibre lengths can be manufactured on request
2. Other fibre diameters can be manufactured on request
3. Aspect ratio is calculated as fibre length + diameter

ME 330 – Stainless Steel Fibres

These fibres can be used in refractory operating conditions of:

- Moderate thermal cycling or
- Continuous fibre soaking temperature up to 1165°C in refractory
- Extreme mechanical shock
- Extreme high temperature corrosive atmospheres

Chemical Composition (maximum unless stated):

C	Si	Mn	P	S	Cr	Ni	Others
0.50	3.5	2.0	0.050	0.10	17.0-19.0	34.0-36.0	-

Melting Temperature: 1345-1425°C

Critical Oxidation Temperature:

Cyclic Heating: 1050°C

Continuous Service: 1165°C

Tensile Strength:

870°C 193MPa

Modulus of Elasticity (870°C): 134GPa

Coefficient of Thermal Expansion (870°C): 17.6 @ 10⁻⁶ / °C

Thermal Conductivity (540°C): 21.5 W/m²K

ME Fibre – Typical Dimensions & Aspect Ratios

Fibre Length ¹	Typical Equivalent Dia ²	Typical Aspect Ratio ³	Typical No / kg
6mm	0.18mm	33	819,000
12mm	0.34mm	35	115,000
20mm	0.47mm	43	36,000
25mm	0.50mm	50	25,500
35mm	0.64mm	56	11,000
50mm	0.83mm	60	4,500

1. Other fibre lengths can be manufactured on request

2. Other fibre diameters can be manufactured on request

3. Aspect ratio is calculated as fibre length + diameter

METALX – Stainless Steel Fibres

METALX is a proprietary stainless steel fibre with improved oxidation resistance compared to traditional stainless steels. This steel is ideally suited to extreme high temperature and corrosive environments. METALX is manufactured using Fibretech's unique Melt Overflow Rapid Solidification (RS) technology. The chemistry has been designed to produce a highly adherent oxide coating, which extends the life of the fibres.

Chemical Composition (maximum unless stated):						
C	Si	Mn	P	S	Cr	Others
0.30	3.0	2.0	0.05	0.05	23.0	Cr Vi free
Melting Temperature:						1480-1530°C
Critical Oxidation Temperature of Fibres:						
Cyclic Heating:						1250°C
Continuous Service:						1300°C
Critical Oxidation Temperature in Refractories:						
Cyclic Heating (dependent on refractory insulation properties):						1700°C
Continuous Service:						1300°C
Tensile Strength:						
20°C						>750 Mpa
870°C						>36 Mpa
Modulus of Elasticity at 20°C:						>260 Gpa
Coefficient of Thermal Expansion:						15 x 10 ⁻⁶ / °C
Thermal Conductivity:						16 W/m ² K
Specific Heat Capacity:						0.46 Kj/kgK
Density:						7.25 g/cm ³

ME Fibre – Typical Dimensions & Aspect Ratios

Fibre Length	Typical Effective Diameter	Typical No / kg
12mm	0.43mm	78,000
20mm	0.43mm	47,000
25mm	0.43mm	37,000
35mm	0.43mm	27,000

Refractory Anchor Division

9 Chicago Ave, Blacktown
NSW 2148 Australia
Ph: +61 2 9622 9622
E: antecnsw@antec.com.au
W: antecrefractory.com.au

Contact Details

For quotes, drawings and material enquiries please contact:

Garry Craig

Managing Director – Refractory
Ph: +61 3 8645 3211
M: +61 417 225 833
E: garry.craig@antec.com.au

Kate Dewick

Estimating & Technical Support
Ph: +61 2 9421 1951
E: kate.dewick@antec.com.au

Miles Simpson

General Manager – Refractory
Ph: +61 2 9421 1908
M: +61 421 180 831
E: miles.simpson@antec.com.au

David Alwin

Technical Manager
Ph: +61 2 9421 1969
E: david@antec.com.au